

3 Wheel Forklift

EK16A-138 / EK16A-177

- 3500 lbs. load capacity
- Lift height 138-177" (11.5'-14.75')
- Side Shift
- Curtis Controller
- Tilt
- Lowered Mast Height 79.9-86.6"
- Cushion Tire
- Battery 24V/320AH
- Charger Included
- AC Drive Motor



EK16A-138 & EK16A-177

Superior quality, maneuverable, compact, and durable for all your material handling applications. Ideal for small aisles and areas.

Model (Manufacturer's type designation)		EK16A-138	EK16A-177
Load Capacity/Rated Load	Q(lb)	3500	3500
Load Centre Distance	C(in)	19.7	19.7
Lift height	h3(in)	138	177
Free lift height	h2(in)	34.4	29.5
Mast/fork carriage tilt forward/backward	$\alpha/\beta(^{\circ})$	3.92/5.44	2.12/3.68
Lowered mast height	h1(in)	86.6	79.9
Overhead load guard(cab) height	h5(in)	76	76
Ground clearance, Centre of wheelbase	m1(in)	3.4	3.4
Length to face of forks	l2(in)	65	65
Overall width	b1(in)	42.1	42.1
Fork dimensions	s/e/l(in)	1.4x4.0x42.1	1.4x4.0x42.1
Fork Adjustment Range	in	7.9/26	7.9/26
Turning radius	Wa(in)	58.9	58.9
Extended mast height	h4(in)	141.7	181.1
Travel speed, laden	mph	4.2	4
Travel speed, unladen	mph	4.6	4.5
Lift speed, laden/unladen	ft/s	25.6/39.8	25.6/40.2
Drop speed, laden/unladen	ft/s	42.6/48.5	42.4/49.2
Max gradient performance, laden	%	6	6
Max gradient performance, unladen	%	10	10
Service brake		Electric Brake	Electric Brake
Track width, front	in	35.8	35.8
Wheelbase	in	49.2	49.2
Drive motor	kw	2.2	2.2
Lift motor	kw	3.3	3.3
Battery voltage, nominal capacity k5	V/Ah	24V/320	24V/320
Type of drive control		AC	AC
Manufacturer of drive control		ZAPI	ZAPI

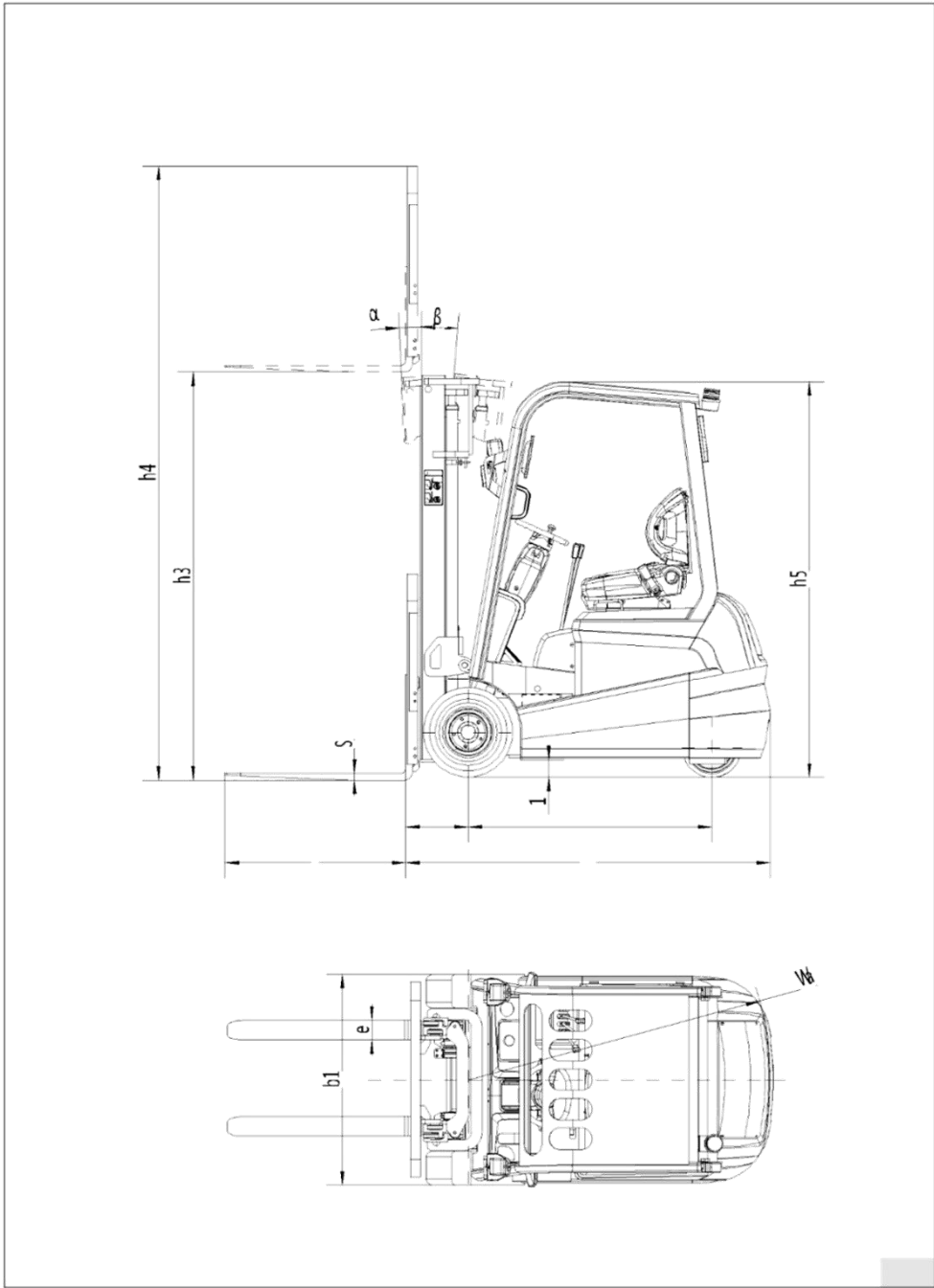

MODEL #	MAST	LIFT HEIGHT	MAX MAST HEIGHT	SERVICE WEIGHT
EK16A-138	86.6"	138"	141.7"	5020 lbs.
EK16A-177	79.9"	177"	181.1"	5200 lbs.