

Lithium Straddle Stacker

EB14C-98LI / EB14C-118LI /

EB14C-138LI / EB14C-145LI

- 3000 lbs. load capacity
- Lift height 98-145"
- Lowered Mast Height 75.2-98.8"
- Polyurethane Tires
- Batteries 24V/50Ah Lithium
- Charger Included
- DC Drive Motor
- USB charging port



Lithium Straddle Stacker



EB14C-98LI / EB14C-118LI / EB14C-138LI / EB14C-145LI

Model	EB14C-98/118/138/145LI	
Power Type	Electric	
Operating Mode	Walk-behind	
Rated Load Capacity	Q (lb.)	3000
Load Center Distance	c (in)	20
Wheelbase	y (in)	50.2
Tire Type, Drive Wheel/Load Wheel	Polyurethane Tires	
Drive Wheel Size (Diameter × Width)	in	Φ8.2x2.8
Load Wheel Size (Diameter × Width)	in	Φ3.1x2.8
Height When Mast is Retracted	h1 (in)	75.2 / 85.0 / 94.2 / 98.8
Lift Height	h3 (in)	98 / 118 / 138 / 145
Maximum Height When Mast is Extended	h4 (in)	127.6 / 146.5 / 166.9 / 174.8
Minimum Fork Height	h13 (in)	2.6
Overall Length	l1 (in)	71.3
Inner Width of Legs	in	35.4 / 39.4 / 43.3 / 47.2 / 51.2
Fork Dimensions	s/e/l	1.4 × 4.0 × 45.3
Fork Adjustment Range (Fork Outer Width)	b5 (in)	8.7 – 32.1
Minimum Ground Clearance at Wheelbase Center	m2(in)	1.2
Minimum Turning Radius	Wa (in)	57.5
Travel Speed, Laden/Unladen	mph	2.5/2.5
Lift Speed, Laden/Unladen	in/s	3.7/5.1
Climbing Speed, Laden/Unladen	%	5/10
Service Brake	Electromagnetic	
Drive Motor Power	kw	0.75
Lift Motor Power	kw	2.2
Battery Voltage/Rated Capacity	(V)/(Ah)	Lithium Battery 24/50
Charger Voltage	(V)/(A)	Lithium Battery 24/20
Type of Drive Control	DC	
Steering Type	Mechanical	

Lithium Straddle Stacker



EB14C-98LI / EB14C-118LI / EB14C-138LI / EB14C-145LI

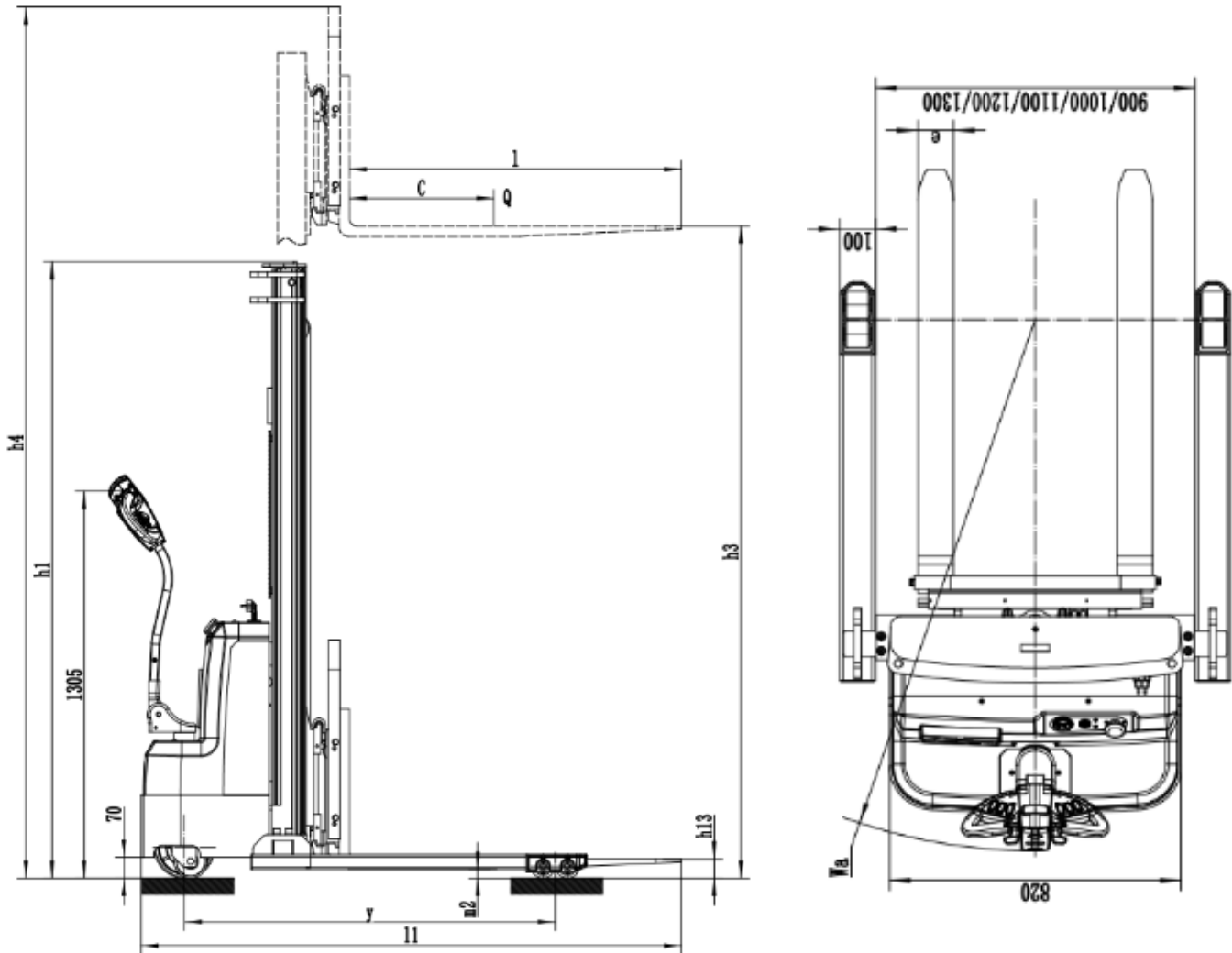

MODEL #	MAST	LIFT HEIGHT	MAX MAST HEIGHT	SERVICE WEIGHT
EB14C-98LI	75.2"	98"	127.6"	1410 Lbs.
EB14C-118LI	85"	118"	146.5"	1430 Lbs.
EB14C-138LI	94.2"	138"	166.9"	1470 Lbs.
EB14C-145LI	98.8"	145"	174.8"	1800 Lbs.



1761 W. Holt Ave.

Pomona, CA 91768 USA

AUTHORIZED DEALERS ONLY

www.ekkolifts.com

T: (877) 232-6517 F: (909) 222-6861