

- 3000 lbs. load capacity
- Lift height 118-145"
- Lowered Mast Height 81.7-95.5"
- Polyurethane Tires
- Batteries 24V/50Ah Lithium
- Charger Included
- DC Drive Motor
- Side Shift
- USB charging port



# Lithium Straddle Stacker

EB14CS-118LI / EB14CS-138LI / EB14CS-145LI



Manufacture	EKKO	
Model	EB14CS-118/138/145LI	
Power Type	Electric	
Operating Mode	Walk-behind	
Rated Load Capacity	Q (lbs.)	3000
Load Center Distance	c (in)	20
Wheelbase	y (in)	50.6
Tire Type, Drive Wheel/Load Wheel	Polyurethane Tires	
Drive Wheel Size (Diameter × Width)	in	Φ8.3x2.8
Load Wheel Size (Diameter × Width)	in	Φ3.1x2.8
Height When Mast is Retracted	h1 (in)	81.7 / 91.5 / 95.5
Lift Height	h3 (in)	118 / 138 / 145
Maximum Height When Mast is Extended	h4 (in)	147.6 / 166.9 / 174.8
Minimum Fork Height	h13 (in)	2.6
Overall Length	l1 (in)	73.7
Inner Width of Legs	in	35.4 / 39.4 / 43.3 / 47.2 / 51.2
Fork Dimensions	s/e/l	1.4 × 4.0 × 45.3
Fork Adjustment Range (Fork Outer Width)	b5 (in)	8.7 - 32.1
Minimum Ground Clearance at Wheelbase Center	m2(in)	1.2
Minimum Turning Radius	Wa(in)	60.8
Travel Speed, Laden/Unladen	mph	2.5 / 2.5
Lift Speed, Laden/Unladen	in/s	3.9 / 4.9
Climbing Speed, Laden/Unladen	%	5/10
Service Brake	Electromagnetic	
Drive Motor Power	kw	0.75
Lift Motor Power	kw	2.2
Battery Voltage/Rated Capacity	(V)/(Ah)	24/50 Lithium
Charger Voltage	(V)/(A)	24/20
Type of Drive Control	DC	
Steering Type	Mechanical	
Noise Level at Operator's Ear	dB(A)	<70

# Lithium Straddle Stacker

EB14CS-118LI / EB14CS-138LI / EB14CS-145LI

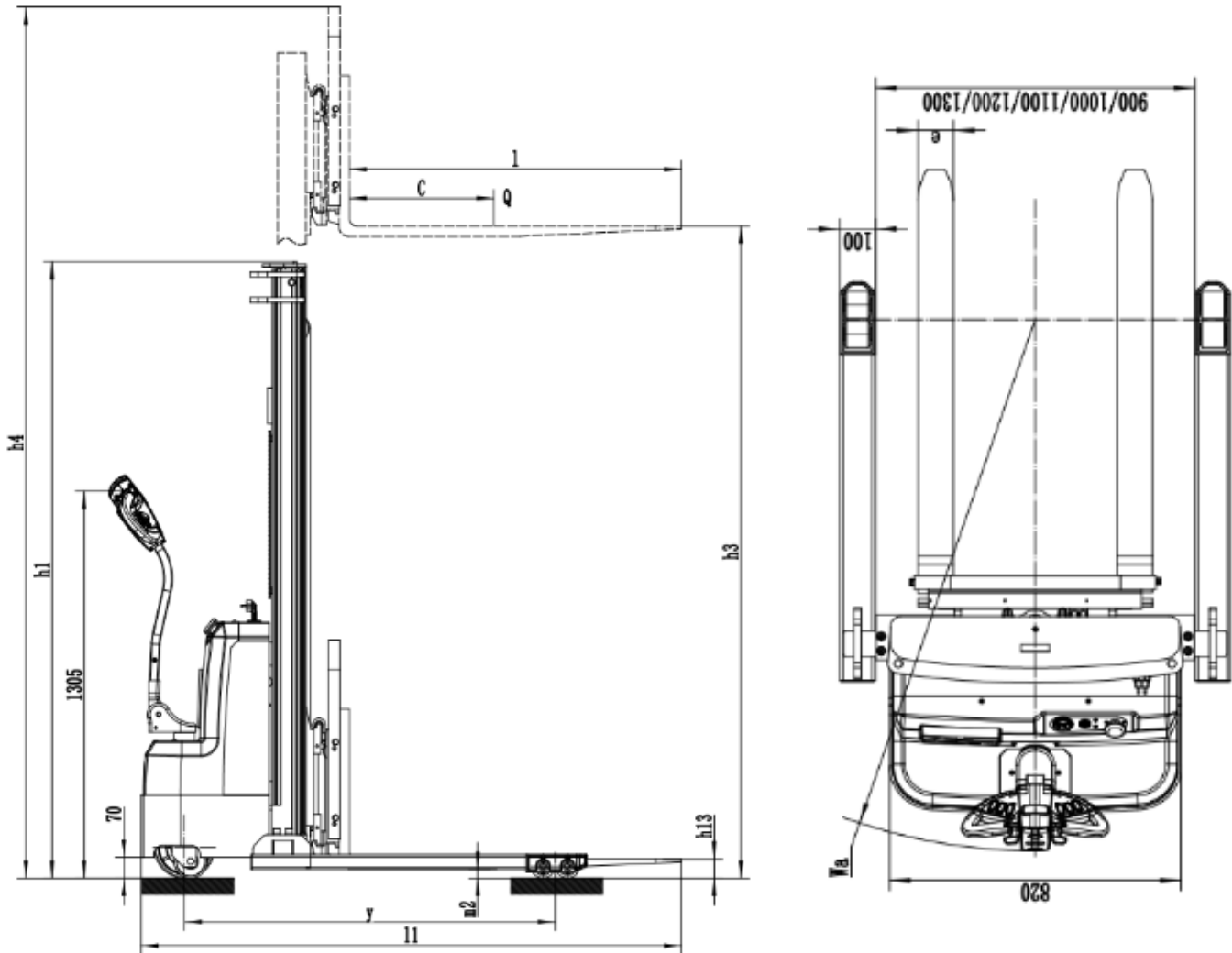

MODEL #	MAST	LIFT HEIGHT	MAX MAST HEIGHT	SERVICE WEIGHT
EB14CS-118LI	81.7"	118"	147.6"	1520 Lbs.
EB14CS-138LI	91.5"	138"	166.9"	1780 Lbs.
EB14CS-145LI	95.5"	145"	174.8"	1800 Lbs.



1761 W. Holt Ave.

Pomona, CA 91768 USA

AUTHORIZED DEALERS ONLY

[www.ekkolifts.com](http://www.ekkolifts.com)

T: (877) 232-6517 F: (909) 222-6861