

EKKO[®]

MATERIAL HANDLING EQUIPMENT

MOVING AHEAD

SPECIFICATION

ORDER PICKER

EOP68

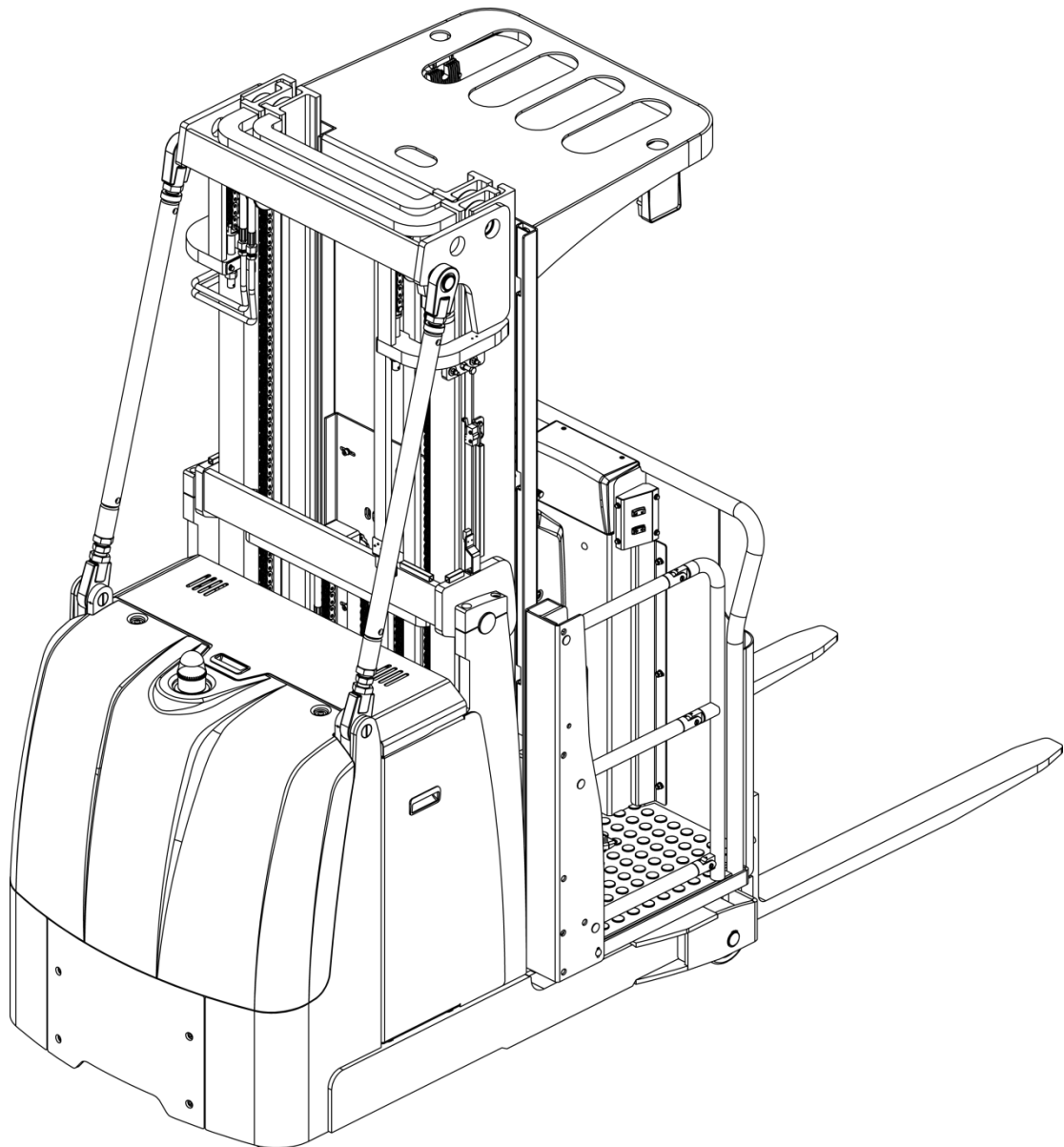

Introduction

In order to meet the needs of the national environmental protection request, To reduce industrial pollution and improve productivity, we develop new series of EOP68 Type High level order picker . on the basis of absorption of the advantages of domestic & overseas battery order picker, they are especially suitable for cargo loading and unloading, handling, stacking, etc. for food, bank, light textile, station, port, logistics and other enterprises.

The order picker adopts advanced structures such as EPS steering system, new AC controller. It is equipped with high-quality motor, traction battery and high-power pumping station motor. Therefore, it has the characteristics of superior performance, convenient operation, wide field of view, flexible steering, reliable braking, good power, low noise, no pollution, and beautiful appearance.

This manual describes the technical parameters of the order picker, working principle and operation, maintenance, and other aspects. It can help operators use the order picker more reasonable, make its maximum effect.

It is hoped that Operator strictly abide the regulations and the precautions in this manual when using the order picker .Carefully use them so that your order picker can be in the best working condition for long period of time to maximize its effectiveness. And create better economic benefits.

The Statement

Our company production model EOP68 type high level order picker is a special motor vehicle used in factory ,tourist attractions ,amusement places which is specified by “special equipment safety supervision regulations” .

Contents

1.The General Introduction.....	1
2.Proper usage.....	2
3.Introduction of the product.....	3
3.1Overview of main components	3
3.2Truck schematic diagram & Model parameters	4
3.3Safe operation and warning labels	7
3.4Name plate	8
4.Safety Caution.....	8
5.Test run,Transportation,Outage.....	10
5.1Test run	10
5.2Lifting & Transportation.....	10
5.3Outage.....	11
6.Routine Inspection	11
7.The Schematic diagram of Operating Mechanism	11
8Operating specification.....	14
8.1Parking	14
8.2Loading capacity graph	14
8.3Lifting up/Lowering down	15
8.4Traveling.....	16
8.5Steering	17
8.6Monitor	18
8.7Braking.....	19
8.8Brake structure &Brake Schematic	20
8.9Trouble	20
8.10Emergency situations.....	20
9Changing and Replacement for battery.....	21
9.1Replacement	22
9.2Charging	23
10.Maintain Introduction	23

10.1 Maintenance list.....	24
10.2 Lubrication point.....	25
10.3 Check and refill hydraulic oil.....	25
10.4 Check the electrical fuse.....	26
10.5 Remove and reinstall the shield.....	26
11. Trouble shooting	27
12. After-sales service	28
13. Electrical Schematic diagram	29
14. Hydraulic Schematic diagram	30

1.The **General** Introduction

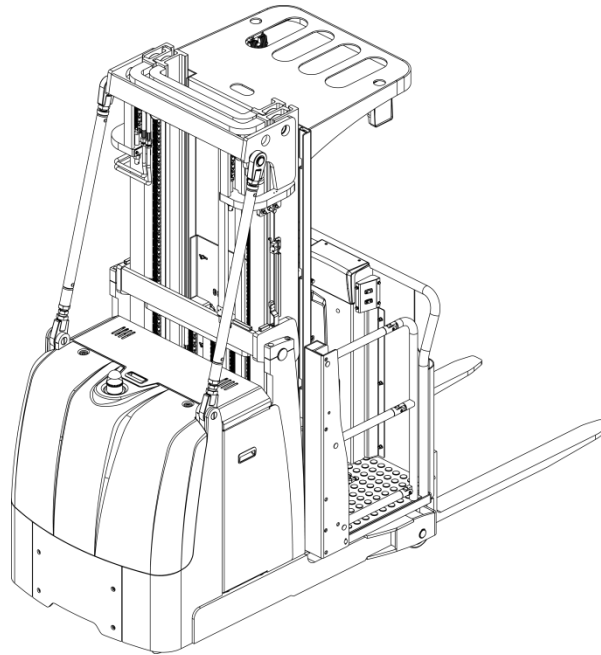

EOP68 Type High level order picker uses a battery as the power source and AC motor as power to drive the truck through gear transmission, The lifting of the fork is driven by the AC motor hydraulic drive to push the cylinder to lift and lower the cargo. As the truck Electric motor for Lifting and Driving .Then it has the characteristics of labor saving, high efficiency, stable cargo operation, simple operation, safety and reliability, low noise and no pollution.

The device is suitable for Stacking & Handling cargo on firm ,flat floors

The service environment:

- a. Altitude does not exceed 3937ft;
- b. Indoor room temperature at +5°C to +40°C ;
- c. When environment temperature at +40°C,the relative humidity can't over 50%,at low temperature ,allow bigger relative humidity
- d. Firm, Flat ground .
- e. It is forbidden to use this car in corrosive environment such as flammable and explosive or acid base

2. Proper use

Please using the High-level order picker according to this specification.

This is a stand on type High level order picker with autonomous control , lifting and lowering is controlled by the handle button.

Improper use can cause personal injury or machine damage. Operators or operating companies need to ensure proper using,

The Truck needs to be used on a firm ,flat ,intact surface and suitable surface ;the truck is designed for indoor use at room temperature from +5°C to +40°C

Use under light load without using permanent barriers or pits ,It is forbidden to operate on the slopes .During Operation ,The goods must be placed approximately at the center of the truck's load center

Lifting or Carrying people is strictly prohibited ,If carried goods .The goods must fall on the lifting point .

It is prohibited to use this truck on lifting or loading ramps.

The rated capacity is marked on the capacity label or nameplate. And the operator must pay attention to the warning signs and safety instructions.

Operating lighting must be at least 50LUX

Modification

Any modification that may affect the truck rated capacity, stability or safety operations must be approved in advance by the Truck's original manufacturer or Its authorized Manufacturer or its successor. This includes the effects of changes such as Braking ,steering ,visibility, and the addition of removable accessories.

After the manufacturer or its successor approves the modification or change ,the capacity name plate ,Label, identification marks, operation and maintenance manual must be changed accordingly

Truck damage caused by not following Instruction will lose its warranty.

3.Introduce of the product

3.1Overview of main components

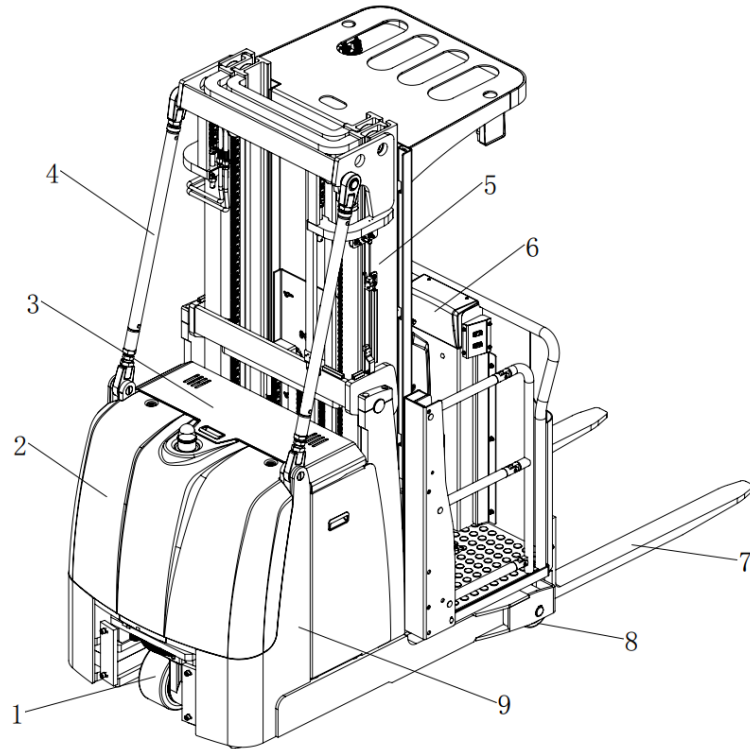

Figure 1 main components

Figure 1 main components

1.Driving wheel	2.Cover	3.Battery cover
4.Lifting reinforcement rod	5.Door frame	6.Cockpit
7.Fork	8.Bearing wheel	9.Main frame

Table 2 EOP68 high level order picker Parameter.

Table 2 EOP68 high level order picker Parameter.				
	1.2	Model		EOP68
	1.3	Drive type		Electric
	1.4	Type of operation		Stand on
	1.5	Rated load capacity	Q (lbs)	2200
	1.6	Load center	c (Inch)	19.68
	1.8	Axle center to fork face	x (Inch)	7.56
	1.9	Wheelbase	y (Inch)	53.46
weight	2.1	Service weight with battery	lbs	6270
Wheel	3.1	Tire material		PU
	3.2	Driving wheel size	$\Phi \times w$ (Inch)	$\Phi 9.84 \times 5$
	3.3	Bearing wheel size	$\Phi \times w$ (Inch)	$\Phi 5.9 \times 3.23$
	3.4	Balance wheel size	$\Phi \times w$ (Inch)	-
	3.5	No of Driving wheel, Balance		1x, /2
	3.6	Track width	b ₁₀ (Inch)	-
	3.7	Track width	b ₁₁ (Inch)	37.8
size	4.2	Lowered mast height	h ₁ (Inch)	93.11
	4.4	Lifting height	h ₃ (Inch)	177.16
	4.5	Extended mast height	h ₄ (Inch)	266.65
	4.7	Height of overhead guard(cabin)	h ₆ (Inch)	89.48
	4.8	height of seat/stand-on platform	h ₇ (Inch)	10.67
	4.11	Additional lift height	h ₉ (Inch)	30.71
	4.12	total lift height (h ₃ +h ₉)	h ₁₀ (Inch)	208.66
	4.14	Platform lifting height	h ₁₂ (Inch)	187.83
	4.15	Lowered fork height	h ₁₃ (Inch)	1.97
	4.16	Picking height (h ₁₂ +1300)	h ₁₅ (Inch)	239.01
	4.19	Overall length	l ₁ (Inch)	111.41
	4.20	Body Length	l ₂ (Inch)	69.29
	4.21	Overall width	b ₁ / b ₂ (Inch)	39.37/45.28
	4.22	Fork Size	s/e/l(Inch)	1.57/3.93/42.
	4.25	outside fork width	b ₅ (Inch)	34.33
	4.32	Min. Ground clearance	m ₂ (Inch)	1.97
	4.33	Aisle width for pallets 1000*1200	Ast (Inch)	122.24
4.34	Aisle width with pallet 800 x 1200 along	Ast (Inch)	126.77	

	4.35	Min. Turning radius	Wa (Inch)	61.81
Performance	5.1	Travel speed, laden/unladen	(km/h)	6.0/5.8
	5.2	Lifting speed, with/without load(cabin)	(mm/s)	140/150
	5.2	Lifting speed, with/without load(Fork)	(mm/s)	130/140
	5.3	Lowering speed, with/without	(mm/s)	240/250
	5.3	Lowering speed, with/without	(mm/s)	130/95
	5.8	Maximum climbing ability, with/without	(%)	3/6
	5.10	Brake Type		Electromagnet
Motor	6.1	Drive Motor	(kW)	3.0
	6.2	Lift Motor	(kW)	5.5
	6.3	Battery according to DIN 43531/35/36		no
	6.4	Battery voltage/rated capacity	(V/Ah)	24/280
	6.5	Battery weight ($\pm 5\%$)	(lbs)	600
Other	8.1	Type of drive control		AC
	8.4	Noise level at operator's ear	(dB(A))	≤ 75

3.3 Safe operation and warning labels

- 1.Name plate
- 2.Load capacity chart
- 3.Read the manual label
- 4.Wear safety rope sticker
- 5.No hitchhiking
- 6.It is forbidden to lean out of the car
- 7.Hook sticker
8. It is forbidden to stand on /off the fork
- 9.Do not put hands in the car
- 10.Watch your hands
- 11.warning label
- 12.Be careful with electricity
- 13.Emergency discharge

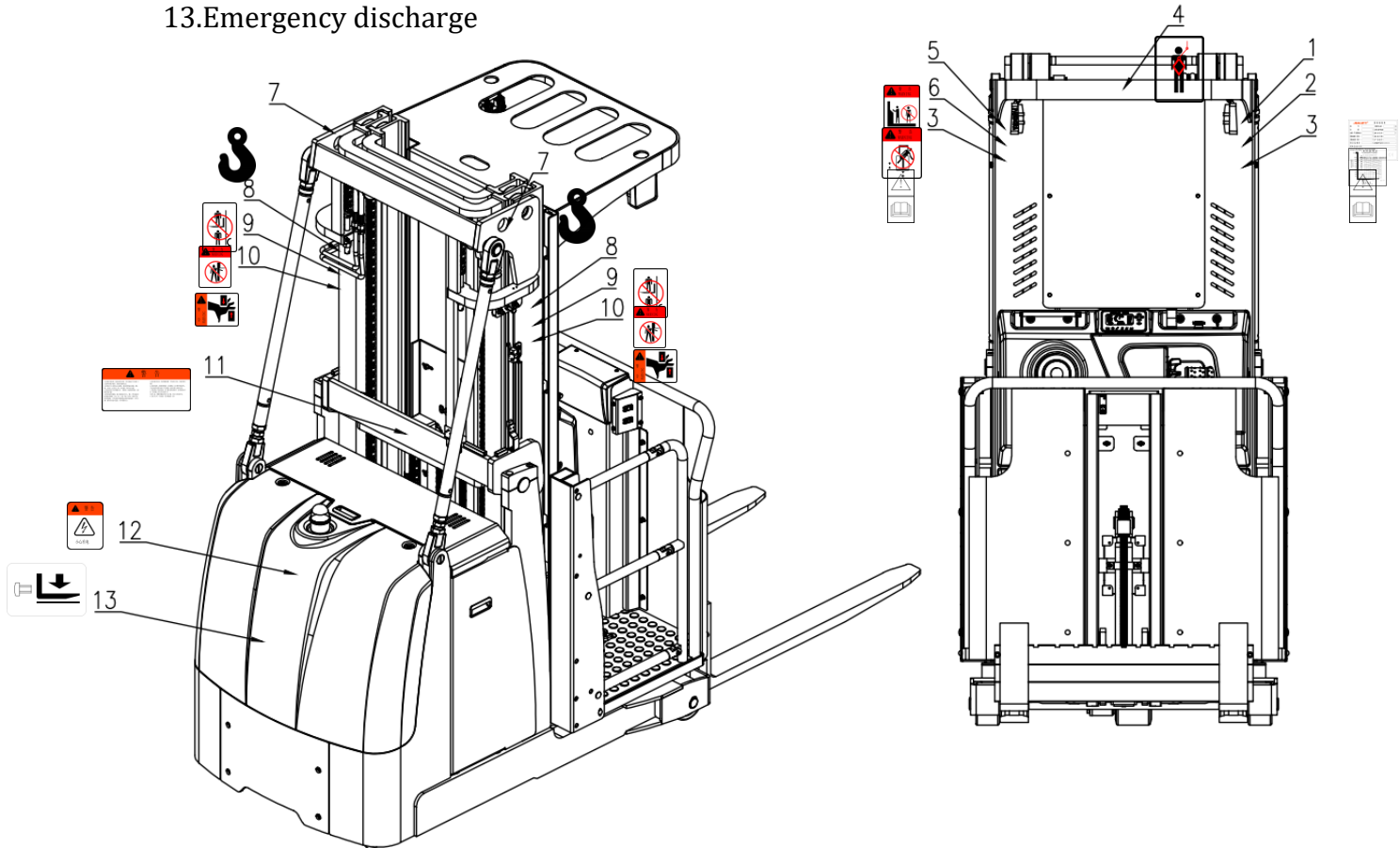

Figure 3 label diagram

3.4 Nameplate



Figure 4 Nameplate

4. Safety Caution



Please don't

- When travel outdoor, The stacking operation makes the lifting height of the cargo higher than the lifting point
- Place the foot or hand under or into the lifting mechanism
- Allow Non-Operators to stand in front of or behind the truck during moving or lifting / lowering
- Overload
- Put your foot on the front of the wheel may cause injury
- Stick your body out of the cockpit during lifting
- Push and pull cargo
- Use the car on the slope
- Use the car without Shielding panel
- Side load or tail load ,The cargo must be evenly distributed on the fork
- Use this car to load unstable ,unbalanced cargo

- **Use this car without the manufacturer's written consent**

Observing different ground condition during driving .The cargo may fall down, or the car may lose control ,Please check the loading situation frequently, If the cargo becomes unstable .Stop the operation of the truck immediately . When the cargo slide or slide off the truck, Stop the car by pressing emergency stop switch .Please refer to Chapter 6 for any truck Trouble .Maintain according to regular inspection. The forklift is not waterproof, Please use it in dry environment. Continuous operation for a long time may damage the power box ,please stop operating when Hydraulic oil temperature is too high .



- **The operator should put on safety shoes when operating the forklift**
- **The car is suitable for indoor use in temperature from +5° C to 40° C**
- **Operating lighting must be at least 50LUX**
- **Don' t use the car on the slope**
- **The uplifted cargo will become unstable because of wind .Don't lift the cargo in windy condition**
- **In order to prevent sudden movement of the car when the car is not operated (such as caused by others),turn off the car power and remove the key when not operating**

5. Test run, Transportation, Outage

5.1 Test run

Table 3 test data

Model	EOP68
Packing weight (lbs)	6270
Lifting height (Inch)	177.16
Size (Inch)	113*49.21*98.43

After receiving our new forklift or when it needs to be retest please with process with following steps before (the first)operation of the forklift :

- Check if all parts are included .and there is no damage
- Battery installation and charging (refer to Chapter 9)
- Carry out daily inspection and machine function inspection

5.2 Lifting & Transportation

Remove the cargo during transportation ,Lowered the fork to the lowest position and according to Figure 5 Safety fixed the car with special lifting equipment

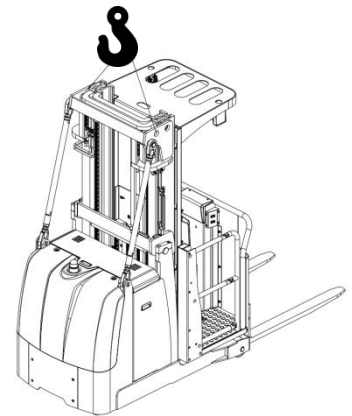

Fig 5 Lifting Point

Lifting



Use Special Crane and lifting equipment

Don't stand under shaking cargo

Don't enter the dangerous area when rising

Parking the truck safely, and and fasten the car body

Lifting the truck to the destination ,Before Moving lifting equipment please safety Fixed the car ,

The rope point can referred to figure 5

Transportation

The Truck should be firmly fixed on the truck during transportation

Lowered fork and parking the truck safety

As figure 6 shows Use the special binding belt to

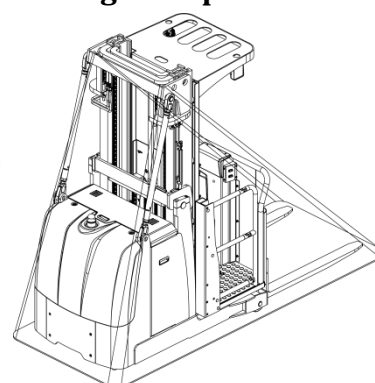

fix the tow big ribs of the car .And fixed other side on the carrier

Fig6 Fixed Point

5.3 Outage

When Storage remove the cargo and lowered the fork to lowest position. Grease all lubrication points mentioned in this manual (check regularly) to prevent rust and dust. Remove the battery and check the truck to ensure no extrusion during storage.

When the car finally out of service ,send the car to designated recycling company .According to regulations , Oil, Batteries and electronic components must be recycled .

6. Routine Inspection

This Chapter Describes check the car before using



Routine inspection can effectively find out the defect or error of this car, The following points should be checked before operation.

Remove the cargo ,Lowered the fork. Please don't use the car if there is any Problem.

- Check for scratches ,Deformation .or Cracks
- Check if the cylinder leaks of oil
- check running condition of the car
- Check if the chain or roller damage or corrosion
- Check if the wheels can move smoothly
- Press the emergency stop button to check the emergency brake function
- Check the Buzzer
- Check whether the display is displayed normally
- Check that all bolts and nuts are tightened
- Check the function of Key switch
- Check the speed limit switch

- Visually Check for any damaged tube or wires
- If the car with Protective barrier .Check for damage and correct installation.

7.The Schematic diagram of Operating Mechanism

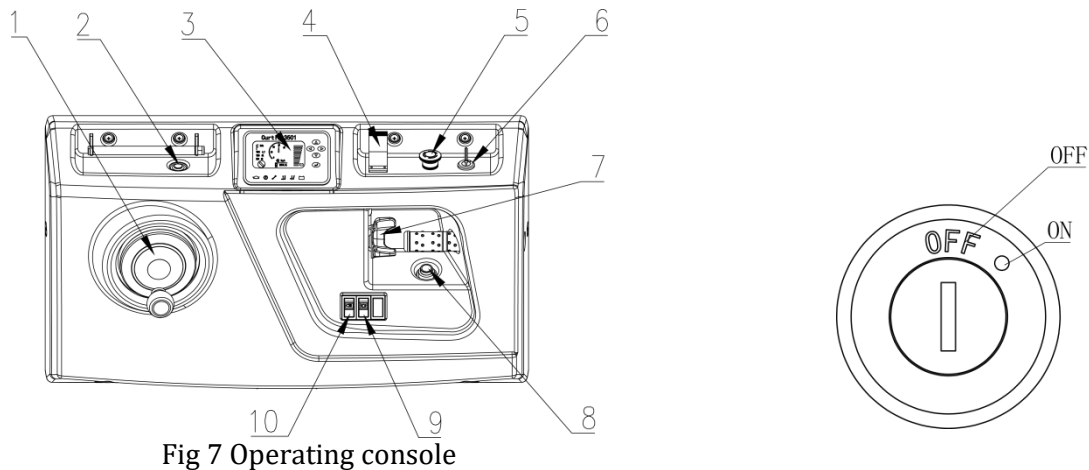

Fig 7 Operating console

Figure 7.1 the steering wheel, which controls the steering of the truck by rotating the steering wheel.

Figure 7.2 is emergency lowering button, When 7.4(as figure shows) lifting & lowering joystick fails, Press the emergency lowering button to safety lower the cockpit to the bottom

Figure 7.3 is Curtis instrument, displaying vehicle information.

Figure 7.4 is lifting & lowering joystick , which is used to control the lifting and lowering of the mast and the cockpit.

Figure 7.5 is Emergency stop switch

Figure 7.6 is Key switch ,Control truck power connection and disconnection

Figure 7.7 Accelerator , Used to control the forward and backward of the truck, and control the driving speed by controlling the degree of rotation

Figure 7.8,Horn button

Figure 7.9 Headlight switch

Figure 7.10 Warning light switch

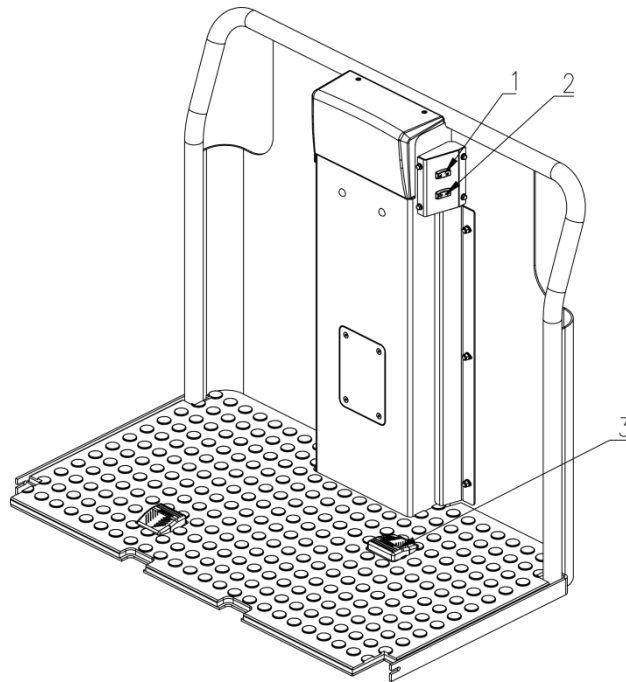

Fig 9 Operation switch

Figure 9.1 shows the lifting & lowering switch, used to control the lifting and lowering of the fork.

Figure 9.2 shows the forward and backward buttons, which are used to fine-tune the position of the truck so that the truck can pick up goods in a suitable position.

Figure 9.3 shows the foot switch. The lifting, lowering and driving of the truck must be carried out when the foot switch is depressed.

8. Operating specification



Please follow the warning and safety instructions before operating the car (see as chapter 3)

Please Ensure that cargo or other equipment will not lead to poor visibility before operating the car

Ensure cargo level and stable placed .And conduct daily inspection .Insert the key into the key Switch(Figure 8),Turn the key clockwise to “ON” position. Before finally inserting the key switch (Figure 8),The emergency stop switch must be carefully pulled up.Press the horn button(as figure7 .8) to start the buzzer

8.1 Parking Pls Don't Park on the ramp



The car is equipped with an electromagnetic error protection Parking and Parking brake

During driving, you can brake by releasing the accelerator or the foot switch. Please always lower the forks completely and drive the car to a safe area. Turn the key counterclockwise to the OFF position and pull out the key

8.2 Loading capacity Graph

Do not overload, only increase the load capacity allowed by the load capacity graph

The loading capacity Graph shows a given load center c [Inch] and a car with horizontal load, the maximum load capacity Q [lbs.] In the corresponding lifting height of the truck H [Inch], The white markings on the frame indicate the range of lift that can be achieved. For example, a cargo's center of gravity distance c is 15.75Inch, the maximum lifting height H is 177.16Inch, and the maximum load capacity Q is 1540lbs

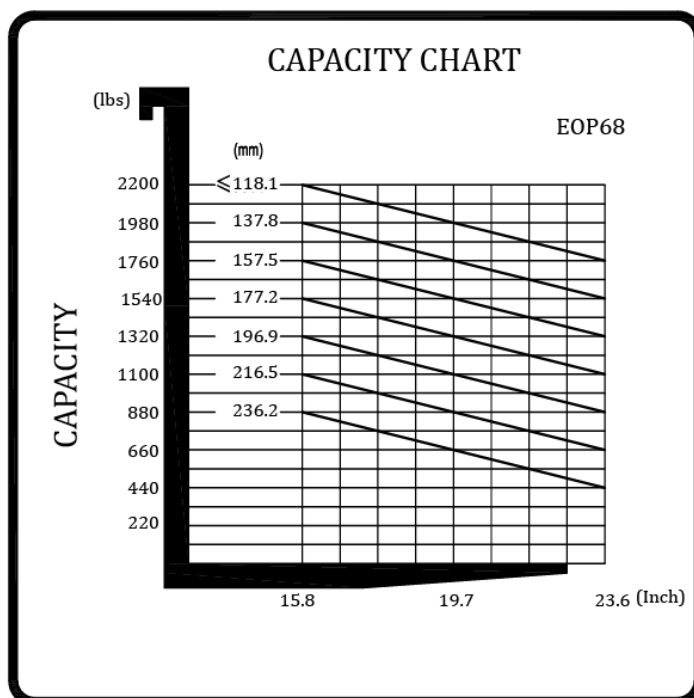

Figure 10 Loading capacity graph

8.3 Lifting up & lowering down

Step on the foot switch, then pull-down and lock the guardrails on both sides of the cockpit and control the mast main lifting and lowering by controlling the lifting & lowering joystick A rotate to B (as figure shows).

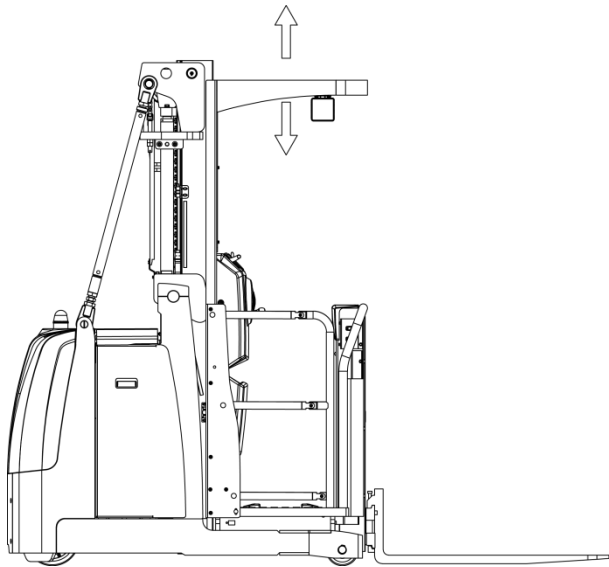

Figure 11 Door frame main lifting

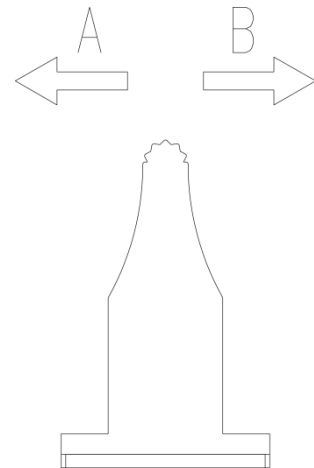

Figure 12 the lifting & lowering joystick

Use lift switch(Figure 9.1 shows) to control the rising and falling of the fork attached.

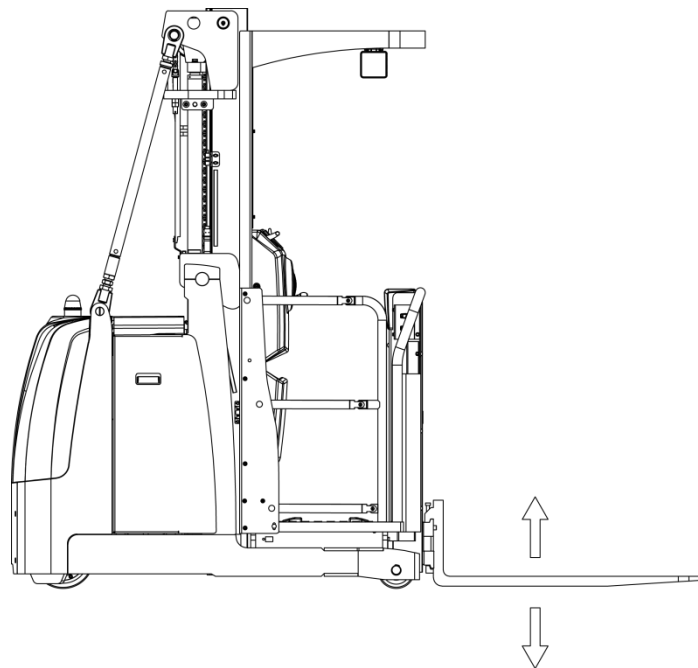

Figure 13 Fork lifting

8.4 Traveling

Only drive on the slope when the cargo are facing up

Don't drive on the slope in excess the specified specifications .

Only can driving when the fork falls to the lifting point (<11.81Inch)

- Turn the inserted key to the "on" position to start the Truck
- While depressing the foot switch, turn the accelerator button to the F direction to make the truck drive in the direction of 'Fw' or 'Bw' . Release the accelerator to return to the '0' position or release the foot switch to stop the truck
- By carefully turning the button (Figure 7.7) to control the driving speed until the desired speed is reached.
- Drive the vehicle carefully to the destination. Observe the road surface and adjust the driving speed through the accelerator.

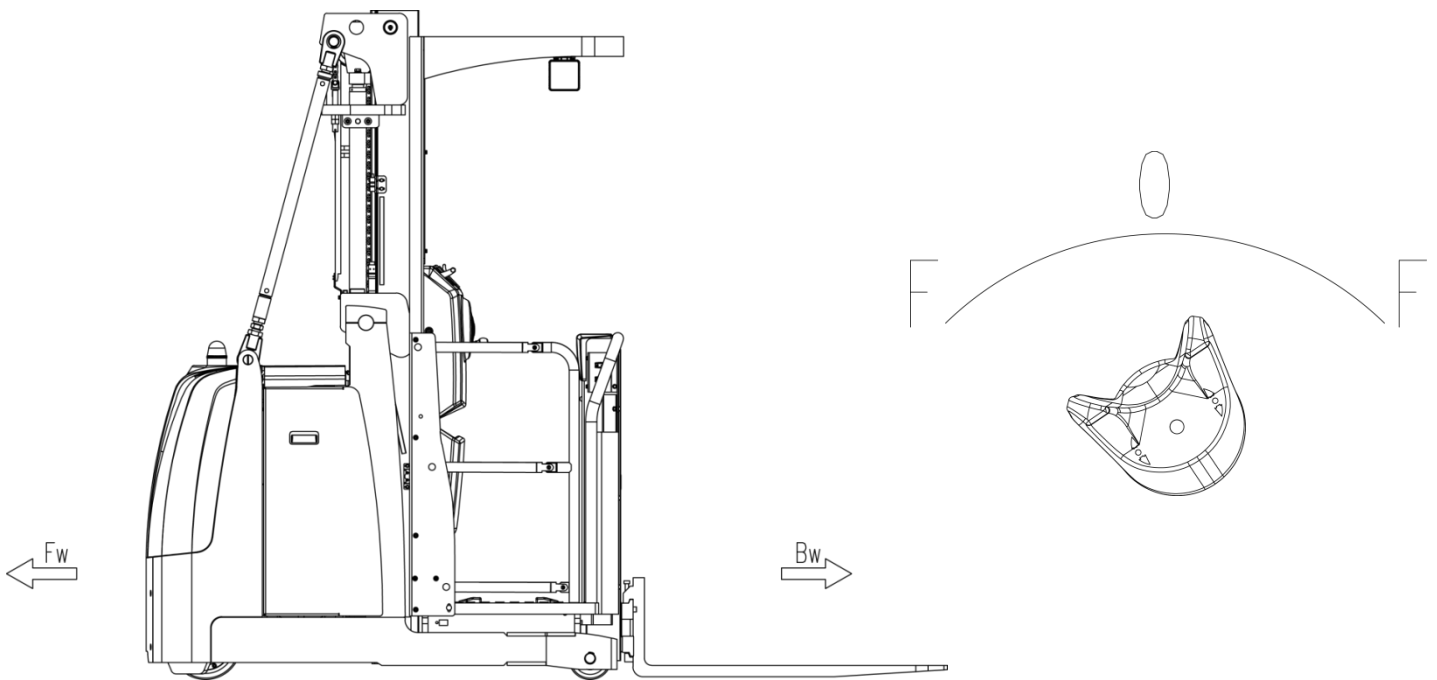

Figure 14.Operation diagram

8.5Steering

The truck is equipped with a power steering system, so be careful when operating.

Steering the truck by turning the steering wheel in the N direction or S direction

When driving in the driving direction(as shown in the figure15)rotate the steering wheel in the N direction, the truck rotates in the N direction, and the truck rotates in the S direction.

When fork direction driving (as shown in the figure15)rotate the steering wheel in the N direction, the truck rotates in the S direction, and the truck rotates in the N direction.

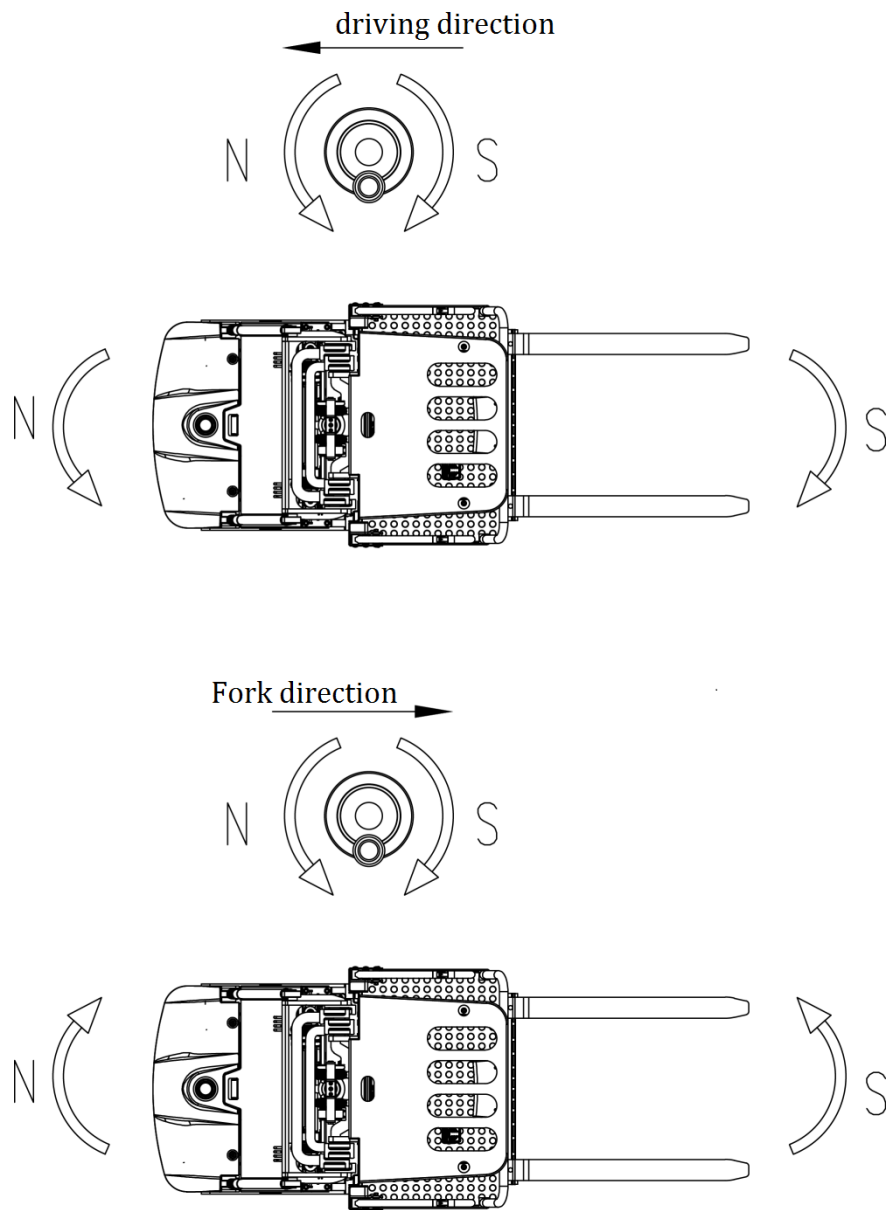
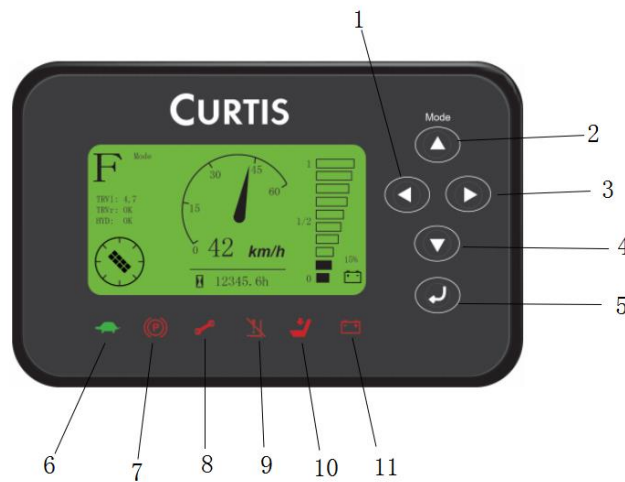

Fig:15 Steering diagram

8.6 Monitor

Curtis instruments are used to realize auxiliary control functions and provide a display interface for the driver's truck operating conditions. It is composed of control circuit, accumulated time counter (liquid crystal display), battery fuel gauge, fault code display and other display circuits. According to the current demand of electric trucks, this instrument has a brand new design in the control circuit and display form, which can provide the driver with intuitive truck status information, compact structure, beautiful appearance, high degree of automation, and reliable quality.

Curtis instruments provide operators with some simple information about the operating conditions of the vehicle mechanism. As shown as below



- 1. Parameter :
- 2. Speed mode switch key/parameter adjustment key (upward)
- 3. Parameter adjustment key (turn right)
- 4. Parameter adjustment key (turn down)
- 5. Parameter adjustment key (Enter)
- 6. Turtle speed indicator 7. Parking indicator light
- 8. Fault indicator 9. Lifting lock indicator
- 10. Seat switch (interlock) indicator light 11. Battery warning light

8.7 Braking

Braking performance depends on road conditions and the loading conditions of car



The brake function can be activated in the following ways :

- Move to the '0' position through the accelerator (Figure 14) or release the button, the regenerative braking is activated, and the truck brakes until it stops.

- By directly moving the accelerator button (Figure 7.7) from one driving direction to the opposite direction, the truck will regeneratively brake until it starts to drive into the opposite direction.
- Release the foot switch while driving to achieve truck braking.

8.8.Brake structure & Brake Schematic

Braking principle: as figure 11 shows including : Brake by magnetic yoke assembly 6、 Magnet exciting coil 7、 Spring 2、 brake disc 5、 Armature 1、 Geared sleeve 4、 Mounting screw 3 .The brake is mounted on the end cap of the motor ,and the mounting screw is adjusted to the specified air gap value. The gear sleeve is fixed on the shaft .The external teeth cooperate with the internal teeth of the brake disc. And the torque is transmitted during operation. then the brake disc can move axially on the gear sleeve .

When Magnet exciting coil 7 of brake is energized .the coil produces a magnetic field that caused the armature 1 draw toward the magnetic yoke assembly 6.Armature 1 detached from the brake disc 5(Release).Then the motor drive shaft with brake disc 5 start and operate normally. When Magnet exciting coil 7 is de-energized., The magnetic flux disappears .Armature 1 is released .and spring 2 process armature 1,then the friction plate on the brake disc is pressed to generate frictional force for braking purposes

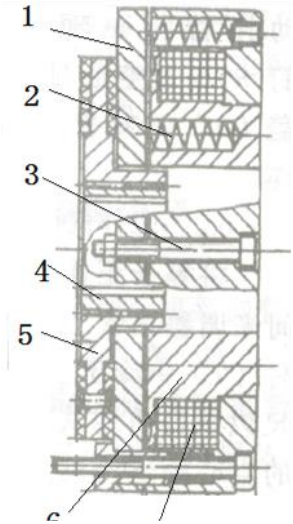

Figure 16 brake schematic

8.9Trouble

If there is any error or the car is not operate, Stop using and press the emergency stop switch. Parking the car in safe area if possible .Turn the key counterclockwise and remove the key(figure 10).Notify the manager or contact your after-sales service staff immediately .Use a special towing equipment /lifting equipment to pull the truck out of the operating area if necessary .

8.10Emergency situations

Keep a safe distance in an emergency situation or the car is turned over. Press the emergency stop switch and all electrical functions will stop.

9.Changing and Replacement for battery



- **Only Qualified personnel are allowed to repair or recharge the battery .Please be sure to follow this manual and battery manufacturer's instructions.**
- **The battery is Lead-Acid battery.**
- **Battery recycling is subject to national regulations .Please follow these rules .**
- **When handling batteries .Don't use open flame which may cause gas explosion.**
- **Don't place flammable materials and work equipment that may generate sparks within a distance of at least 6.56ft around the forklift that needs to be recharged**
- **It is forbidden to burn materials or burn liquid in the charging area of the battery. It is strictly forbidden to smoke. The area must be well ventilated.**
- **Parking the car safely before you start charging ,installing /replacing the battery**
- **Before finishing the repairing .please make sure that all cables are connected and there is no interference to the other part of car .**



Only lead-acid batteries are allowed

The battery weight has a certain influence on car operation .Please consider the max working temperature of the battery.

9.1Replacement

Park the car safely, Lower the fork to the lowest point .Turn off the car by key(Figure8) and press the emergency stop switch, Take off the battery side

panel and the battery baffle, remove the battery connector, pull out the battery from the side of the frame and hang it out. Caution: If the lifting equipment is not safe. The battery may tip over .Installation is the opposite procedure of remove , Please connect the positive terminal firstly .Otherwise the car is easy to damage

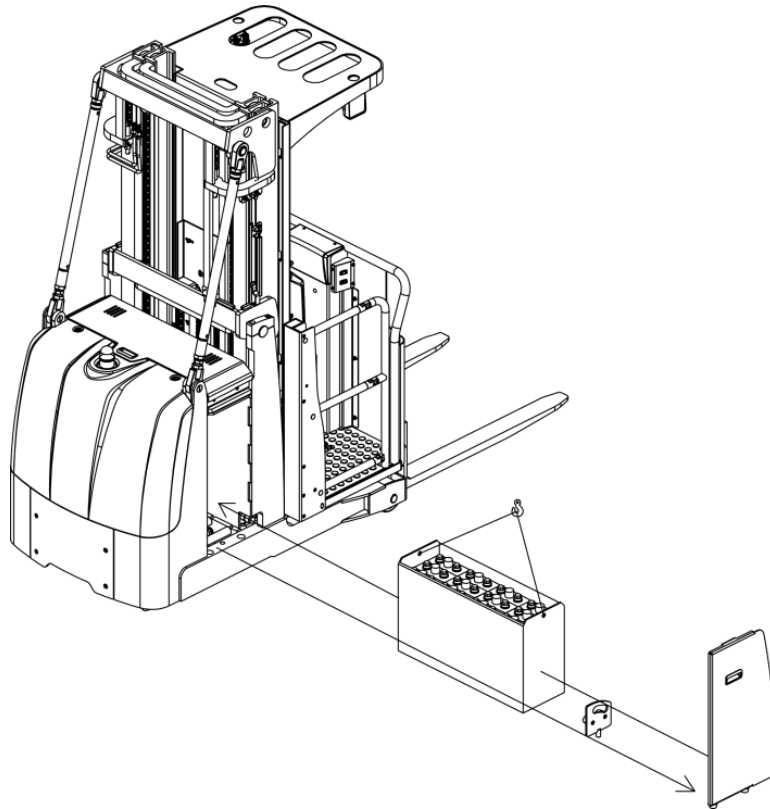

Figure 17.Battery replacement

9.2 Charging



- Only be charged with included charger
- Before using the charger ,Please fully understand the contents of the charger manual
- Ensure good ventilation in charging room

Park the car in a safe area that provide dedicated power .Lower fork , and remove the cargo. Turn off the power of car, Open the battery cover, then connect the connector and Charger. The charger starts charging .Finishing charging .Remove the connector from the charger, Connect the connector to the car and cover the battery cover .

Battery specification :24V/280Ah ,Charger specification :24V/40A

10. Maintain Introduction



- Only Qualified and trained personnel are allowed to maintain the car .
- Remove the cargo from the fork and lower the fork to the lowest point before maintenance .
- Please use the designated binding equipment or lifting equipment in accordance with chapter 4 ,if it is necessary to lift the car .Before operation .Place safety device(such as lifting jacks,Wedges or Wooden blocks)under the car to prevent accidental falling ,moving or sliding .
- Use approved and distributor 'S original accessories .
- Please consider the machine failure and accident that may be caused by the leakage of hydraulic oil.
- Only trained maintenance technicians are allowed to adjust the pressure Valve .

Check the key point on the maintenance list

10.1 Maintenance list

Table 6 Maintain list		Time interval(Month)			
		1	3	6	12
No.	Hydraulic system				
1	Check if there is any damaged noise and leakage for hydraulic cylinder and piston		•		

2	Check if there any damage and leakage for Hydraulic connector and tubing .		•		
3	Check hydraulic oil level and refill if necessary.		•		
4	Refill hydraulic oil(12 months or 1500 working hours)				•
	Mechanical system.				
5	Check the fork for deformation and cracks		•		
6	Check the base for deformation and cracks		•		
7	Check all screws are fully fixed		•		
8	Check the mast & chain for corrosion. Deformation or damage ,And replace if necessary	•			
9	Check the gear box for noise and leakage		•		
10	Check the wheels for deformation and damage and		•		
11	Lubricated steering bearing				•
12	Check and lubricate the pivot point		•		
13	Grease fitting	•			
14	Protect, protective plates and replace it if they are	•			
	Electric system				
15	Check the wires for damage		•		
16	Check electrical connections and terminal conditions		•		
17	Check the function of Emergency stop switch		•		
18	Check the electric motor for noise and damage		•		
19	Check the display		•		
20	Check if the fuse is used correctly and replace if necessary		•		
21	Detection buzzer		•		
22	Check the current contactor		•		
23	Check the frame for leaks (Insulation test)		•		
24	Check the function and wear of the accelerator		•		
25	Check the electrical system of the drive motor		•		
	Braking system				
26	Check the braking performance		•		
	battery				
27	Check the battery voltage		•		
28	Clean and grease the terminal ,Check for corrosion and		•		
29	Check if battery box damage		•		
	Charger				
30	Check if the main power cord is damage			•	
31	Check the start protection procedure during charging			•	
	Function				
32	Detection buzzer	•			
33	Check the air gap for electromagnetic braking	•			
34	Check emergency braking function	•			
35	Detect reverse braking and regenerative braking	•			
36	Check steering function	•			
37	Check lift up & lift down function	•			
38	Check key switch for damage and function	•			
39	Check speed limit switch(lifting height >~400mm)	•			

	Comprehensive				
40	Check if all labels are clear and complete	•			
41	Check if the shield panel and protection is not damaged	•			
42	Check the caster ,to height adjust or replace it if worn		•		
43	Conduct a test run	•			

10.2 Lubrication point

Lubrication point according to the maintenance list .required grease specification :DIN:51825

1..Drive gear

2.Joint bearing

3. Chain

4.Door frame roller

4.Front wheel bearing

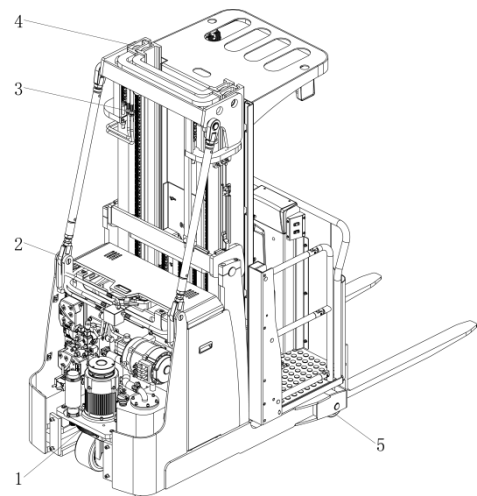

Figure 18 lubrication point

10.3 Check and refill hydraulic oil

Required hydraulic oil type:

- H-LP 46, DIN 51524
- Viscosity 41.4 – 47
- According to the model, the amount of oil depends on the height

Waste material such as waste oil, Waste batteries or other materials must be treated and recycled in accordance with the national regulations, It should be send to the recycling company for recycling .if necessary. The oil level should not be lower than the min amount oil required to lift cargo .Add oil to filling point if necessary.

10.4 Check the electrical fuse

Remove the cover ,The fuse is located as figure 19.

The fuse specification is shown in table 7

table 7 fuse specification

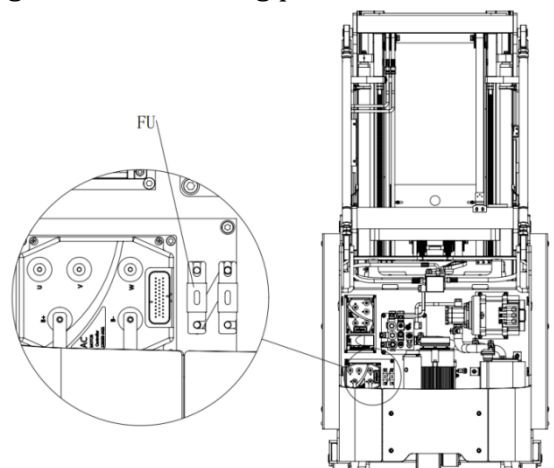

Code	Specificatio	Otv
FU1	300A	2

10.5 Remove and reinstall the shield

Figure 19 Fuse

Do not use the car if the shield is damaged or not installed properly.

If the shield needs to be removed, unscrew the fixed screw and carefully remove the shield, the screw is still on the shield. When reinstalling, place the shield in the correct position and secure each screw properly. If you need to replace parts, please contact your nearest after-sales service partner.

11.Trouble shooting

- If the car is still in trouble ,please follow the instruction in chapter 6

Table 8 Fault analysis

Effect of fault	Cause	Solution
Cargo can' t lift up	Overload	Lift the cargo weight indicated in Name plate
	Battery discharge	Charging the battery
	Fuse damage	Check the fuse, replace it if necessary
	Hydraulic oil level is too low	Check and fill the hydraulic oil
	Oil spill	Check the tightness of the tubing and / or cylinder
	Sensor failure	Check the sensor on the mast
Oil leakage due to inhalation	High oil quality	Reduce oil quality
The truck can't work	The battery is charging	Fully charge the battery, then unplug the main power plug from the power supply
	Battery connector is not connected	Check the battery connector and connect if necessary
	Fuse damage	Check the fuse
	Battery discharge	Charging the battery
	Emergency stop switch is activated	Insert and pull the knob to eliminate the emergency stop switch function
One direction move	Accelerator and connector damage	Check Accelerator and connector
Move slowly	Battery discharge	Check the battery status on the display
	Activated electromagnetic brake	Check electromagnetic brake
	The relevant handle harness is not connected or damaged	Check handle harness and connector
	Lower speed at height 15.75Inch and sensor failed	Check speed
	Electrical system overheating	Stop using and cool the car
	Error occur in heat sensor	Check and replace the heat sensor if necessary
Start suddenly	Controller is damaged.	Change the controller
	The accelerator was not moved back to its intermediate position	Check and replace the accelerator

The forklift is not in operation	Battery plug not plugged in	Check and plug the battery plug
	Emergency stop switch pressed	Release the emergency stop switch
	The switch lock is off	Open the switch lock
	Low battery	Charge the battery
	Damaged safety device	Check the safety device

If the car breaks down and can't be operated outside the working area, Lift the car up. Place a loading device under the car and keep the car safely, Then move the car out of the aisle

12.After-sales service

If there is a fault that cannot be eliminated by professional service personnel, please contact our after-sales service personnel in timer

13. Electrical Schematic diagram

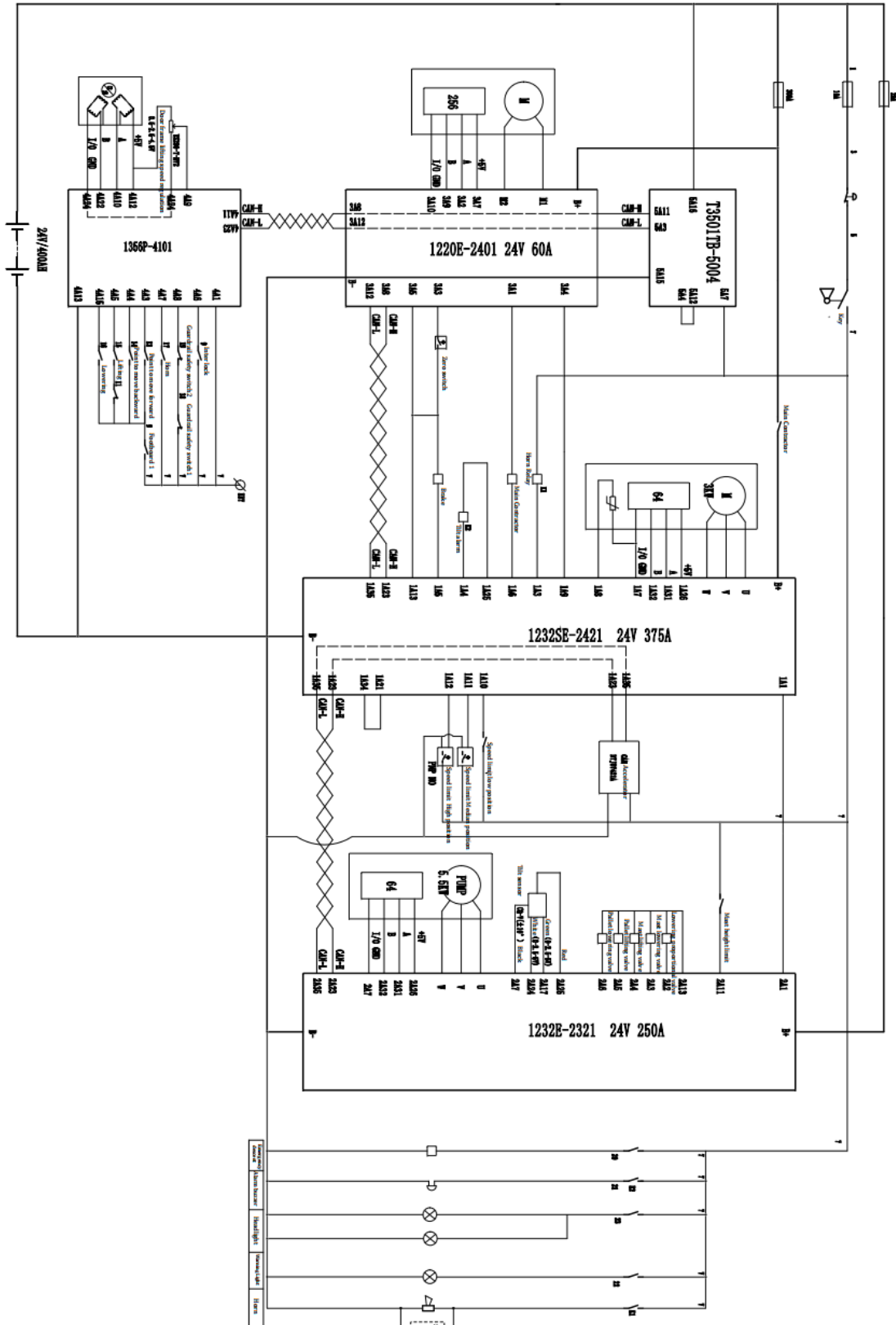

14. Hydraulic Schematic diagram

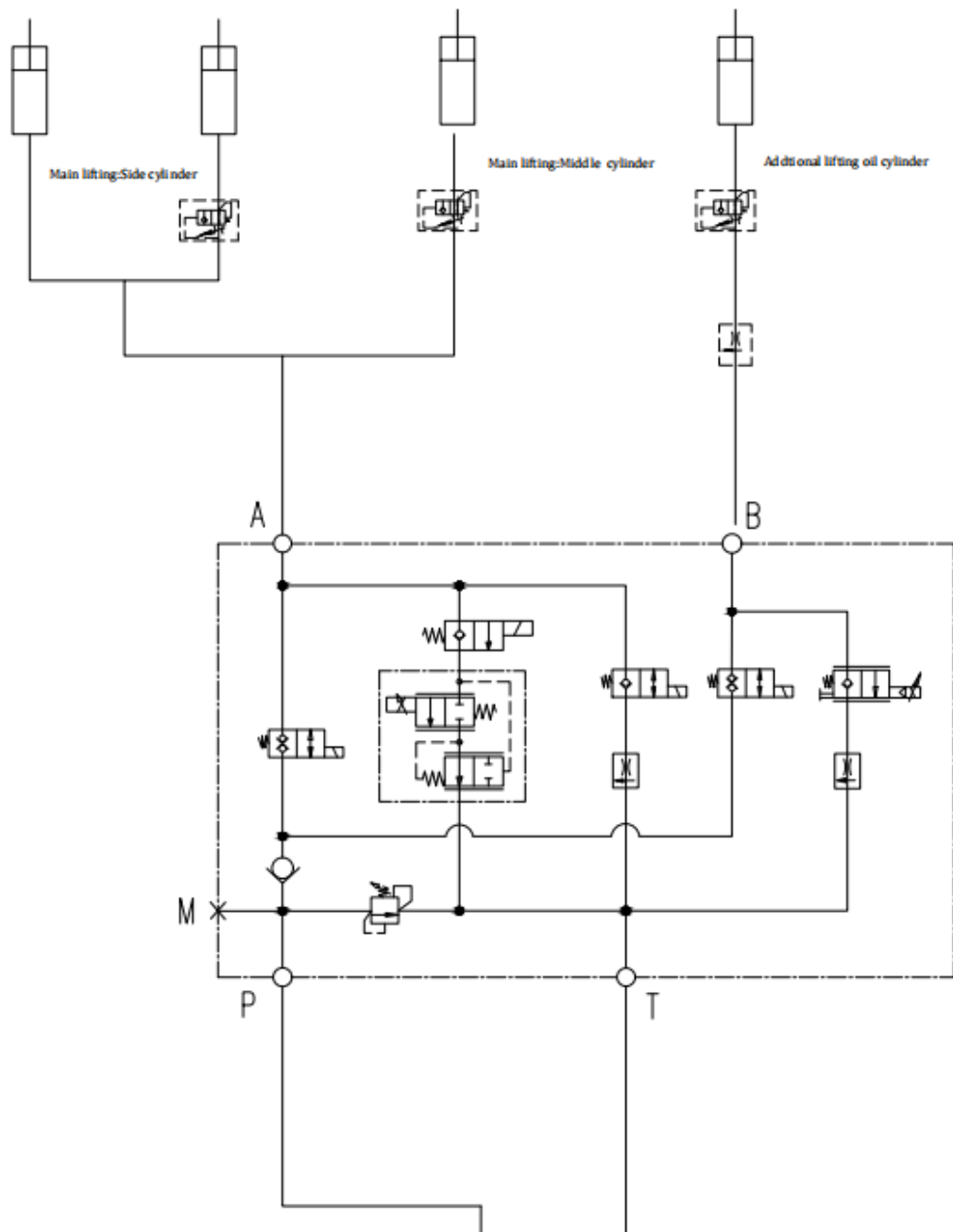

This manual final interpretation retained by manufacturers.