

# EKKO<sup>®</sup>

MATERIAL HANDLING EQUIPMENT

**MOVING AHEAD**

## LITHIUM WALKIE PALLET JACKS

**EP15JLIC / EP18JLIC / EP20JLIC**

- Lithium Powered
- 3300-4400 lbs. Capacity
- Forks 27x45"
- Internal Charger
- Polyurethane Wheels
- Pinwheel Capability
- Electromagnetic Braking
- Lithium Iron Phosphate  
24Volt 30-40 AH/ 48 Volt 20 AH
- DC Drive Motor



## EP15JLIC/EP18JLIC/EP20JLIC

Superior quality, maneuverable, compact, and durable for all your material handling applications. Ideal for small aisles and areas.

Model		EP15JLIC / EP18JLIC / EP20JLIC
Power Type		Electric
Operation Type		Walk-behind
Rated Load	Q(lbs)	3300 / 4000 / 4400
Load Center Distance	c(in)	23.62
Front Overhang	x(in)	37.6
Wheelbase	y(in)	50.3
Wheel Material		Polyurethane Wheel (PU)
Drive Wheel Diameter x Width	Φxw(in)	Φ8.27 x 2.95
Load Wheel Diameter x Width	Φxw(in)	Φ2.91 x 3.66
Maximum Lift Height	h3(in)	7.48
Handle Height	h14(in)	48.2
Height When Fork is Lowered	h13(in)	2.95
Overall Length	l1(in)	64
Fork Dimensions	s/e/l(in)	2.24/6.30/45.28
Fork Outer Width	b5(in)	26.8
Minimum Ground Clearance	m2(in)	1.06
Minimum Aisle Width (1200*1000)	Ast(in)	88.9
Minimum Aisle Width (800*1200)	Ast(in)	83.9
Minimum Turning Radius	Wa(in)	57.5
Travel Speed (Full Load/Empty Load)	mph	2.6/2.8
Maximum Gradient, Full Load/Empty Load	in/s	0.24/0.39
Braking		Electromagnetic Brake
Drive Motor Power	kw	0.75
Lift Motor Power	kw	0.8
Battery Capacity	V/Ah	Lithium Battery 24V/40Ah
Lithium Battery Charger	V/A	24/12
Drive Control Method		DC
Steering Method		Mechanical Steering

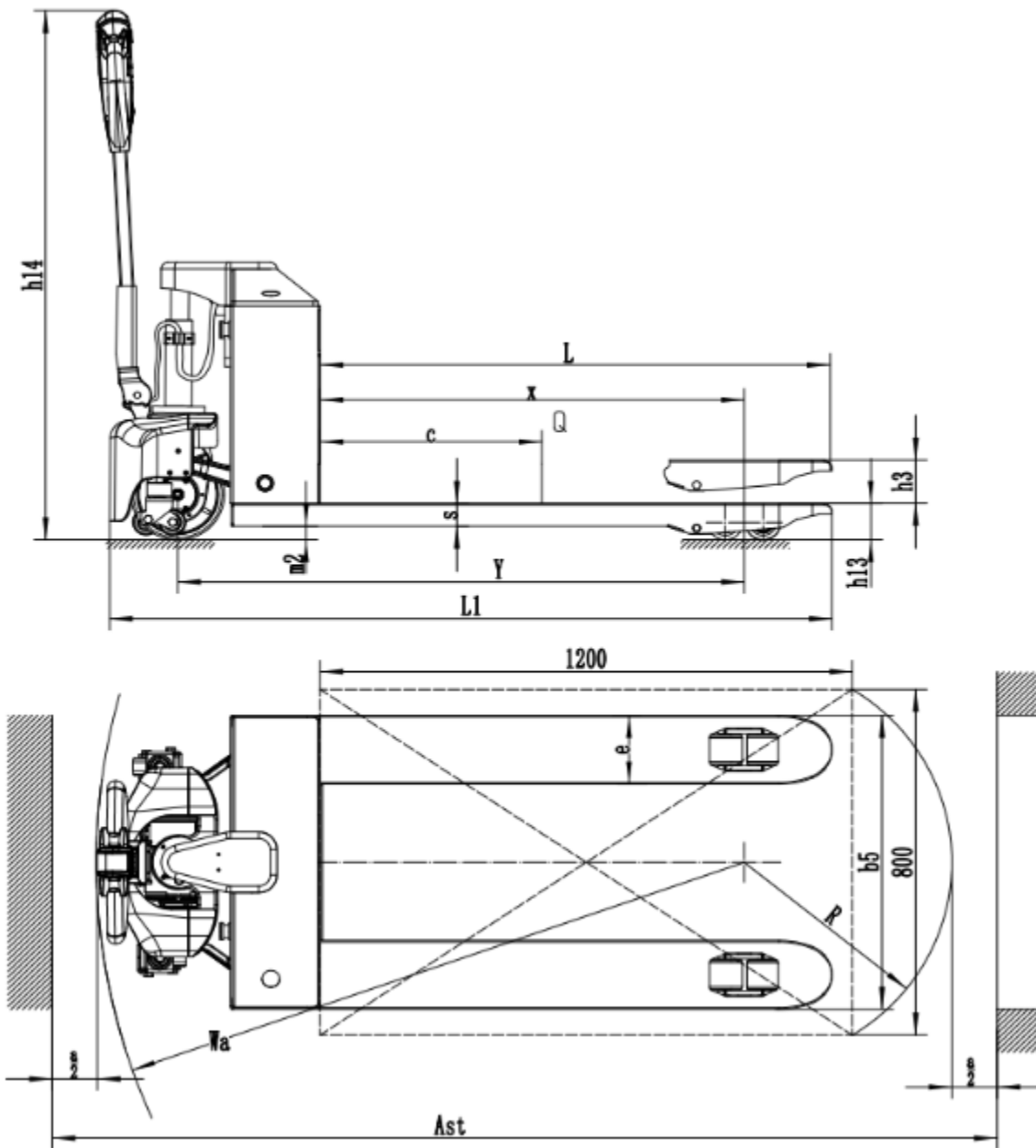

MODEL #	LOAD CAPACITY	FORKS	Lithium BATTERY	SERVICE WEIGHT
EP15JLIC	3300lbs	27x45	24V/30Ah	328 lbs.
EP18JLIC	4000lbs	27x45	24V/40Ah	346 lbs.
EP20JLIC	4400lbs	27x45	48V/20AH	359 lbs.