

EKKO

MATERIAL HANDLING EQUIPMENT

MOVING **AHEAD**

LITHIUM WALKIE PALLET JACKS

EP15JLI / EP18JLI / EP20JLI

- LITHIUM LiFePO4
- 3300-4400 lbs. Capacity
- Forks 27x45"
- Internal Charger
- Compact & Economical
- Polyurethane Wheels
- Pinwheel Capability
- Electromagnetic Braking
- Lithium Iron Phosphate
24Volt 30-40 AH/ 48 Volt 20 AH
- Batteries and Charger Included
- 3 Year Limited Warranty
- New With Pin Pad



EP15JLI/EP18JLI/EP20JLI

Superior quality, maneuverable, compact, and durable for all your material handling applications. Ideal for small aisles and areas.

WEIGHT CAPACITY: 3300-4400 lbs.

RAISED HEIGHT: 7.8"

LOWERED HEIGHT: 3.35"

FORK LENGTH: 27x45"

TURNING RADIUS: 53.7"

BATTERY / CHARGER: LITHIUM IRON PHOSPHATE

Lithium 24V-48V/20-40AH, Internal direct connect 110A
110VAC plug-in automatic 24V/15A charger (both Included)

SPEED TRAVEL: 2.8 mph empty; 2.6 mph loaded

MINIMUM GROUND CLEARANCE: 1.38"

DRIVE WHEELS: 9.84" polyurethane

LOAD WHEELS: (2) 3.15 X 3.35 polyurethane

HYDRAULICS LIFTING MOTOR: 24V 800 Watt lifting motor with hardened chrome moly steel for durability.

DRIVE MOTOR: 24V/750-Watt drive motor for efficiency and high torque.

CONTROLLER CURTIS: 24V provides performance through entire range of speed; Constant travel speed regardless of load; Battery discharge indicator.

BRAKES: Electro-magnetic braking for secure stopping power; Electronic neutral braking for accurate control.

OPERATOR CONTROLS: Throttle, lifting, lowering, turtle mode and horn functions are in the ergonomic handle; turtle button; belly button reverse safety feature allows the unit to stop and reverse to avoid collision or injury.

CHASSIS AND MAST: Robotic Welding; Heavy duty steel for durability.



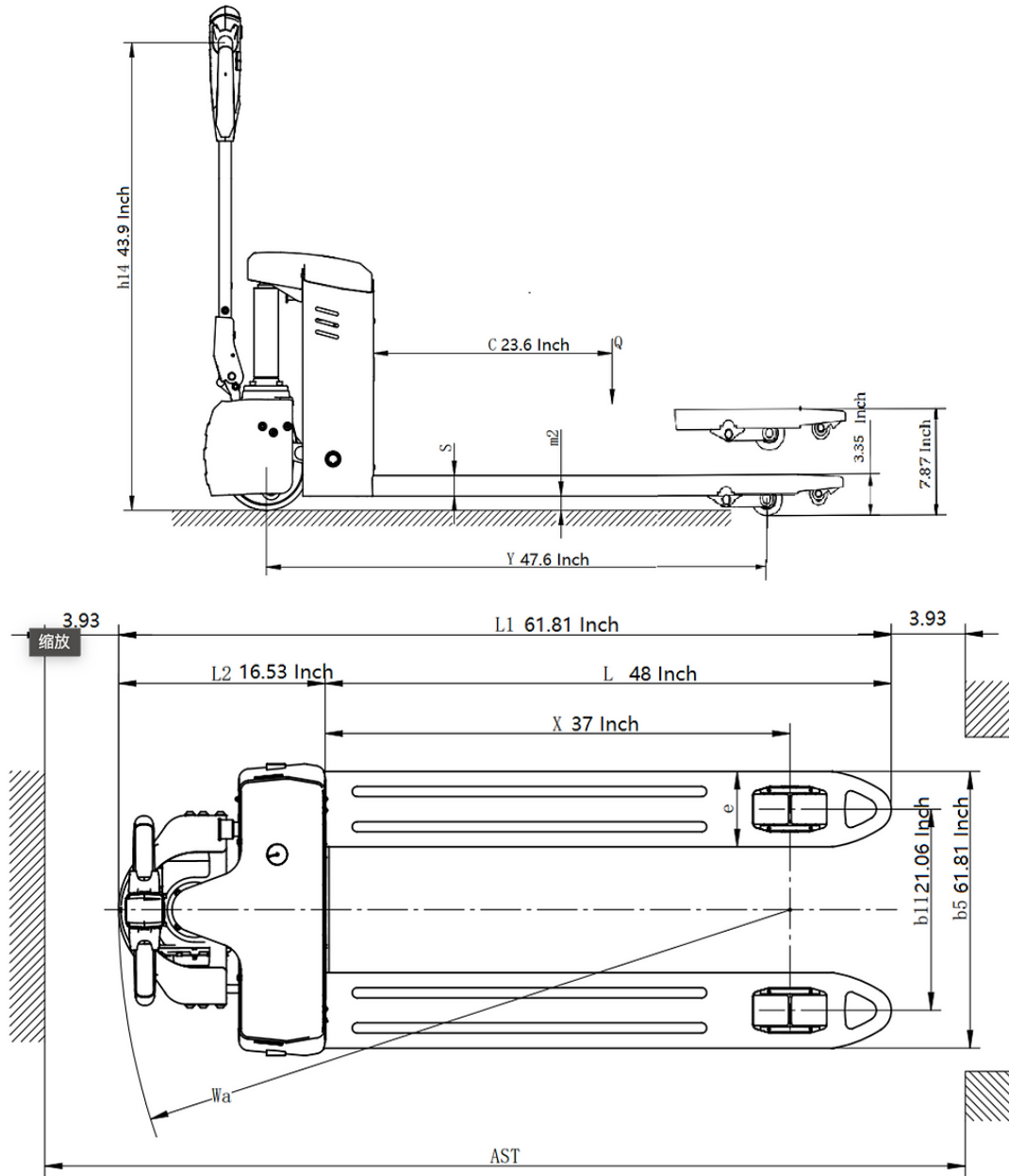

MODEL #	LOAD CAPACITY	FORKS	Lithium BATTERY	SERVICE WEIGHT
EP15JLI	3300lbs	27x45	24V/30Ah	308lbs
EP18JLI	4000lbs	27x45	24V/40Ah	319lbs
EP20JLI	4400lbs	27x45	48V/20AH	326lbs