

EKKO®

MATERIAL HANDLING EQUIPMENT

MOVING AHEAD

Instruction Manual

Internal combustion engine powered

FORKLIFT

EK20TLP/ EK20D

EK25TLP/ EK25D

EK30TLP/ EK30D

EK35TLP/ EK35D

EK40TLP/ EK40D

Thanks for your purchase of EKKO product

This Operation & Maintenance Manual was written to provide the owner/operator with information about the safe operation and maintenance of the forklifttruck. Read this manual thoroughly and become completely familiar with the lift truck before using it. If you have any questions, see your dealer.

Due to improvements in design, it is possible that the description contained herein may not completely apply to the truck delivered to you.

CONTENTS

1. SAFETY

2. OPERATING CONTROLS

3. OPERATION

4. MAINTENANCE

5. SPECIFICATIONS & SERVICE DATA

CAUTION

If the truck is to be leased, loaned or sold to anyone, this manual must be with the truck.

CAUTION

Please refer to the corresponding engine maintenance manual for specific engine maintenance instructions.





1. SAFETY

CONTENTS

FOR SUPERVISORS.....	1- 2
Proper and Improper Uses.....	1- 3
Planning and Working Area.....	1- 4
Traveling on Public Roads.....	1- 7
Operators.....	1- 8
Types of Vehicles and Loads.....	1- 10
Inspection.....	1- 13
Transporting the Lift Truck.....	1- 14
How the Lift Truck Works.....	1- 16
Traveling.....	1- 19
Load Handling.....	1- 24
Parking.....	1- 28
Inspection and Service.....	1- 29
Points of attention in use of e series engines.....	1- 35
Caution Plates.....	1- 39

The following symbols, found throughout this manual, alert you to potentially dangerous conditions to the owner and the operator. Become completely familiar with the truck before proceeding with operating, checking and servicing the truck.

This manual and the decals affixed to the truck use the following safety alert indications.

SIGNAL WORD	CLASSIFICATION
 DANGER	Failure to follow the instructions in the message will likely cause a serious accident or death.
 WARNING	Failure to follow the instructions in the message might cause a serious accident or death.
 CAUTION	Failure to follow the instructions in the message may cause personal injury or damage to the truck or other property.
 NOTE	The information will help to prolong the service life of the truck. The message is not directly related to accident prevention.

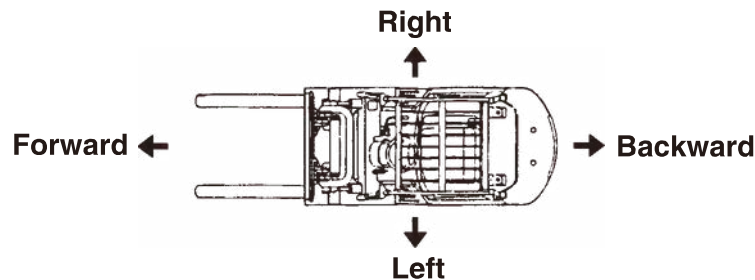

The diagram above indicates the meanings of the terms "forward", "backward", "right" and "left" used in this manual

FOR SUPERVISORS

Lift truck accidents cause dozens or hundreds of deaths every year, and even greater numbers of personal injuries.

has steadily improved the design and fabrication of our lift trucks so they may be used more safely and efficiently, but many accidents still occur due to improper use. Accidents are often the result of more than just "bad driving". The use of inappropriate types of equipment, the selection of inappropriate attachments or accessories, in appropriate operating environments, careless designation of operators, and failure to properly train the operator are other common causes of accidents.

This chapter covers the methods of accident prevention which are primarily the responsibility of supervisory personnel.

- Pages 1-2 through 1-15 contain instructions which should be enforced by the personnel supervising the operation of the lift truck. Please make sure the operators also read these pages.
- Page 1-16 and the following pages contain specific precautions directly related to the operation of the lift truck.

FOR SUPERVISORS PROPER AND IMPROPER USES

■ PROPER USE OF THE LIFT TRUCK

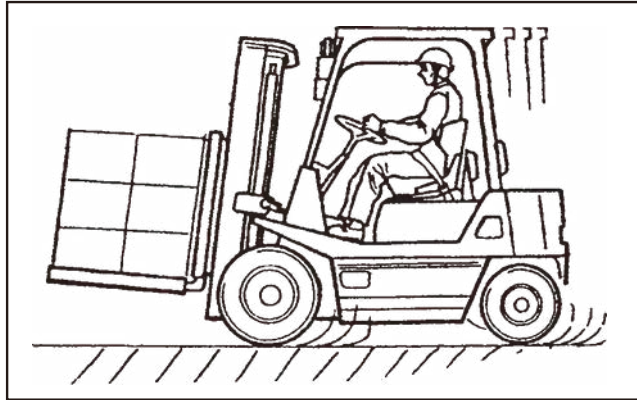

The proper use of a lift truck is to transport a load which is placed on the pallet and stacked within the prescribed height limit.

With a proper attachment, a lift truck may be used to transport a load which is stacked elsewhere than on the pallet.

■ IMPROPER USE

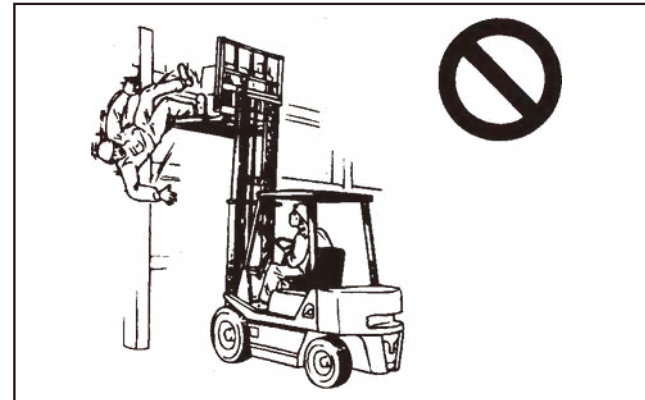

Transporting a person, elevating a person, and towing another vehicle are examples of the improper use of a lift truck. Uses which this manual specifies as improper must never be requested or permitted, under any circumstances.

(Examples of Improper Use)

- Transporting or elevating a person on the forks or pallet.
- Carrying a person on the pallet to control the load.
- Touching a cable with the forks to suspend a load.
- Towing another vehicle.
- Pushing a load or another vehicle with the forks.
- Using the forks or truck body to close or open the door of a freight vehicle.

FOR SUPERVISORS PLANNING AND WORKING AREA

■ MAKE AN OPERATING PLAN AND DISCUSS IT

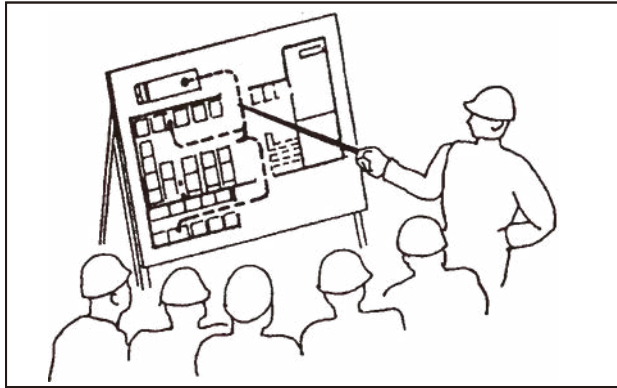

Before using the lift truck, plan out the travel routes and operating procedures, and thoroughly discuss the details with all involved personnel.

■ SET SPEED LIMITS

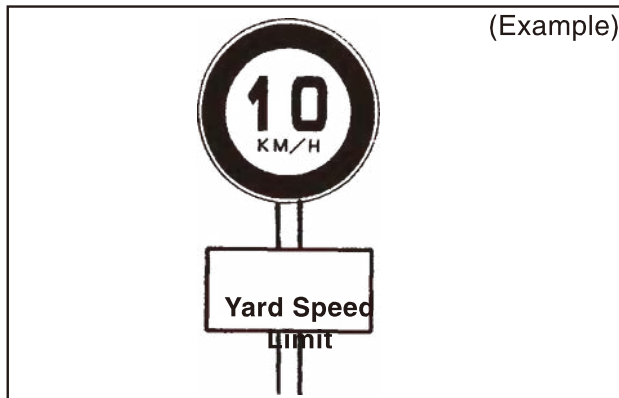

Set appropriate speed limits on your company grounds, and post signs that are clearly visible.

1 - 4

■ INSTALL CURBS OR RAILINGS

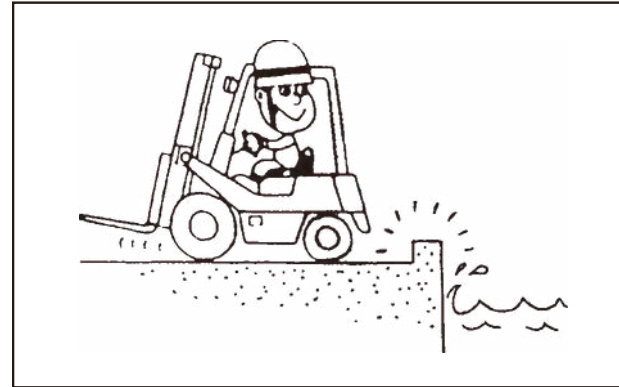

If the truck is to be used on a loading dock, shore wall or other raised surface, install curbs or railings.

■ MARK THE TRAVEL LANES

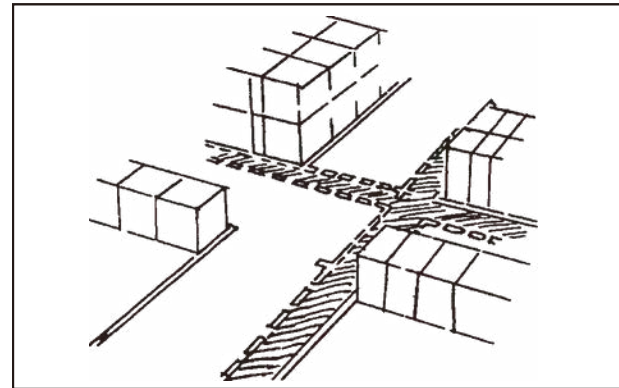

Designate the travel lanes for the lift truck and mark them clearly, so they will be kept free of obstruction.

FOR SUPERVISORS **PLANNING AND WORKING AREA**

■ KEEP PEOPLE OUT OF THE OPERATING AREA



No other personnel should be allowed in areas where the lift truck is used.

Where other people must be present, post a guide whose job is to make sure people stay clear of moving vehicles.

■ KEEP UNAUTHORIZED VEHICLES OUT

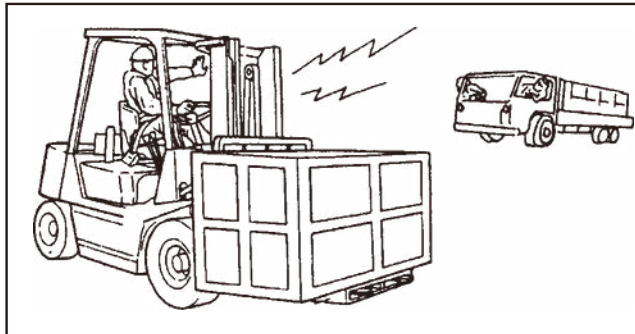

Unauthorized vehicles must be kept out of the load handling areas. Post signs or give signals as required.

■ KEEP THE GROUND LEVEL AND DRY

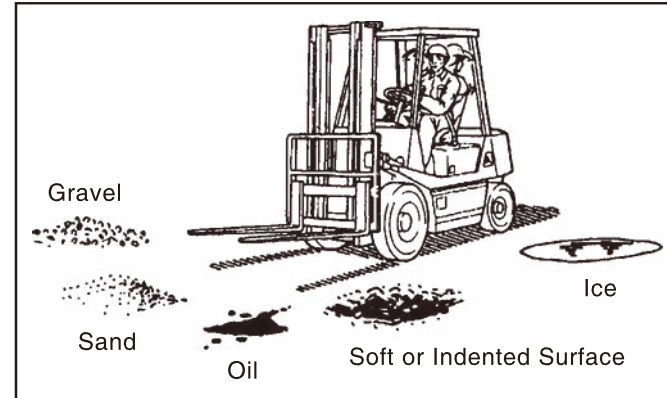

Be sure that all areas where the lift truck travels are level and regular. Clear away pools of oil or water.

■ PROVIDE ADEQUATE LIGHTING

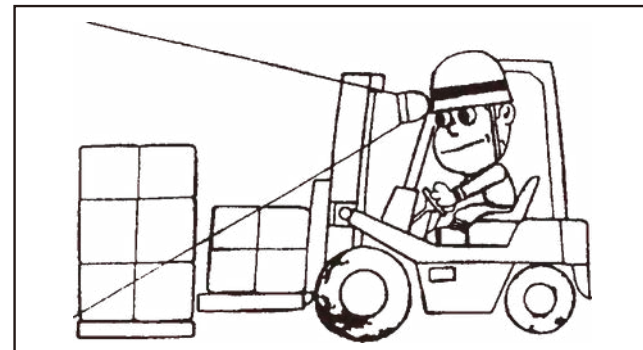

Safe operation requires well-lit traveling routes, so pedestrians and obstacles can be easily seen. Use headlights, taillights, helmet lamps or other lights as appropriate.

FOR SUPERVISORS PLANNING AND WORKING AREA

■ ASSIGN TRAFFIC GUIDES TO CONGESTED AREAS

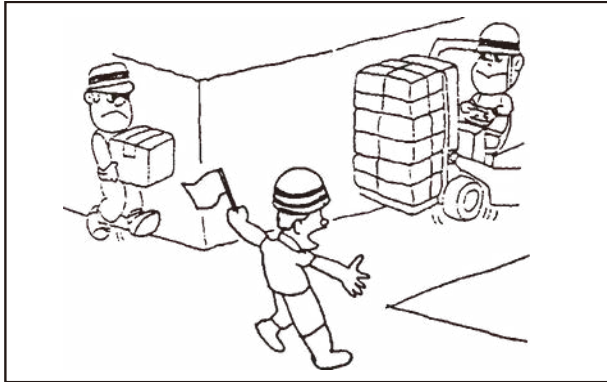

Post a traffic guide in confined or congested areas where other people or vehicles may pass. All personnel must obey the guide's signals.

■ KNOW WHO TO CALL IN AN EMERGENCY

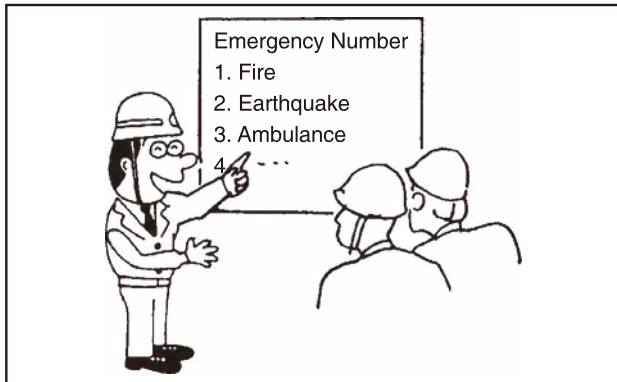

Keep information on hand to allow immediate calls for help in case of a fire, accident or other emergency.

■ PROVIDE AND MAINTAIN EMERGENCY EQUIPMENT

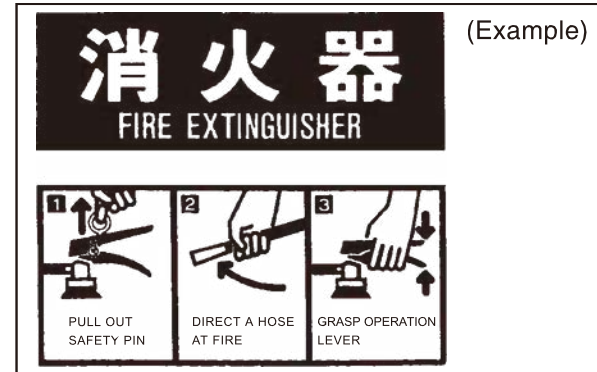

Fire extinguishers and first aid kits should be provided and maintained for use in case of a fire or accident. All personnel should understand the location and use of emergency equipment.

■ SAFETY MEASURES FOR DANGER SPOTS



Post warning signs or take other appropriate measures to ensure that lift truck operators keep away from danger spots as they travel.

FOR SUPERVISORS TRAVELING ON PUBLIC ROADS

■ GOT A LICENSE?



Before traveling on a public road, be sure that the truck has been licensed and inspected as required by local laws.

■ NO LOAD, NO TOWING

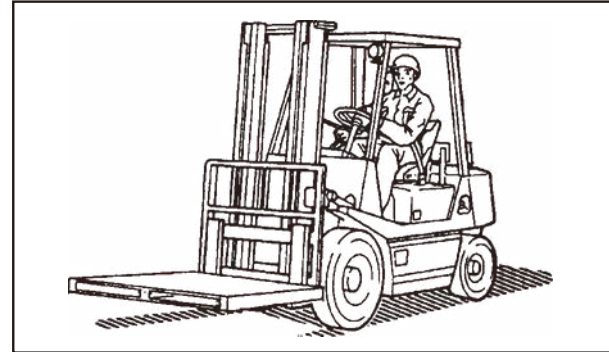

It is usually illegal to carry a load on a public road. It is also not allowed to make a sideways travel or tow another vehicle on a public road (with the possible exception of a disabled vehicle). Never tow another vehicle, even on company property.

■ OBEY TRAFFIC LAWS, AND TURN OFF YOUR LIGHTS

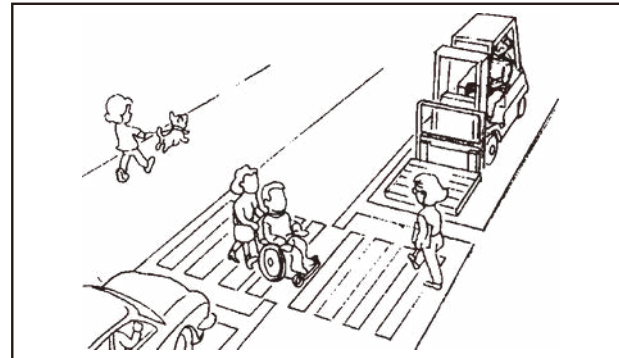

On a public road, the lift truck must obey the same laws as any other vehicle. Do not use rear working light.

FOR SUPERVISORS OPERATORS

■ WEAR PROTECTIVE GEAR

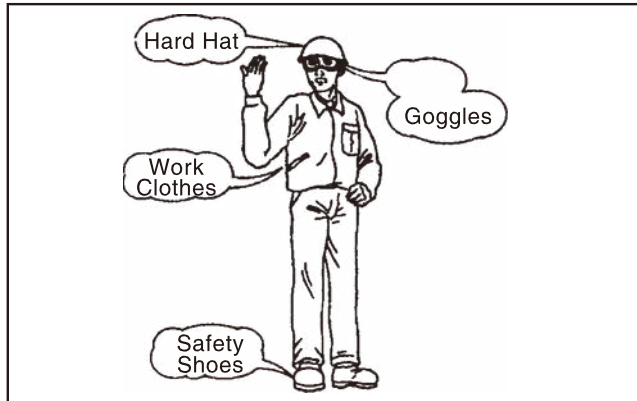

- Always wear proper work clothes for driving. Work clothes should be designed to prevent any part from accidentally catching on knobs or other parts of the truck or equipment. For example, shirts and trousers should have tight cuffs.
- Always wear a hard hat and safety shoes. Wear other protective gear as appropriate to the conditions of the work site, i.e., goggles or gloves.

- ### ■ PERSONNEL WITHOUT LICENSE IS NOT ALLOWED TO DO THE OPERATION.
- The operator must take good training and instruction.

■ TRAIN YOUR STAFF TO STACK SAFELY

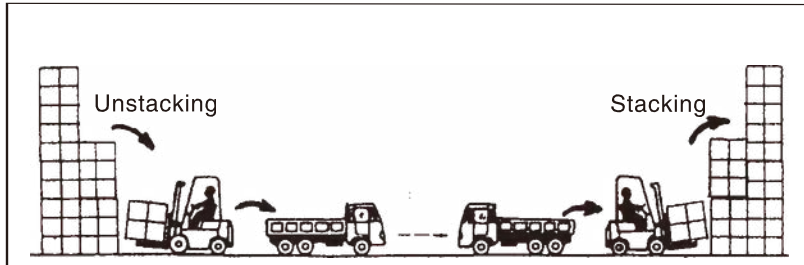

"Stacking" means piling palleted load or materials directly on top of each other, without using racks or shelves to separate them. If the stacking work is not done properly, the loads may slip or fall, endangering the operator as well as any other personnel in the area.

Safety classes should be held to train all operators in the proper methods of stacking and unstacking loads. (Your dealer can provide information about training for safe stacking.)

■ TIMELY TRAINING AND INSTRUCTION IS NECESSARY FOR THOSE EXPERT OPERATORS.

- Each 5 years : technical improvement will cause the change of fabrication of lift trucks. The laws will be changed too.
- Significant modification to lift trucks: make sure the new training and equipment is proceeded through according to the modification.

Timely training should be taken for the high development of truck's fabrication, micro-computer and other equipment. The laws is often revised as well.

We still suggest those who has understood very well to attend the lecture by lift truck experts.

■ TIRED OR UNWELL? SEND THEM HOME!



Do not let people take chances. An operator who is overworked or fatigued, an operator who is feeling unwell, or an operator who is intoxicated must not be allowed in the driver's seat.

FOR SUPERVISORS TYPES OF VEHICLES AND LOADS

■ USE THE RIGHT TRUCK FOR THE JOB

Be sure the type and capacity of the lift truck is suitable for the work environment.

Check Point	Choice
Capacity	Load capacities range from 0.5 to 42 tons. Pay particular attention to the load center. (TCM Lift Truck Capacities: 0.5, 0.7, 0.9, 1, 1.35, 1.5, 2, 2.25, 2.5, 2.75, 3, 3.5, 4, 4.5, 5, 6, 7, 8, 10, 10.5, 11.5, 12, 13.5, 15, 18, 20, 22, 23, 24, 25, 30, 37, or 42 tons.)
Power Source	Gasoline, natural gas, diesel, and battery-powered models are available. Fuel costs and exhaust composition will vary.
Balance	On counterbalanced models, the counterweight at the rear makes the vehicle longer than reach trucks. A reach truck performs loading and unloading by extending the front part of the mast outward, which gives it the advantage of compactness.
Tires	For indoor use, there are models with solid tires (best for reach trucks) and cushion tires (engine type or battery type). Both are compact. For outdoor use, pneumatic tires work well. Solid cushion tires, with the same dimensions as pneumatic tires, may be the best choice in cases where the load materials or surface conditions could puncture pneumatic tires.
Flammable Materials	For handling flammable materials such as petrochemicals, a combustion engine is too dangerous. An electric vehicle with explosion-proof or safety-reinforced construction is required. (A battery power source always offers better protection against fire than a combustion engine.)

■ USE THE PROPER ATTACHMENT

Popular Attachment Examples

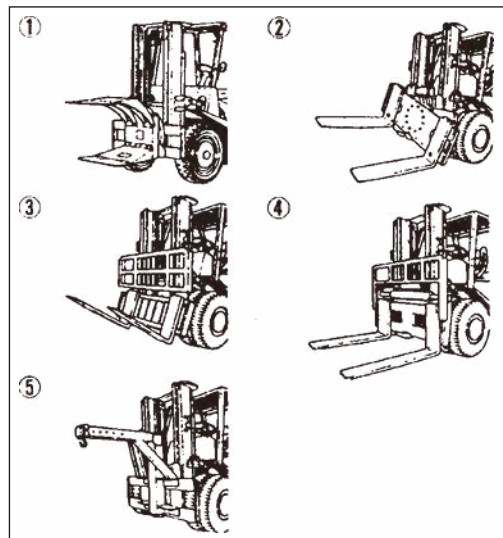

- ① : Roll Clamp
(For paper roll or drum handling)
- ② : Rotating Fork
(For damping work or charging work)
- ③ : Hinged Fork
(for lumber handling)
- ④ : Side Shift
(For precise stacking in containers or other narrow spaces)
- ⑤ : Crane Arm
(For slinging work)

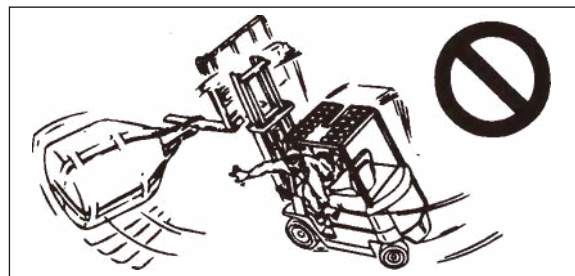

⚠ WARNING

Avoid hoisting a load with wire rope hung from the forks or an attachment, or avoid lifting a freight container with forks, because there is danger of the truck tipping. If necessary, have a qualified operator use a hook or crane arm attachment.

FOR SUPERVISORS TYPES OF VEHICLES AND LOADS

■ NO OPERATION WITHOUT LIGHTS, OVERHEAD GUARD, OR BACKREST



The lift truck cannot be used if the headlights, taillights, overhead guard, backrest, horn or turn signals have been removed. Any parts that have been temporarily removed for some reason must be reattached immediately.

■ OBTAIN APPROVAL FOR ANY MODIFICATION



Modifications or additions that affect the capacity, construction or strength of the truck must not be performed by the user without the manufacturer's prior permission. For example, don't add a counterweight.

■ KEEP DECALS LEGIBLE

The decals on the truck describe safety precautions and operating instructions. Replace any damaged or missing decals. Check that the decals are legible during regular inspections.

■ DO NOT RELY ON THE OVERHEAD GUARD

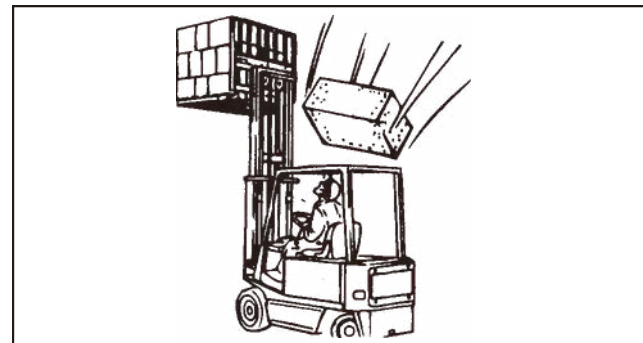

The overhead guard is a protective device that will moderate the impact of an object falling from overhead, but it cannot withstand every impact. If a heavy object seems likely to fall on the truck, make every effort to prevent it from doing so.

FOR SUPERVISORS TYPES OF VEHICLES AND LOADS

■ HAVE A GOOD VENTILATION



When the engine is run indoors such as in an enclosed warehouse, have a fresh-air ventilation. Exhaust fumes can cause chemical poisoning, and in the worst case exhaust fumes can kill. When warming up or operating the truck indoors, open the windows and doors or use a fan to make sure there is a good ventilation.

■ USE STURDY PALLET MATERIALS

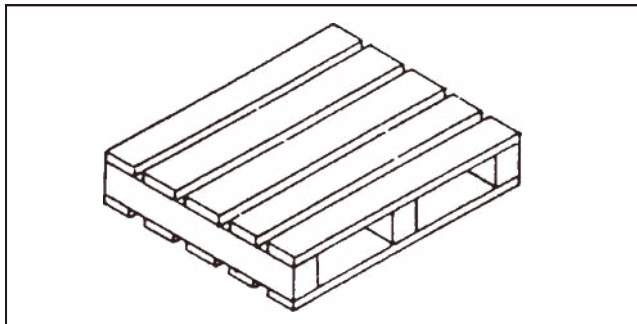

Pallets and skids must be strong enough to withstand the heavy weights of loading and unloading. Remove or repair any damaged pallet.

1-12

■ STACK LOADS SECURELY

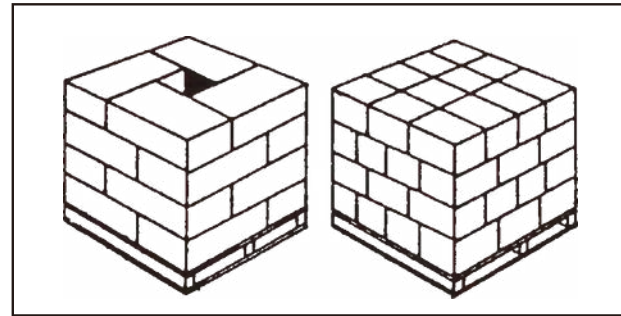

When stacking loads, place them in stable manner that they will not easily come apart, and be sure the weight is evenly distributed. Secure the top layer with a cord wrapped like a headband or in a similar fashion.

■ KNOW THE WITHSTAND LOAD OF YOUR FLOOR



The lift truck is heavier than it appears. For example, a 2-ton truck weighs almost 3.5 tons even when empty. Furthermore, when loaded, 80 to 90% of the total weight is concentrated on the front wheels. Check the strength of your floors and roadways, and if necessary reinforce them.

FOR SUPERVISORS INSPECTION

■ ALWAYS INSPECT BEFORE OPERATING

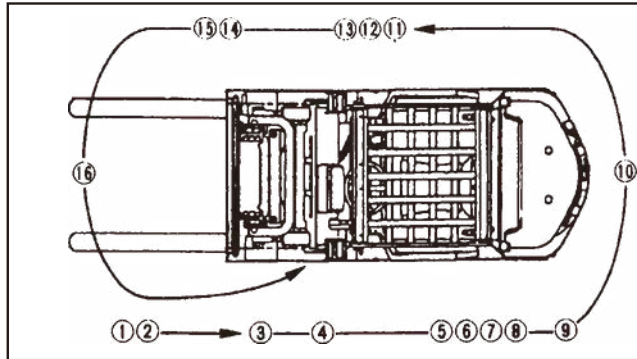

The operator should always inspect the truck before each use to verify that all essential safety features are working. Any abnormality is to be reported to the supervisor, who is responsible for correcting it.

■ PERIODIC INSPECTIONS ARE MANDATORY

Monthly and annual inspections must be performed thoroughly, and any abnormality promptly repaired. Only a certified expert who has the advanced skills and equipment is allowed to conduct inspections. Preserve the inspection logs for at least three years.

■ REPLACE SAFETY PARTS REGULARLY

	Part	Recommended Replacement Interval (year)
1	Master cylinder and wheel cylinder cups and dust seals	1
2	Power steering hose	2
3	Reserve tank tubing	2 - 4
4	Fuel hose	2 - 4
5	Torque converter rubber hose	2
6	Rubber parts inside power steering unit	2
7	Lift chain	2 - 4
8	Load handling means hoses	1 - 2

Certain critical parts must be replaced at regular intervals. Since it is difficult to detect wear on the above parts by visual inspection, they must be replaced at the intervals specified, because a failure would result in a falling load or runaway truck.

■ NEVER USE AN UN-MAINTAINED TRUCK

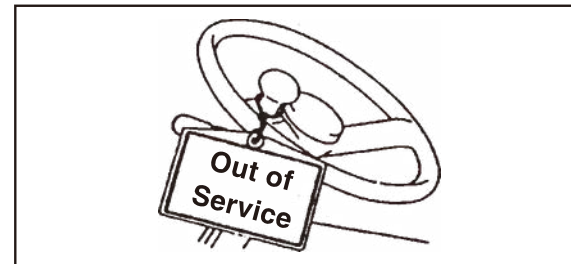

A truck that has not passed an inspection must never be operated. Hang a sign on the truck and remove the ignition switch, to make sure no one uses it. Then report the problem to the supervisor and wait for the repair to be completed.

■ DESIGNATE A REPAIR AND ASSEMBLY SUPERVISOR

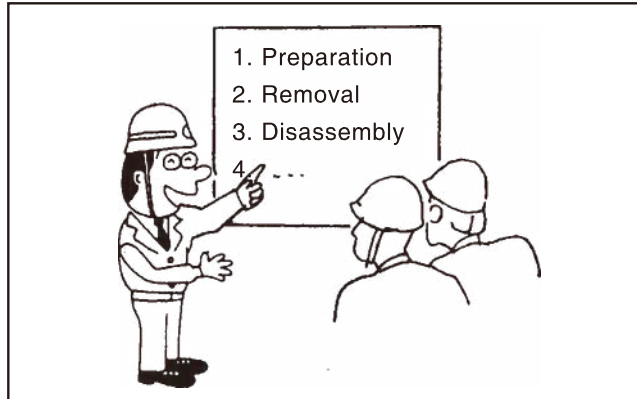

Repairs and the mounting and dismounting of attachments must be performed under the direction of a designated supervisor. The body and major parts of the lift truck are quite heavy and under very high pressure. Repair or assembly work undertaken without careful and thorough preparation can lead to serious injury.

■ TRANSPORTING THE LIFT TRUCK

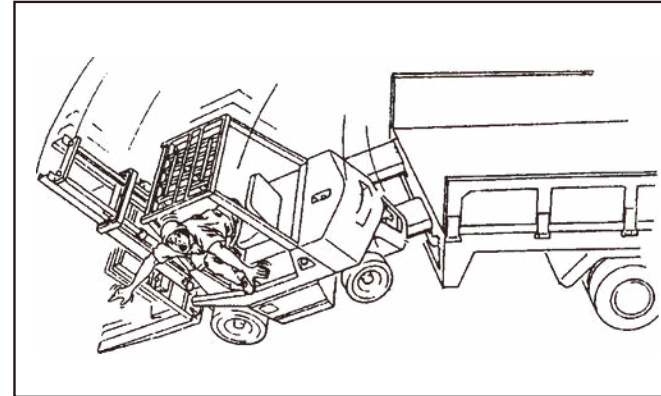

Use a level, hard road surface when loading the truck onto or unloading from a trailer and when unloading it. Be certain that the ramps have sufficient length and width as well as strength. Do not load or unload the truck when it is raining, unless the ramps are fitted with an anti-slipping surfaces. It is safest to use a self-loading trailer truck equipped with a jack and winch. For loading, tilt the pallet with the jack, attach the winch to the towing pin of the lift truck, and pull it up. The operator must not ride on the lift truck during loading or unloading.

FOR SUPERVISORS INSPECTION/TRANSPORTING THE LIFT TRUCK

- Use optional "Lifting Eyes" for lifting your lift truck

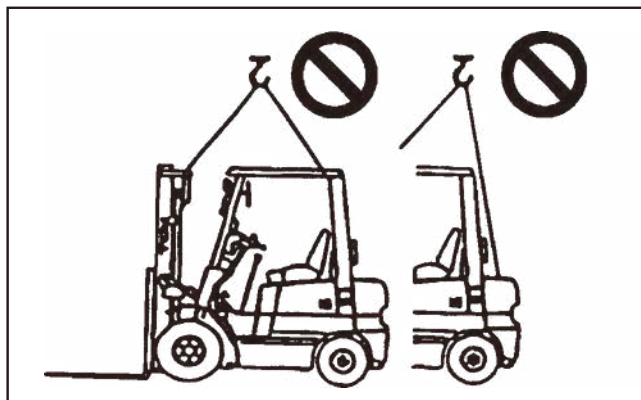

⚠ WARNING

Never hoist your lift truck at its overhead guard or counterweight; otherwise there is a danger of the truck falling.

If hoisting the lift truck is necessary for any reason, use optional "Lifting Eyes."

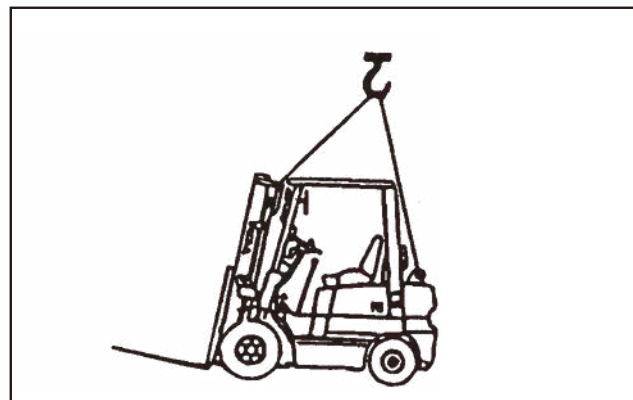

⚠ WARNING

Observe the following conditions when lifting the lift truck:

- Use optional "Lifting Eyes."
- Use ropes strong enough to withstand the weight of the truck.
- Do not use any wire rope which is kinked, deformed or frayed.
- Lifting the truck should be performed only by qualified personnel.
- Do not enter under a lifted truck.

HOW THE LIFT TRUCK WORKS?

■ KEEPING THE TRUCK BALANCED

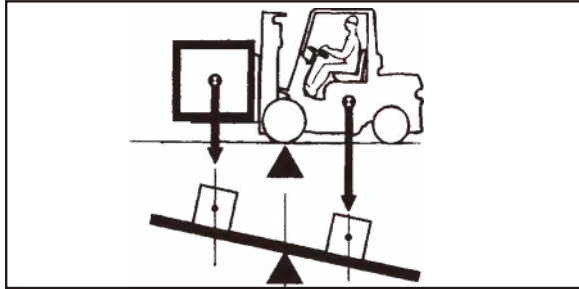

Lift trucks are equipped with load handling means including a mast and forks at its front part. The front wheels of the truck work as a fulcrum to balance the center of gravity of the truck and the center of gravity of the load. The relationship between the locations of those two centers of gravity is vitally important for safety.

■ KNOW THE CENTER OF GRAVITY OF YOUR LOAD

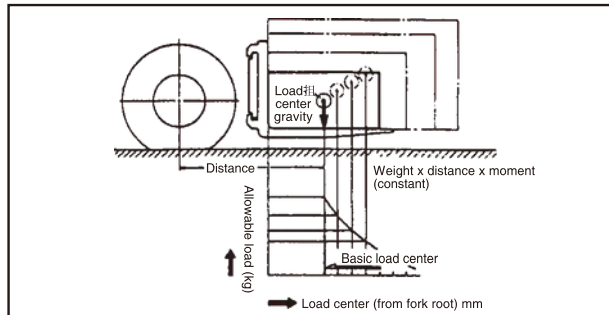

Materials of various shapes such as boxes or flat or cylindrical items may be loaded on the lift truck. In order to accurately judge the stability of the truck, it is vitally important for the operator to

know the location of the center of gravity for each type of load

■ HOW THE CENTER OF GRAVITY SHIFTS

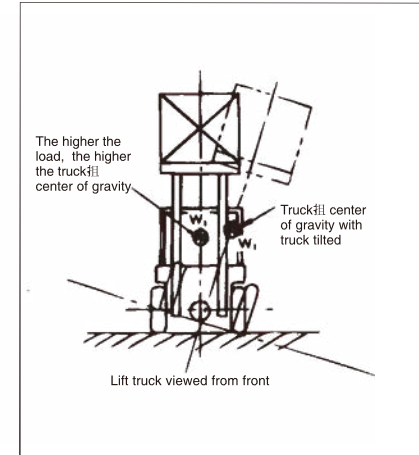
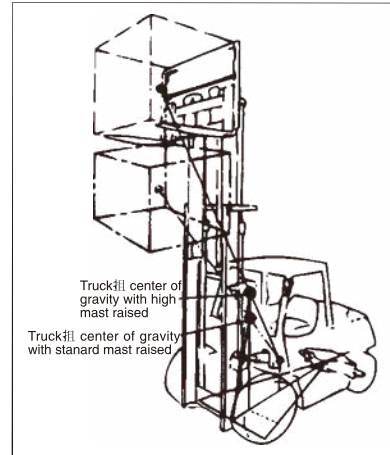

The stability of the lift truck is determined by the overall center of gravity, which is the product of the centers of gravity of the truck and the load. When the truck is empty, this point is the same as the center of gravity for the truck, and when it is loaded it shifts according to the center of gravity of the load. Since the center of gravity of the load changes whenever the mast is tilted forward or backward or the fork is raised or lowered, the overall center of gravity also changes. The center of gravity is also governed by the following factors:

- Size, weight and shape of the load
- Unloading height
- Tilt angle of the fork
- Tire material
- Acceleration, deceleration and turning Surface condition and gradient of the road Type of attachment

HOW THE LIFT TRUCK WORKS?

■ OUTSIDE THE TRIANGLE OF BALANCE, THE TRUCK TIPS

For a lift truck to remain stable, the overall center of gravity must be inside the triangle formed by the contact points of the left and right front tires and the center point between the steering wheels. The triangle defines the area of stability for the center of gravity. If the overall center of gravity moves further forward than the front wheels, the truck will tip forward with the front wheels as the fulcrum. If the overall center of gravity moves outside the triangle to the right or the left, the truck will fall over in that direction.

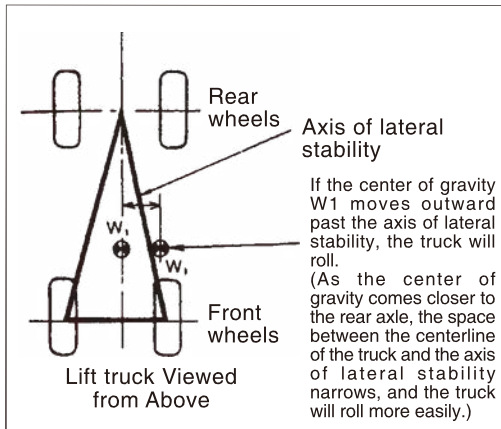

■ RATED LOAD (LOAD WEIGHT AND LOAD CENTER)

The load center is the distance from the front face of the forks to the center of gravity of the load. The rated load is the maximum weight allowable with the nominal load center.

The load Chart, showing the relationship between the load center and the rated load, is attached to the truck as a decal. The rated load decreases as the load center moves toward the tip of the forks, and as the overall center of gravity moves forward.

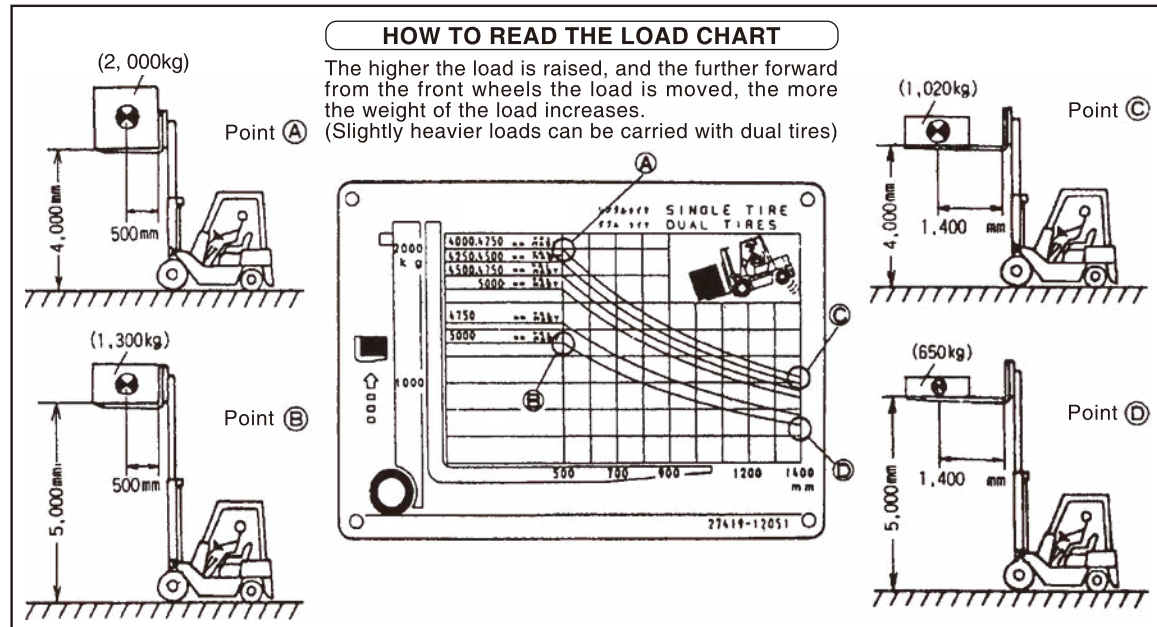

HOW THE LIFT TRUCK WORKS?

■ ACCELERATING, DECELERATING AND TURNING

The principle of inertia provides that a stationary object will remain stationary as long as there is no external force acting on it, and that a moving object will continue moving at a constant speed as long as there is no external force acting on it. Due to inertia, when the lift truck starts to move there is a momentary backward force, and when it stops there is a momentary forward force. As a result, if the brakes are applied suddenly, there is a very strong hazard that the forward force will become strong enough for the truck to tip forward.

Likewise, when the truck is turning there is a centrifugal force that pulls it outward from the turning center. This force can cause the truck to fall sideways. Since the zone of lateral stability is especially narrow, it is necessary to slow down substantially when turning in order to prevent the truck from tipping.

When the load is elevated the overall center of gravity is raised, increasing the danger of the truck tipping over to the front or side.

⚠ Read manual and decals



Read the Operation & Maintenance manual and caution plates on the truck, and become familiar with your truck and operating procedures. Remember that individual lift trucks might be different in design and construction from one another. Observe the caution decals on the truck. Keep this Operation and Maintenance manual on the truck as a ready reference for anyone who may drive or service it.

⚠ When starting the engine

When starting the engine, make sure to:

- Apply the parking brake securely.
- Place the direction shift lever and speed range shift lever (C type) or shift lever (T type) into neutral.
- Press the clutch pedal (C type) or brake pedal (T type).
- Adjust the steering column angle and driver's seat position before starting the engine.
Do not try to adjust them during operation otherwise a serious accident might occur.
After adjustment, make sure they are securely locked.
- Make sure there is no one under or around the truck, and start the engine.

⚠ Before reversing the direction of travel, bring the truck to a complete stop

It is dangerous to reverse the direction of travel abruptly.

⚠ Carry the load low

It is dangerous to travel with forks lifted higher than is appropriate, regardless of whether loaded or not. Keep the load as low as possible while traveling. Do not turn the truck with the load raised high.

⚠ Keep the truck's center of gravity low during traveling (when loaded in particular)

When traveling (when loaded in particular), keep the forks 20 cm above the floor or ground and tilted back, so as to lower the truck's center of gravity as far as possible.

⚠ Do not jerk the forks (lift, down, and tilt) when loaded



The truck might tip over

⚠ Avoid sharp starts, stops and turns



Start, stop and turn slowly. Before turning, slow down the truck sufficiently. In particular, an unloaded truck might tip over when it is turned sharply, because the rear of the truck is heavy.

TRAVELING

⚠ Back down and drive up

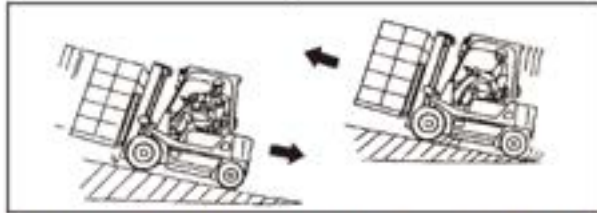

- Do not make turns on a gradient. There is danger of the truck upsetting.
- Keep the forks and pallet at an appropriate ground clearance height.
- When operating an unloaded truck on grades, have the rear end of your truck pointed up-hill.
- When operating a loaded truck on grades, have the rear end of your truck pointed down-hill.
- When descending a grade, use engine braking.

If the truck goes faster than you want, press the foot brake pedal from time to time. While using engine braking, do not operate the shift lever(s) nor press the inching pedal.

⚠ Stay away from the edge of road



There is a fear of the edge of a soft ground breaking. Stay away from such a place. Keep appropriate distance from the edge of a narrow road or a piltuorm.

⚠ When driving over a dockboard



- Do not ride on the edge of the dockboard or bridgeplates; otherwise the truck might fall down, leading to personal injury or even death.
- Before driving over a dockboard or bridgeplate, make sure it is properly secured. Never exceed its rated capacity. Do not use a damaged dockboard or bridgeplate.
- Have the brakes set and wheels blocked in place to prevent the trailer from moving.
- Jacks must be installed to support the trailer when the truck goes into the trailer.
- Drive carefully and slowly across the dockboard or bridgeplate.
- Watch for bystanders.
- Give instructions to the trailer driver not to move the trailer until load handling is finished.
- Make sure the dockboard or bridgeplate is secured.

⚠ Never use man as an additional counterweight



Do not use man as an additional counterweight. Do not offer rides to others.

⚠ Reverse travel



When traveling in reverse, always look in the direction of travel. Do not rely too much on the sideview mirrors (if so equipped) and backup buzzer.

⚠ Have a guide when handling bulky loads



When handling bulky loads which restrict your vision, operate the truck in reverse and have a guide.

⚠ Preoperational checks

Do not start your shift until preoperational checks are finished. If any problem is found, report to your supervisor and take necessary measures.

⚠ Keep sideview mirrors, backup alarm, and lamps in good working condition

Adjust the sideview mirrors to gain a full rear vision and keep the mirror's surface clean (if so equipped). The backup buzzer should sound when the direction change lever is placed in the reverse position. If the buzzer fails to sound, have it repaired. Make sure the lamps turn on and off properly. Burned-out bulbs must be replaced with new ones.

⚠ Keep your hands clean

It is dangerous to operate the steering wheel and levers with greasy hands. If grease, oil or soil is sticking to your hands, clean it off.

TRAVELING

⚠ Mount properly

Never mount or dismount a moving truck. When mounting or dismounting the truck, use proper procedures, make sure the truck is at a complete stop. Support your body using the steps and hand grips properly. Keep the steps always clean.

⚠ Do not move controls unless properly seated



Do not operate the controls (levers and pedals) unless you are properly seated.

⚠ Sound horn when starting



Before starting, make sure no one is near the truck. Let other workmen and bystanders know you are starting up by sounding horn.

1-22

⚠ Do not shut off the engine during traveling (trucks with power steering and power brake)

If the engine stops during traveling, both the power steering unit and the power brake goes inoperative.

⚠ Engine braking is not available when the inching pedal is pressed. (T type)

When the inching pedal is pressed to the bottom, the brake is applied to the truck, but engine braking is not available because the clutch unit is disengaged.

⚠ Safe traveling



• Always look in the direction of travel

Always look in the direction of travel; failure to do so will lead to an accident. When passing an oncoming truck each other, slow down and use caution to have a safe distance. Moreover, maintain a safe distance from the truck ahead of you at all times.

• Observe speed limits

Observe the specified speed limits.

• Make sure there is no one or obstacle around the truck and in the direction of travel or turning

• Do not go past other trucks where vision is restricted

Do not go past other trucks at intersections, corners, narrow aisles and other locations where your vision is restricted.

• Slow down at corners

Slow down and sound horn at intersections and other locations where your vision is restricted.

• Come to a complete stop before crossing roads or at corners

⚠ Do not travel over a floor or ground surface covered with water

Do not travel over a floor or ground surface covered with water. Go round any pothole in the road.

⚠ Do not get into a soft ground area



⚠ Do not ride on obstacles (curb, railroad tracks, ditches)

If unavoidable, be careful.

⚠ Avoid running on a slippery surface

⚠ Know the load bearing capacity of the floor

Before entering a building or going into an elevator, make sure the floor is strong enough to withstand the weights of the truck and the loads.

⚠ When going into areas where there are limits in height and width, use the following cautions:

- Make sure there is enough height and width for the truck to pass.
- Do not put your hands and feet outside the truck.
- Make sure there is no one around the truck.
- Watch out for outdoor electric cables and other obstacles.

⚠ Rear steer, rear swing

When the truck is turned in forward driving, the rear of the truck swings outwards. Before turning, make sure there is enough clearance from the wall and other obstacles.

⚠ Brake the truck in good time

The truck takes a little longer to come to a stop on a slippery surface than on a usual surface. Brake the truck in good time. In addition, the stopping distance of the truck is longer on a downhill. Keep the traveling speed under your control.

⚠ Practice safe driving and load handling techniques

Before using the lift truck, you must practice safe driving and load handling techniques. Even after getting familiar with the operation of the truck, operate the truck carefully; reckless driving and operation will cause a personal injury or an accident.

⚠ When using multiple trucks

When operating multiple trucks, remember that their operating controls have their own characteristics even if the trucks are of the same specification. If you change the trucks, keep this point in mind. In particular, pay attention to the brake system.

LOAD HANDLING

⚠ WARNING

- **Never overload**
Know the rated capacity of your lift truck and its attachment, if any, and never exceed it; otherwise the rear wheels will be raised, thus making it difficult to travel and turn. There is also danger of the truck tipping over.
- **Never lift a load over anyone**
Never permit anyone to stand under raised forks. The forks might fall down unexpectedly, thus causing a personal injury.
- **Never elevate a man**
Never allow other person(s) to ride on the forks. He might fall off the forks, getting injured.
- **Do not put your hands or feet into the load handling system**
Never put your hands or feet on the mast or mast connecting members; otherwise your hands or feet might be cut if the mast moves unexpectedly.



⚠ Do not lift off-centered loads

Make sure that the loads are evenly positioned across the forks and that the load's center of gravity is aligned with the truck's center of gravity. Off-centered loads might cause the truck to turn over.

⚠ Make loads in contact with load backrest

Insert the forks into the pallet as far as possible to make the loads in contact with the load backrest.

⚠ Do not lift unstable loads

Do not handle unstable loads. When handling loose loads, make sure they are stable enough before lifting.

⚠ Use due caution when handling loads

When handling loads, fix them with ropes or others, to prevent from falling off.

⚠ Do not stack loads too high on forks

Do not stack loads on forks in such a way that the top of loads exceeds the load backrest height; otherwise, loads might fall on the part of the operator, and in the worst case lead to a serious injury or death.

LOAD HANDLING

⚠ Do not tilt the mast with loads high



Use minimum forward and reverse tilt when stacking and unstacking loads. Never tilt forward unless the load is over stack; otherwise the truck might tip over.

⚠ Do not lift or start with mast tilted forward

When the mast is tilted forward, do not perform the following operations: lifting the forks and starting and traveling the truck.

⚠ Do not stack or unstack loads on a sloping grade

⚠ Keep the chains tight

A slack chain means a mast rail or carriage hang-up, which might cause the sudden fall of loads or carriage or the truck to tip over. Keep the lift chains stretched tight at all time.

⚠ Do not use your truck for purposes other than specified

- Do not use the truck to open or close the doors of freight cars or warehouses.

- Do not push other trucks.
- Do not hoist loads, using ropes hung on the forks.
- Do not tow another vehicle using the draw bar.
- Do not push or pull loads with forks; otherwise, the load might fall off or get damaged. In particular, the truck with the max. lift height of more than 150 cm(59 in) might tip over, if you try to do that.

⚠ Adjust fork spacing properly

Adjust the fork spacing suitable according to the size of the load.

⚠ Adjust fork spacing with your feet



Adjust the fork spacing with your feet. Do not use your hands. Your hands might get pinched between the forks and carriage.

⚠ Make sure forks are securely locked

After adjusting the fork spacing, lock the forks with fork stoppers. Unlocked forks will slide during traveling, causing the load to fall off.

LOAD HANDLING

Keep the tension of the right and left chains even

Uneven tension of the right and left chains means uneven loads even if they are properly placed on the forks. It may also lead to broken chains.

Pay attention to the fork tips

The fork tips are sharp and could cause personal injury. In addition, if they catch on obstructions, the truck might lose control, leading to an accident.

Keep anyone but a guide away from the working area

Do not let other persons or truck approach your lift truck during operation

When working in a group, have a person present to give guidance and follow his instructions

Use pallets and skids strong enough

Pallets and skids must be strong enough to withstand the weight of loads. Use of a damaged pallet or skid might let the load fall off the forks.

Use extreme caution when handling long or bulky loads

Lift and lower the load carefully so as not to hit it against something around the truck. Keep the load as low as possible. Be careful when turning the truck, to prevent it from moving out of position or falling off.

Be alert for overhead hazards

Use caution not to let the mast or overhead guard contact overhead power cables, piping, sprinklers or overhead exposed beams. If part of the truck comes in contact with them, the load might fall off the forks or the truck tip over. Remember that the mast height becomes higher when the forks are raised.

Do not pick up loads from other truck

Do not pick up loads from raised forks of other truck. This might cause an off-centered load or the load to fall off.

Do not hold loads on the forks by hand

Do not hold loads on the forks by hand. If the truck moves unexpectedly, the load might fall off, getting the person caught under it.

Do not squeeze loads into the stack

Do not squeeze loads into the stack using the truck's traction force. This will cause damage to the truck or loads, causing the truck to tip over.

⚠ Do not hang loads with wire ropes attached directly on the forks

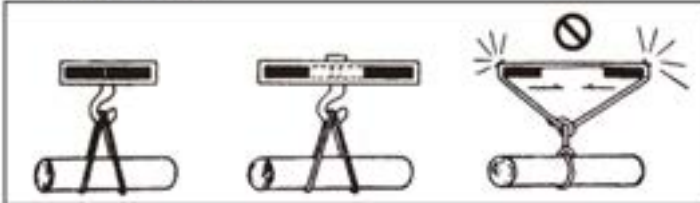

- Do not hang loads with wire ropes attached directly on the forks or attachment. If the wire ropes break or slide off, a personal injury might result. In particular, the use of a wire rope hung on one of the forks might cause the truck to turn over.
- Use a hook attachment or crane arm attachment to hang loads.
- Make sure that the wire ropes are strong enough to withstand the weight of the load and properly attached. The length of the ropes should be as short as possible but with adequate spread angle between legs.
- Carefully travel and turn when hanging a load with wire ropes; otherwise, if the load swings, the truck might turn over. Keep the load as low as possible.



PARKING

- ⚠ When leaving the truck, observe the following conditions:**

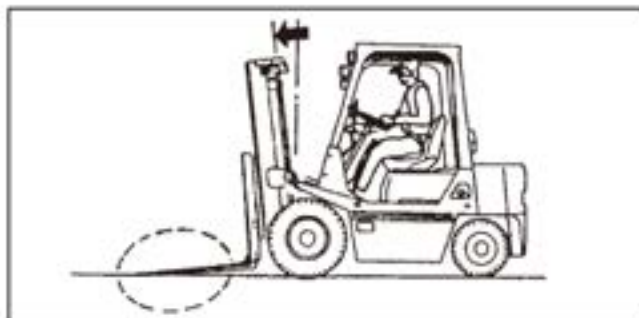

- Park the truck on an out-of-traffic area and lower the forks on the ground.
- Tilt the mast a little forward and make the fork tips in contact with the ground surface.
- Apply the parking brake.
- Place the shift levers (speed and direction) in neutral.
- Turn the key switch "OFF" to shut off the engine.
- Remove the key.

- ⚠ Park at the specified area**

- ⚠ Park on a hard surface**

- ⚠ Park at an out-of-traffic area**

Park at an out-of-traffic area. Avoid parking near emergency exits, stairs, or fire hydrants.

- ⚠ Do not park near flammables**

- ⚠ Block the wheels when parking on a slope**

If unavoidable to park on a slope, apply the parking brake securely and block the wheels.

- ⚠ When parking a faulty truck**

When it is not possible to lower the forks on the ground due to a faulty load handling mechanism, attach a sign to the tip of the forks to prevent pedestrians and other vehicles from bumping against the forks. Park the truck at an out-of-traffic area and take measures so as not to let people pass under the raised forks.

- ⚠ Remove the key from a faulty truck and put up a sign**

Remove the starter key and attach a sign saying DO NOT OPERATE.

- ⚠ Do not ride on front guard**



It is dangerous to use the truck body or mast as a ladder to ride on a high place.

You might be caught between the mast and truck body, resulting in a serious accident.

INSPECTION AND SERVICE

⚠ WARNING

Inspection and maintenance of the truck should be performed only by qualified and authorized personnel. Improper inspection, maintenance or repairs will cause damage to the truck or a serious accident.

⚠ Park on a hard, level ground

Before performing inspection and maintenance, make sure to park the truck on a hard, level surface. Also make sure the place is dry and without dust.

⚠ Have a good ventilation

When performing inspection and maintenance indoors, have a good ventilation.

⚠ Have a fire prevention equipment handy

Have a fire prevention equipment handy whenever working indoors. Know how to use it.

⚠ Make sure the forks and other attachment (if any) are on the ground

⚠ Before starting inspection shut off the engine

Make sure the engine is shut off before trying to start inspection or maintenance.

⚠ Unless otherwise specified, shut off the engine

Unless otherwise specified, inspection or maintenance should be performed with the engine shut off.

⚠ Before starting inspection or maintenance, place the control levers in neutral

Make sure the shift lever(s) and load handling levers are in neutral before starting inspection or maintenance.

⚠ Wipe any spilt oil or grease

Wipe any spilt oil or grease. If the truck is contaminated with oil or grease, it is difficult for you to find possible cracks or other defects.

⚠ No fire (when handling lubricants, batteries, cloth wetted with oil)

No fire. Never smoke or use fire or naked flame when handling lubricants, batteries or cloth wetted with oil.

⚠ Avoid loose fitting clothing

Wear protective clothing called for by job conditions.

⚠ Wear safety gear devices (hard hat, safety shoes, safety glasses, gloves)

⚠ Use caution not to fall down from the truck when working on the truck

⚠ Do not put your feet under the forks

⚠ Use caution not to get your fingers pinched in the floor plates or hood

Be careful so as not to get your fingers caught when closing the battery cover or doors.

INSPECTION AND SERVICE

⚠ If unavoidable to work under raised forks or attachment, use a stable support under the inner mast and/or the carriage to prevent the forks or attachment from falling down unexpectedly

⚠ When working in a group, have a leader and follow his instructions

⚠ Use appropriate tools

Use appropriate tools suitable for the job you have been assigned. Use of inappropriate tools might cause a serious accident.

⚠ Do not use tools for purposes other than specified

Do not use tools for purposes other than specified. It can cause a serious accident.

⚠ Do not remove radiator cap when the cooling water temperature is high



Immediately after the engine is shut down, the cooling water is hot and in high pressure.

Do not try to remove the radiator cap in this state. Hot cooling water might spout out to cause a serious personal injury or burns.

⚠ Loosen radiator cap slowly to allow steam to escape

⚠ Make sure the engine is cool enough before servicing it

Immediately after the engine is shut down, the engine oil is hot and in high pressure. Do not try to drain oil or replace the filter. Hot engine oil might spout out to cause burns.

⚠ Hydraulic oil is hot immediately after the engine is shut down

Immediately after the engine is shut down, the hydraulic oil is hot and in high pressure. Do not try to drain the hydraulic oil or replace the filter. Hot oil might spout out to cause burns.

⚠ Release oil pressure before working

The hydraulic circuit has residual pressure. Before working on the system, release the pressure. To check for oil leaks, wear safety glasses and gloves and use a piece of cardboard or wood. High pressure oil penetrates the skin. It can cause blindness.

⚠ Checking of accumulator and piping is hazardous

Inspection of piping where an accumulator is installed is hazardous. When it needs to be inspected, ask your dealer.

⚠ When high pressure oil comes in contact with your body, immediately get medical attention

INSPECTION AND SERVICE

- ⚠ **Shut down the engine before working on rotating parts**



Use due caution when working on rotating parts, not to get your body or fingers entangled in them. Before checking a rotating part, make sure the engine is shut down. Do not bring something near rotating parts.

- ⚠ **Do not use the mast as a ladder**

- When carrying out checks or adjustment, do not use the connecting member or load backrest as a ladder. The mast might move unexpectedly, pinching or cutting your hands or feet.
- Do not use the mast as a ladder. You might fall down from the mast, leading to a serious accident.

- ⚠ **Caution to be taken when adjusting tire inflation pressure (rim, compressor)**



- When checking tire inflation pressure, position yourself in the path of rotation, not on the side of the tire.
- When inflating a tire using a compressor, first adjust the air pressure of the compressor; otherwise the air pressure will rise to the maximum pressure of the compressor, leading to a serious accident.
- Inflating tires to a high pressure requires special skill. Inflating tires requires special skill. Tires must be inflated only by a qualified person.
- When using compressed air, wear safety glasses and mask. When inflating tires, wear safety glasses and mask because dust might get into your eyes or mouth.

- ⚠ **Leave the disassembly and reassembly of tires, tubes and rims to a specialist**

The inflation pressure of tires of the lift truck is very high (about 700 -1,000 kPa) and thus due caution must be required to disassemble or reassemble the tires. An improperly reassembled tire might cause explosion to let parts fly into pieces, resulting in a serious personal injury.

INSPECTION AND SERVICE

Do not loosen the wheel assembly nuts when changing a tire (see the sketch on page 4-24)

The wheel assembly is locked in two ways: Hub nut type and nut type. In the hub nut type wheel assembly, the wheel is installed to the hub; in the nut type, a wedge ring is inserted between the wheel and the hub to lock the wheel assembly.

The tire is secured with the side ring and the lock ring.

When removing a tire from the truck, make sure the lock ring is securely installed; otherwise, the side ring, tire, and wedge ring might burst out, resulting in a severe accident.

Do not loosen bolts and nuts of split rim assembly

- The wheel has hub nuts that secure the wheel to the hub and rim nuts and bolts that assemble two rims together.

When removing a tire from the truck, do not loosen the bolts and nuts of the split rim assembly.

If the bolts and nuts of the split rim assembly are removed, the rims, bolts or nuts might blow off due to the internal pressure of the tire, to cause a serious personal injury.

- When replacing the rim assembly, install a new rim assembly with the head of each of the dowel bolts of the rim assembly pointing outside. (This helps make it difficult to loosen the rim bolts with the tire attached to the truck. Some bolts have a special shape for this purpose.)
- After replacing tires, test run the truck to check to see if the hub nuts are securely tightened. If a loose hub nut is found, tighten it to the specified torque.

WARNING

Cautions to be taken when using the jack
Do not enter under the truck while it is jacked up. The truck might fall, getting you caught under it.

- Before jacking up the truck, remove the loads from the truck.
- When jacking up the truck, the operator must leave the truck.
- Lift the truck a little off the ground surface and put supports at both sides of the frame to prevent the truck from falling.
- Before jacking up, block the wheels to prevent them from rotating unexpectedly.
- Lifting the truck must be performed only by qualified personnel (for crane or slinging work).
- The truck must be lifted by attaching wire ropes to the designated parts.
- Use strong wire ropes.
Make sure the wire ropes are strong enough to lift the truck and free from damage.

Cautions to be taken when handling batteries

- **If electrolyte gets on your skin, flush it off with a copious amount of water**
The battery electrolyte contains dilute sulfuric acid, a very corrosive material. It can destroy most things it touches. It will cause painful and serious burns if it gets on the skin. It can cause blindness if it gets into eyes. If battery electrolyte comes in contact with the skin or clothing, wash it away immediately with a copious amount of water.
- **If electrolyte gets into your eyes, get medical attention**
If electrolyte gets into your eyes, flush it off immediately with a copious amount of water and get medical attention.

INSPECTION AND SERVICE

- **Wear safety glasses when handling batteries**

Wear rubber gloves, rubber boots, safety glasses when changing or charging batteries, adding battery electrolyte, or adjusting the specific gravity of the battery electrolyte.

- **If anyone swallowed electrolyte accidentally :**

Let him drink a copious amount of water or milk with egg white and salad oil mixed in it and take a rest. Send for a doctor.

- **No fire**

Since explosive hydrogen gases are always being released from the battery, there is a danger of causing an explosion. Never smoke or use fire or naked flame near the battery. No sparks. To prevent the generation of sparks, turn off the charger switch before connecting or disconnecting the battery or charger cable.

- **Do not short both poles for checking the battery,s state of charge**

- **Remove the negative (-) terminal of the battery first and reinstall it last (Engine trucks)**

When removing the battery, disconnect the negative (-) terminal first. When reinstalling, connect the positive (+) terminal first, and then connect the negative (-) terminal.

- **Do not connect or disconnect the battery receptacles with the battery circuit conducting (Electric trucks)**

- **Do not put any metal tool on the battery case**

- **Do not short the battery terminals**

Do not short the battery terminals by placing a piece of metal between the positive and negative terminals. A loose terminal might cause sparks, causing an explosion. Make sure the terminals are tight. Use caution not to have the wrong connections of the battery terminals.

- **When turning the screw of the positive pole of the battery, use caution not to allow the tool to touch the metal parts of the truck, such as the engine (Engine trucks)**

If the tool touches metal parts, there might occur sparks,

causing an accident.

- **Pay attention to battery electrolyte level**

Do not operate the truck or charge the battery when the battery electrolyte level is below the LOWER LEVEL marking; otherwise, the components inside the battery may be deteriorated and the battery life shortened, and in the worst case an explosion might occur. Keep the battery electrolyte level between the UPPER LEVEL and LOWER LEVEL markings at all times. Add purified water if the level is low.

- **When cleaning the battery, make sure the battery caps are securely tightened**

- **Have a good ventilation when charging**

Since hydrogen gases are released from the battery during charging. Have a good ventilation; otherwise an explosion might result. Keep the battery case cover open.

- **When charging the battery, follow the instructions in the instruction Manual of the charger**

- **No fire during charging**

Batteries give off hydrogen gases during charging. No fire. No sparks.

- **Make sure the battery electrolyte temperature is below 35°C**

Hydrogen gases are released from the battery during charging, causing the battery to heat. Before trying to charge the battery, make sure the battery electrolyte temperature is below 35°C . (If the electrolyte temperature reaches 50°C or more, discontinue charging and wait until the electrolyte temperature drops to 35°C or lower.)

- **The truck batteries are high voltage**

The batteries used for electric trucks are high voltages more than 48V. If anyone touches it inadvertently, he can get an electrical shock accident or burn.

- **Static electricity is hazardous**

Static electricity is generated when cleaning the top surface

CAUTION PLATES

The caution plates attached to the lift truck explain cautions to be taken when using the truck, and procedures for operating the truck. Read messages on the caution plates as well as the description in this manual. Damaged or missing decals must be replaced with new ones.

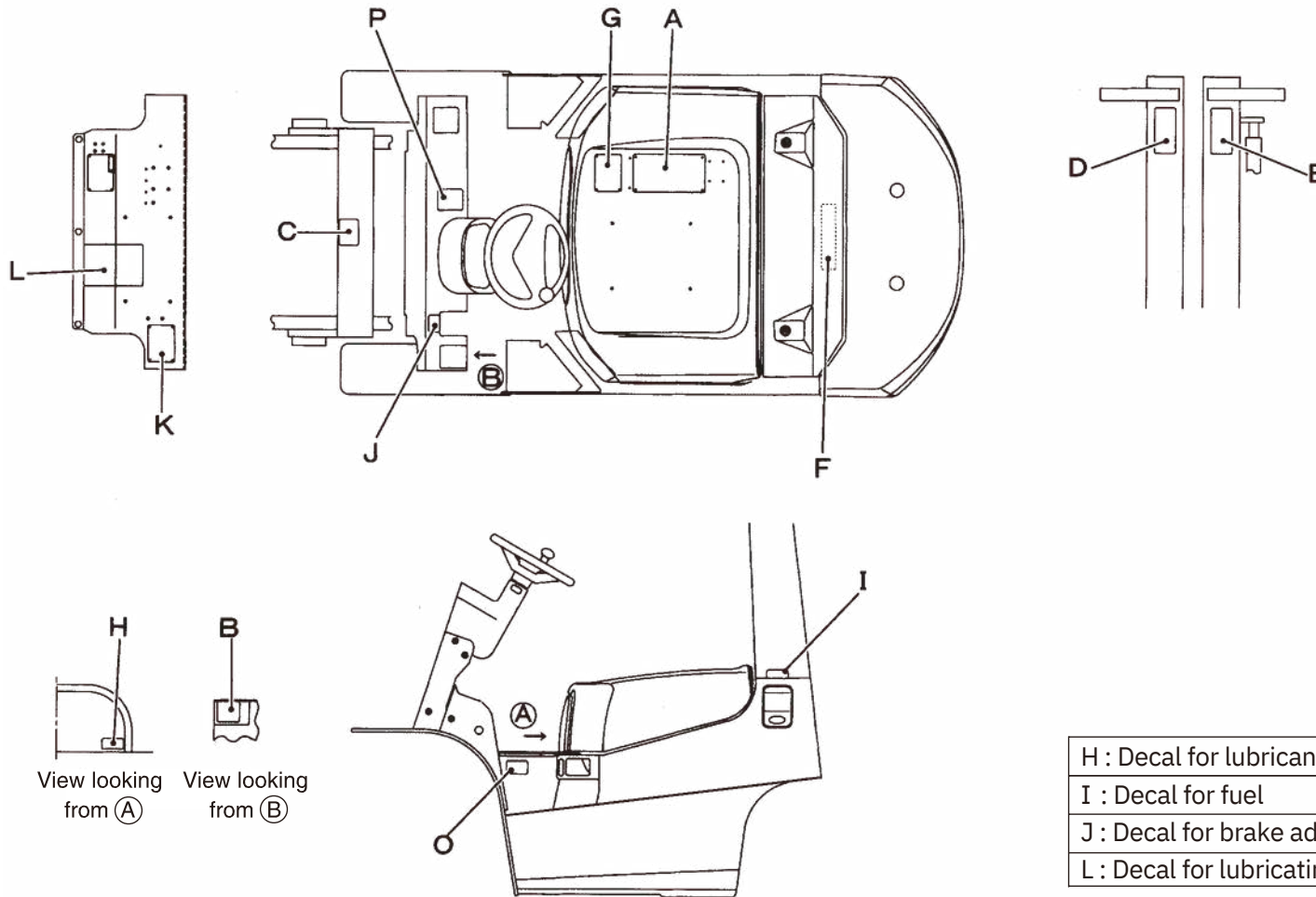

CAUTION PLATES

A. Safe operation

 CAUTION
<p>YOU MUST FOLLOW THESE RULES TO AVOID SEVERE INJURY OR DEATH TO YOURSELF AND OTHERS.</p> <ol style="list-style-type: none"> 1. Operate truck only if trained and authorized by your employer. Know Operation & Maintenance Manual and all work rules. 2. Safety check truck every day. Do not start if damaged or faulty; stop if problems start. Repair allowed only by trained, authorized mechanics. 3. Turn, start, stop, and handle loads smoothly and slowly. Carry loads low and tilted back; stack only on level using minimum tilt. 4. Look where you are going. Watch out for people, hazards on floors and overhead, drop-offs and tail swing clearance. 5. Truck overturn can kill you. Slow for turns even when empty. Never turn on inclines. 6. Do not lift overweight or loose loads. Move slowly with wide, high, or long loads. Keep forks wide and fully under loads. Travel in reverse if loads block view. Attachments require special training, ask your employer. 7. Keep loads upgrade on all inclines. Stay clear of ramp and dock edges. Make sure dockboards and trailers are secure before going on them. 8. Overhead guard and load backrest must be on truck. Always keep yourself completely inside guard. Stop engine when refueling. Follow Operation & Maintenance Manual and employer®, work rules about fuel, battery and tire maintenance hazards. Forks can fall rapidly even with light loads. 9. Do not raise people or allow them under forks. No passengers allowed on truck. Park only in authorized areas, never on inclines. 10. Lower forks to bottom, put direction control in neutral, turn off key and make sure parking brake is set. 11. Fasten the seat belt, when operating the lift truck.

B. Warning decal for handling inflated tires

 WARNING

<p>AVOID SEVERE INJURY OR DEATH. Tire servicing requires special training. Do not take tires off truck until all air pressure is out. Loosen only WHEEL LUG NUTS. Do not loosen wheel assembly nuts until all air pressure is out of tire. See OPERATORS MANUAL for more important instructions for wheel service and reassembly. Make sure all nuts and bolts are in place and tight. Never add air to a tire that looks low. Let all air out and check for proper assembly. Inflate all tires in a safety cage. See MANUAL for proper pressures.</p>
<div style="text-align: center;">  Spill-type </div> <div style="text-align: center;">  Safety cage </div>

C. Warning decal for mast connecting member

	
WARNING	

D. Warning decal for load handling means

 WARNING	
	<p>Do not let riders on forks or pallet.</p>
	

F. Warning decal for fan and other rotating parts

 WARNING	<p>Use caution not to get entangled while the engine running.</p>
	

CAUTION PLATES

P.Load chart: Decal for overloading

K.Name plate

P.Warning decal for front guard O.Decal for tire inflation pressure

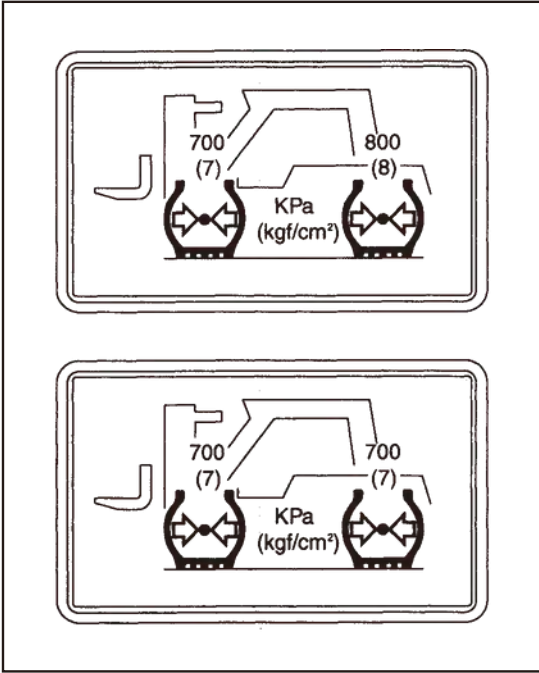
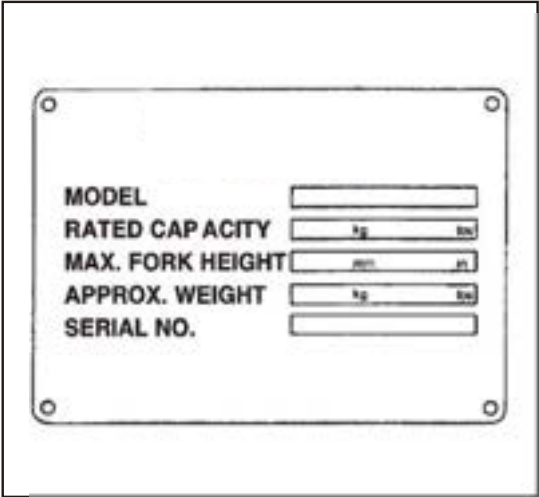

CAUTION PLATES







■ Caution plate for handling batteries

■ WARNING

If the battery is used or charged when the electrolyte level is below the LOWER LEVEL mark, the battery may be damaged. It may also reduce the battery life or cause an explosion. Add electrolyte so that the level is between the UPPER LEVEL and LOWER LEVEL marks.

⚠ WARNING

Hydrogen gas produced by a battery can explode. Keep all open flames and sparks away from the battery. To prevent sparks, when connecting or disconnecting the battery or charger cables, be sure to stop the engine or turn off the charger switch.

						
No fire	Wear safety glasses	Keep children away	Sulfuric acid	Read manual	Explosive	Electric shock

 **DANGER**

- Handle the battery carefully; otherwise you will get injured.
- Pay attention to an open flame or static electricity which might cause an explosion or a fire.
- Sulfuric acid will cause painful and serious burns if it gets on the skin. It can cause blindness if it gets into eyes.
- Touching a conducting part with bare hands will cause an electric shock accident.
- Do not connect or disconnect the battery plugs during the battery turned ON; otherwise you might get burnt or an explosion might occur.





- No fire. Do not smoke. Keep sparks or flames away from batteries.
- Static electricity: Do not clean batteries with a duster or dry cloth.
- Ventilation: Get a good ventilation. Do not use or charge batteries in a closed place or an area where ventilation is poor.
- Sulfuric acid: If sulfuric acid comes in contact with you skin or clothing, wash it away using a copious amount of water immediately. If sulfuric acid gets into your eyes, wash your eyes with a copious amount of water immediately and get to a doctor.
- Electrolyte level: Keep the battery electrolyte level proper at all times. If the level is too low, the battery will build up heat or the level is too high, electric leakage will occur.
- Electric shock accident: Wear safety glasses, rubber gloves, and shoes with rubber soles when servicing or inspecting batteries.

NOTE

A series of horizontal dashed lines for writing notes.

The following symbols, found throughout this manual, alert you to potentially hazardous conditions to the owner and the operator. Become completely familiar with the truck before proceeding with operating, checking and servicing.

This manual and decals affixed to the truck use the following safety alert indications.

SIGNAL WORD	CLASSIFICATION
 DANGER	Failure to follow the instructions in the message will likely cause a serious accident or death .
 WARNING	Failure to follow the instructions in the message might cause a serious accident or death.
 CAUTION	Failure to follow the instructions in the message may cause personal injury or damage to the truck or other property .
 NOTE	The information will help to prolong the service life of the truck The message is not directly related to accident prevention .

2. OPERATING CONTROLS

CONTENTS

PICTORIAL NOMENCLATURE.....	2- 2
INSTRUMENTS AND CONTROLS.....	2- 4
SWITCHES.....	2- 6
METERS AND WARNING LIGHTS.....	2- 8
LEVERS AND PEDALS.....	2-11
TRUCK BODY AND OTHERS.....	2-15

PICTORIAL NOMENCLATURE

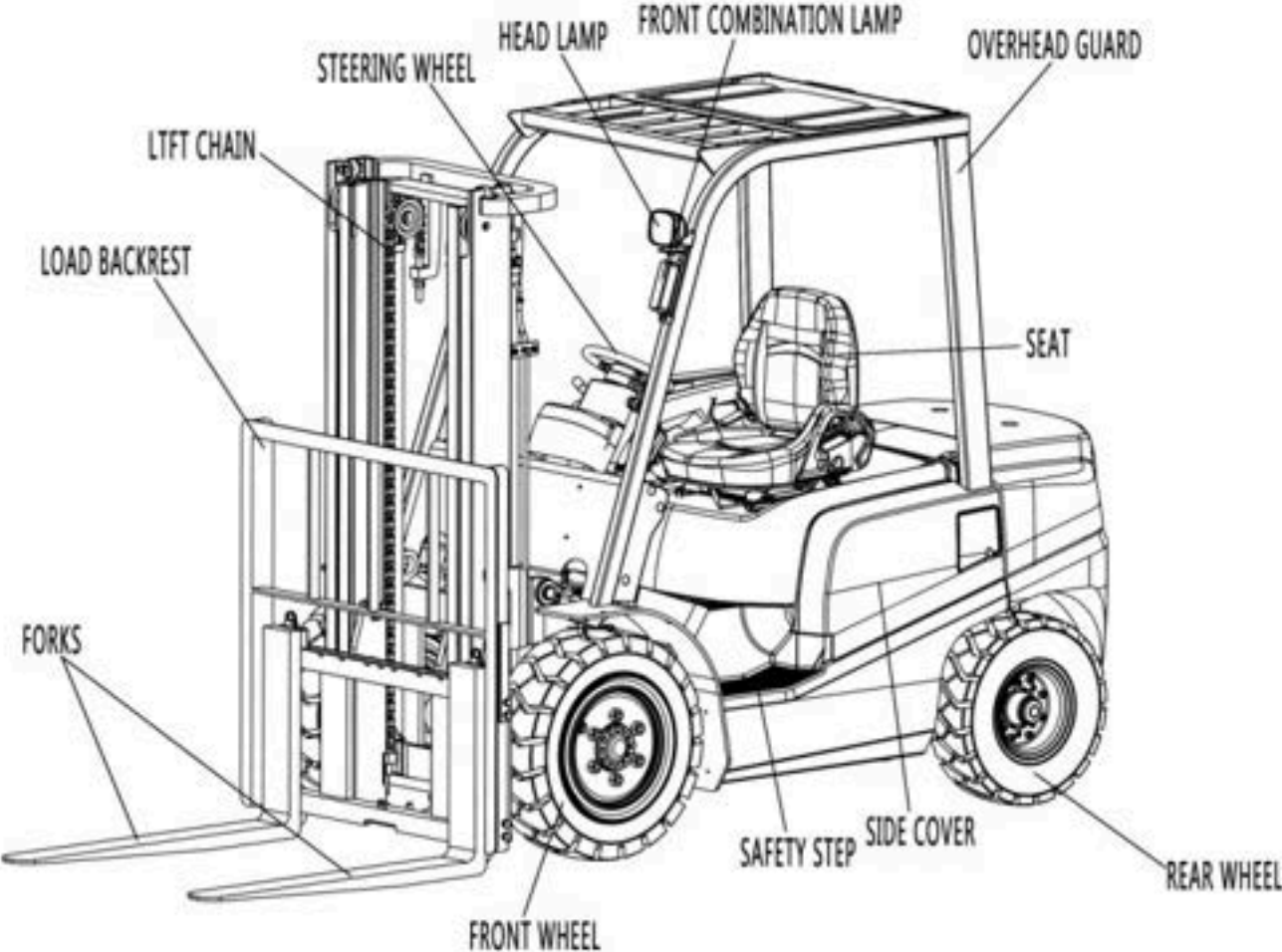

PICTORIAL NOMENCLATURE

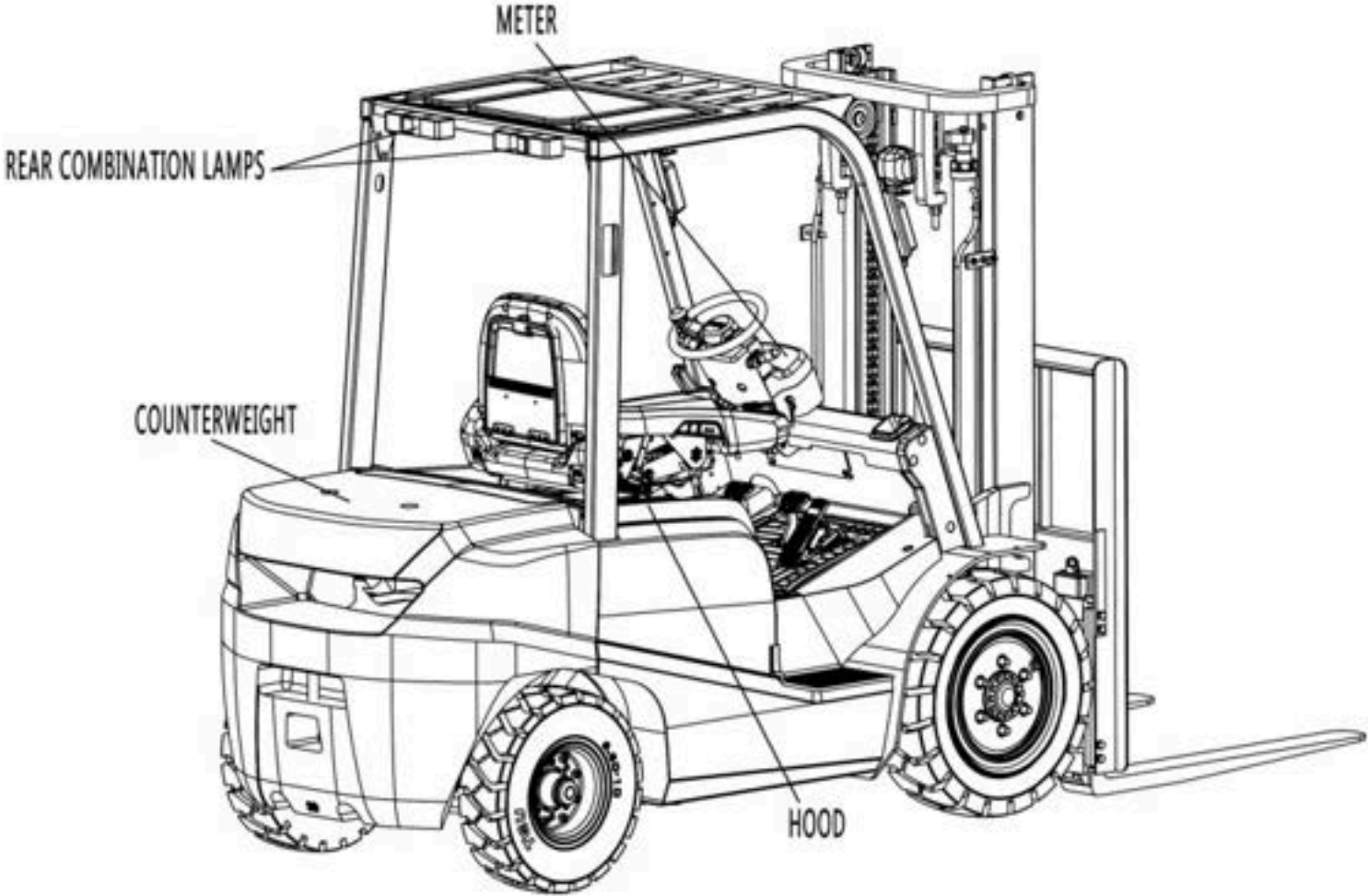

INSTRUMENTS AND CONTROLS

SWITCHES

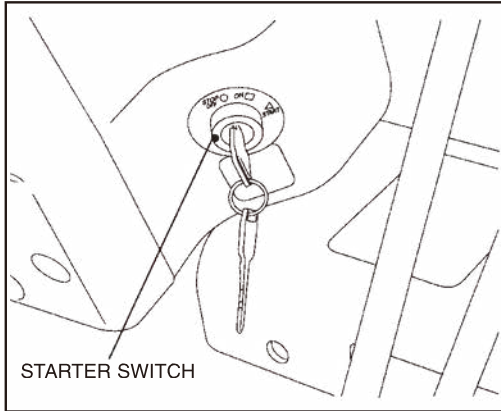

STARTER SWITCH

OFF STOP

The position at which the key is inserted or drawn out.

The starter switch is "OFF" at this position. The engine stops when the starter switch is turned to this position.

ON

The electric circuit for the starter motor and others is closed.

On the diesel engine truck, the glow indicator will come on when the key switch is turned to "ON" After the glow indicator goes out, turn the starter switch

2-4

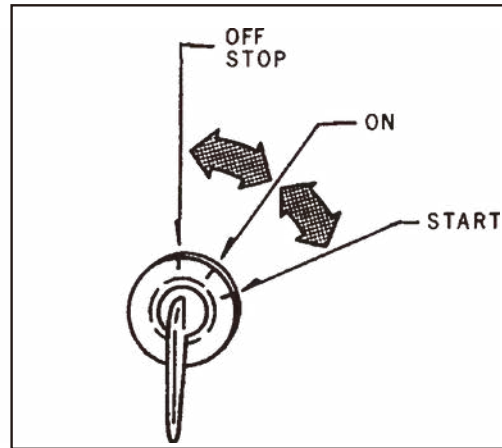

to the "START" position. While the engine is running, keep the key switch at the "ON" position.

START

The engine starts. After the engine starts up, remove your hand from the key. The key switch will automatically return to the "ON" position.

NOTE

- Do not keep the key switch in the "ON" position while the engine is not running. This will cause a discharged battery. While the engine is running, keep the key switch in the "ON" position.

- While the engine is running, do not turn the key switch to the "START" position. It will cause a damaged starter motor.
- Do not keep the starter motor turning for more than 10 seconds at a time. If the engine "won't" start, wait about 20 seconds before trying again.
- The engine "won't" start up unless the direction and speed range shift levers are in neutral "N" (T type)
- The engine "won't" start up unless the direction shift lever is in neutral "N" (C type)
- For the automatic choke, see page 3-5. (Gasoline engine trucks)

INSTRUMENTS AND CONTROLS

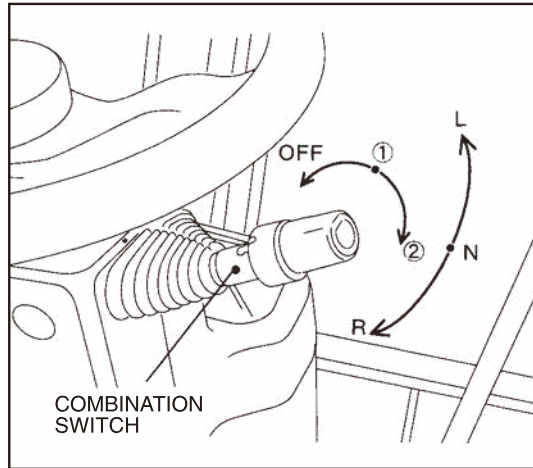

COMBINATION SWITCH (LIGHTING) (TURN SIGNAL)

This light switch can be pulled out in 2 steps.

Light	Stage		
	OFF	①	②
Clearance light	OFF	ON	ON
Tail light	OFF	ON	ON
Meter panel	OFF	ON	ON
Head light	OFF	OFF	ON

NOTE

The above lights turn on or off regardless of the starter switch. Remember to turn them off when leaving the truck.

Use the turn signals (front and rear) to indicate the traveling direction of the truck.

L	Left lights turn on.
N	OFF
R	Right lights turn on.

NOTE

The turn signal lever automatically returns to neutral when the steering wheel is returned to the straight position.

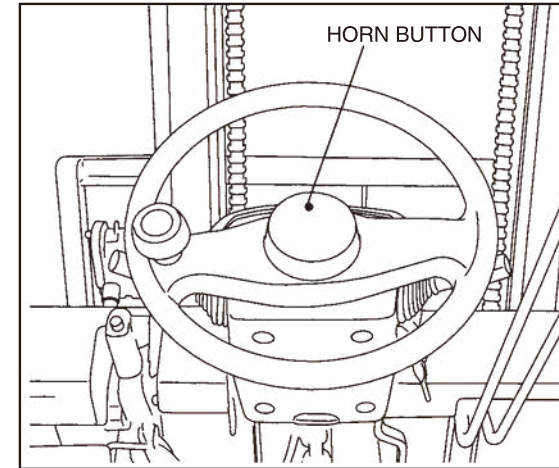

HORN BUTTON

Press the horn button at the center of the steering wheel to sound the horn. The horn sounds regardless of the starter switch position.

INSTRUMENTS AND CONTROLS

METERS AND WARNING LIGHTS

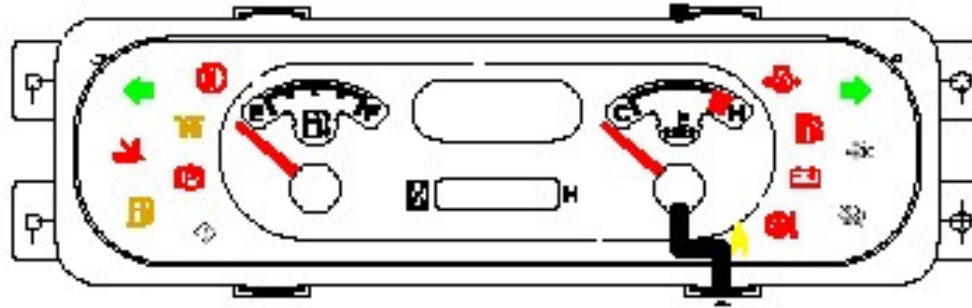

COMBINATION METER

The meter panel contains meters and monitors. Use them to check the operating status of the truck.

FUEL GAUGE

The fuel gauge indicates the fuel level in the fuel tank.

NOTE

- When checking the fuel level, park the truck on a level surface; otherwise you cannot get the correct fuel level.
- Add fuel before the fuel level drops to the minimum, to avoid the entrance of air into the fuel system.

ENGINE WATER TEMP. GAUGE

This gauge indicates the temperature of the engine cooling water. Under the normal operating condition, the pointer stays in the "white" range. If the point enters the "H" (red) range, it suggests that the engine is overheating. Park the truck at an out-of-traffic area and let the engine run at idle rpm until the pointer returns to the "white" range.

NOTE

- Do not shut off the engine even if the pointer enters the "red" range; otherwise the engine might cause malfunction.
- For the procedure for remedying an overheated engine, see page 3-14.

HOUR METER

The hour meter operates only while the starter switch is "ON" and records total operating time of the truck in hours and tenth of an hour (6 minutes). Use it to determine maintenance schedule.

GLOW INDICATOR LAMP

Diesel engine truck

When the key switch is turned to "ON" the engine is preheated with the glow indicator coming on.

The glow indicator goes out in about 3.5 seconds after the key switch is turned to "ON", indicating that the engine is ready for starting.

Note that the glow indicator will go out immediately when the engine cooling water temperature is more than 60°C (140°F).

INSTRUMENTS AND CONTROLS

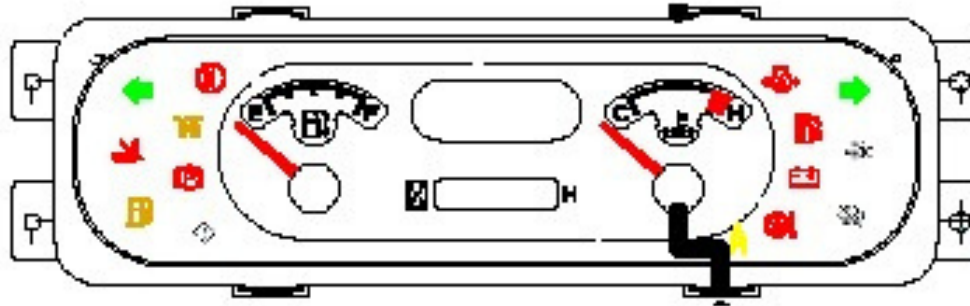

SEDIMENTER WARNING LIGHT

Diesel engine truck

Light comes on when the water level in the sedimenter exceeds the specified value. The fuel injection pump lubricates inside the engine using fuel. For this reason, the water content in the fuel is removed using the sedimenter. If light comes on during operation, stop the operation immediately and drain water.

⚠ CAUTION

- If the truck is used neglecting the warning light, the fuel injection pump might be seized. For the
- procedure for draining water from the sedimenter, see page

CHARGE WARNING LIGHT

Light comes on when the power generating system fails to operate normally. This warning light comes on when the starter switch is turned to "ON" and goes out when the engine starts up. If light does not go out after the engine starts up, it suggests that the fan belt is loose or broken, or that the power generating system is defective. Stop the operation immediately and troubleshoot.

ENGINE OIL PRESS. WARNING LIGHT

Light comes on when the engine oil pressure drops.

Light also comes on when the starter switch is turned to "ON" and goes out when the engine speed is increased by pressing the accelerator pedal after cranking the engine. If light comes on during operation, it suggests that the engine oil level is low or the lubricating system is defective. Stop the operation immediately and troubleshoot.

INSTRUMENTS AND CONTROLS

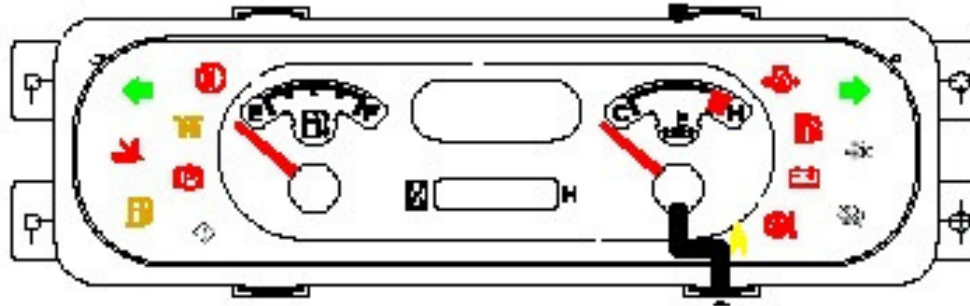

AIR CLEANER CLOGGING WARNING LIGHT

Light comes on when the air cleaner becomes clogged. If light comes on during operation, stop the engine immediately and clean the element and dust cup.

PARKING BRAKE INDICATOR

Light comes on when the parking brake is applied and goes out when the parking brake is released.

FUEL LEVEL WARNING LIGHT

Light comes on when the fuel level in the fuel tank drops below the specified value.

BATTERY ELECTROLYTE LEVEL WARNING LIGHT

Light comes on when the electrolyte level drops below the LOWER LEVEL. If light comes on, add purified water for battery up to the UPPER LEVEL.

RADIATOR WATER WARNING LIGHT

Light comes on when the cooling water in the radiator reservoir tank drops below the lower limit. If light comes on, add cooling water up to the upper limit of the reservoir tank.

TORQUE CONVERTER OIL TEMP. GAUGE

The gauge indicates the temperature of the torque converter oil.

NOTE

If the pointer enters the red range, stop the truck and check the torque converter oil level and piping for leaks. If the oil level is proper and no oil leaks are found, consult your local dealer.

INSTRUMENTS AND CONTROLS





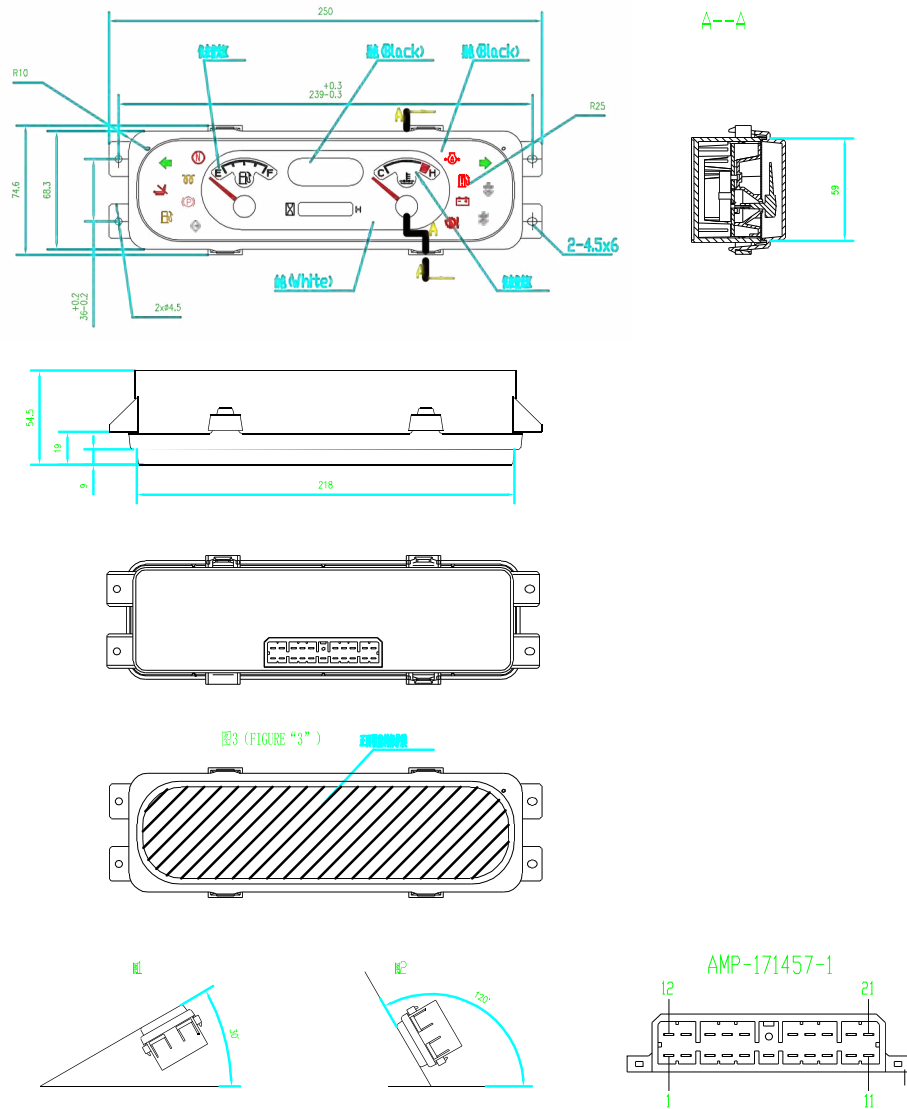









Switch introduction			
	Name	Function	Remark
	DPF regeneration request switch	When the DPF regeneration reminder light is on or flashing slowly, and the parking regeneration conditions are met, press the DPF regeneration request switch to start the parking regeneration	When parking regeneration is required, the vehicle must be stable and unable to work, the gear is in neutral, pull up the handbrake, press the DPF regeneration request switch to start parking regeneration
	DPF regeneration suppression switch	Press to prohibit driving regeneration	

INSTRUMENTS AND CONTROLS













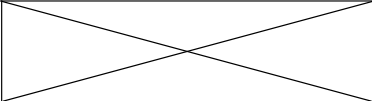

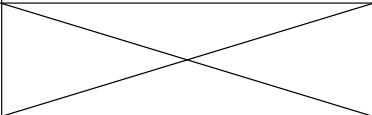

INSTRUMENTS AND CONTROLS

Technical parameters of switching quantity:

Item name	Alarm lamp and color	Alarm indication level		Input signal level in normal state	Input signal level in alarm state	Picture	Remarks
Low engine oil pressure	LED and red	Normally on	Buzzer	Suspended	0V (grounding)		
Charging indication	LED and red	Normally on	No buzzer	12V (24V)	0V (grounding)		
Oil-water separation	LED and red	Normally on	Buzzer	Suspended	0V (grounding)		
Preheating indication	LED and yellow	Normally on	No buzzer	Suspended	0V (grounding)		
Left turn	LED and green	Normally on	No buzzer	Suspended	12V (24V)		
Right turn	LED and green	Normally on	No buzzer	Suspended	12V (24V)		
Low oil level indication	LED and yellow	Normally on	Buzzer	Send alarm when the level is lower than 1/16, corresponding sensor resistance value: $\leq 1 \Omega$			Analog signal
Neutral gear indication	LED and green	Normally on	No buzzer	Suspended	0V (grounding)		
High oil temperature of torque converter	LED and red	Normally on	Buzzer	Send alarm at 120°C, corresponding sensor resistance value: $\leq 60 \Omega$			Analog signal
Hand brake	LED and red	Normally on	No buzzer	Suspended	0V (grounding)		
Seat	LED and red	Normally on	No buzzer	Suspended	0V (grounding)		
Engine self-check	LED and red	Normally on	No buzzer	Suspended	0V (grounding)		
DPF regeneration	LED and yellow	Normally on	No buzzer	Suspended	0V (grounding)		
DPF regeneration inhibition	LED and yellow	Normally on	No buzzer	Suspended	0V (grounding)		

INSTRUMENTS AND CONTROLS

Definition of socket connector terminal:

7		14	Fuel sensor 	21	DPF regeneration inhibition (-) Yellow 
6	Power ground (-)	13	Engine self-check (-) Red 	20	Charging indication (-) 
5		12	Hand brake (-) 	19	Oil temperature sensor of torque converter 
4	Left turn (+) 	11	Oil-water separation (-) 	18	Water temperature (PWM signal)
3	Neutral gear (-) 	10	DPF regeneration (-) Yellow 	17	Power supply (+) (16 and 17 shall be connected to the power supply at the same time)
2	Seat (-) 	9	Low oil pressure (-) 	16	Power supply (+) (16 and 17 shall be connected to the power supply at the same time)
1	Preheating (-) 	8	Right turn (+) 	15	Instrument lighting (+)
Terminal code	Function	Terminal code	Function	Terminal code	Function

***Note: Pins 16 and 17 shall be connected to the power supply (positive pole) at the same time, so that the instrument can work normally.

INSTRUMENTS AND CONTROLS

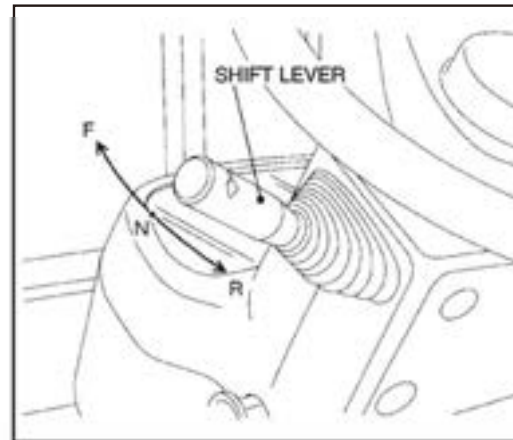

SHIFT LEVER (T TYPE)

The truck is equipped with a single shift lever on the steering column (1 speed for forward and reverse).

When the shift lever is placed in the reverse position "R" the back-up lamp comes on and the back-up buzzer sounds.

Bring the truck to a complete stop when reversing the direction of travel, from forward to reverse or vice versa.



NOTE

The direction shift lever (C type) and shift lever (T type) have a neutral switch. Before starting the engine, make sure the lever is in neutral. Neither the C- or T- type truck "won't" start if the direction shift lever (C type) or the shift lever (T type) is not in neutral.



CAUTION

Press the brake pedal to the floor before operating the shift lever.

The truck start moving slowly or creeps when the brake is released if the shift lever is in positions other than neutral.

Do not release the brake pedal until you are ready to start.

INSTRUMENTS AND CONTROLS

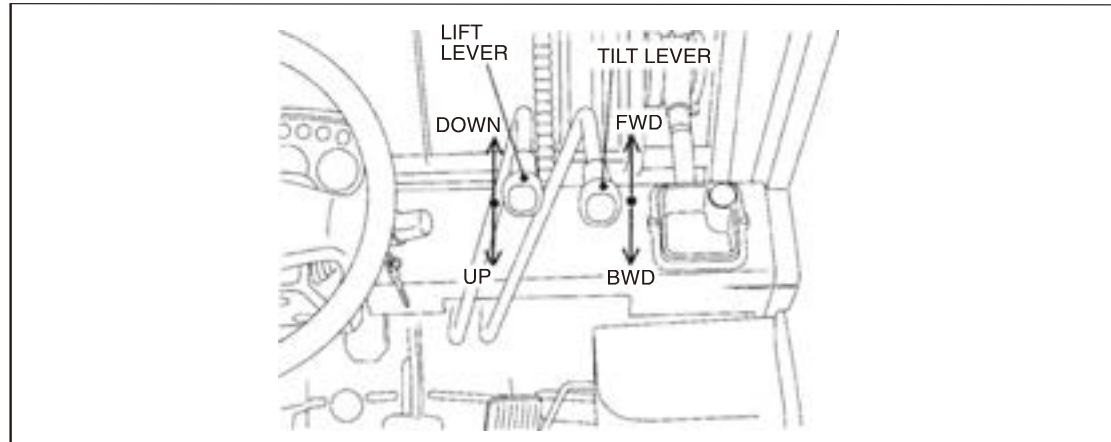

LIFT LEVER

CAUTION

Seat yourself in the driver's seat and make sure there is no one around the truck before operating the lift lever.

Pull back on the lever to raise the forks and push forward on it to lower the forks. The lifting speed of the forks can be controlled by the tilt angle of the lever and accelerator pedal effort or engine speed. Note that the lowering speed of the forks is controlled by the tilt angle of the lift lever alone. The engine speed has no connection with the lowering speed of the forks.

2-14

TILT LEVER

CAUTION

Seat yourself in the driver's seat and make sure there is no one around the truck before operating the tilt lever.

Pull back on the tilt lever to tilt back the mast and push forward on it to tilt the mast forward.

The tilting speed of the mast can be controlled by the tilt angle of the tilt lever and accelerator pedal effort or engine speed.

NOTE

When the engine is not running, the mast won't tilt forward even if the tilt lever is operated, because the tilt-lock mechanism installed in the control valve operates.

Note that the forks drop when the lift lever is pushed forward, even when the engine is not running.

INSTRUMENTS AND CONTROLS

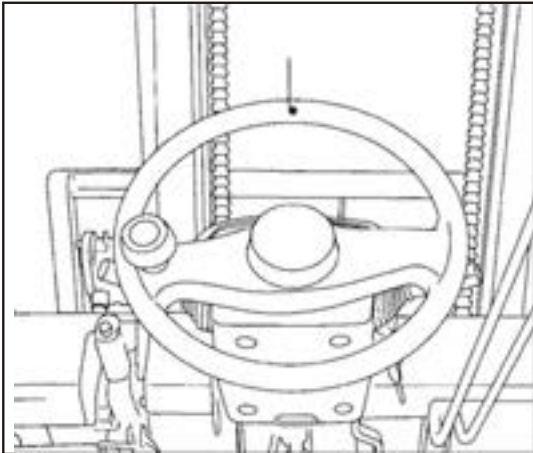

STEERING WHEEL

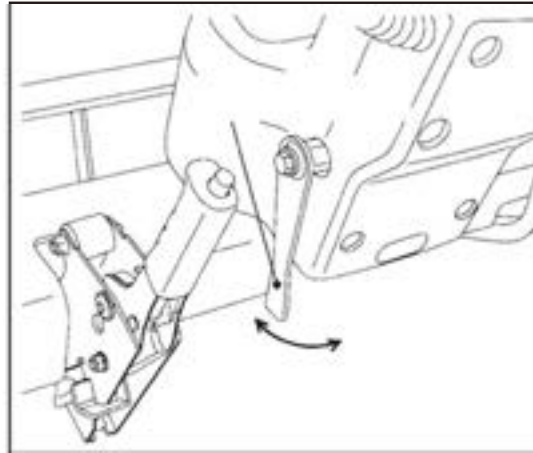

STEERING COLUMN TILT LEVER

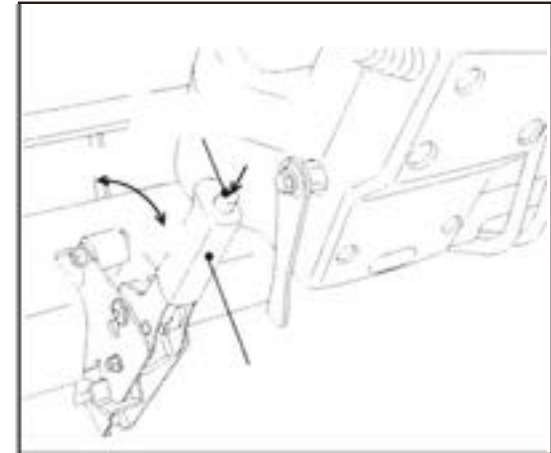

PARKING BRAKE LEVER

⚠ CAUTION

When the engine is not running, power steering is inoperative. If the engine stops during operation, restart the engine as soon as possible.

When traveling the truck, hold the steering wheel knob with your left hand. Do not remove your hand from the knob during traveling. The truck comes with power steering to provide smooth, light steering while the engine is running.

⚠ CAUTION

Adjust the steering column angle properly before starting the day's work or shift. After adjustment, turn the lever in the direction "A" to lock the steering column securely. Do not try to adjust the steering column angle during operation.

Adjust the steering column angle according to the individual operator's physique. Turn the lever in the direction "B" and adjust the steering column angle properly, and then turn the lever in the direction "A" to lock securely.

⚠ CAUTION

Block the wheels when parking on an incline.

Pull back on the lever to apply the brakes to the front two wheels. The lever is locked there. To release the parking brake, press and hold down the lock release button on the tip of the lever while pushing forward on the parking brake lever.

INSTRUMENTS AND CONTROLS

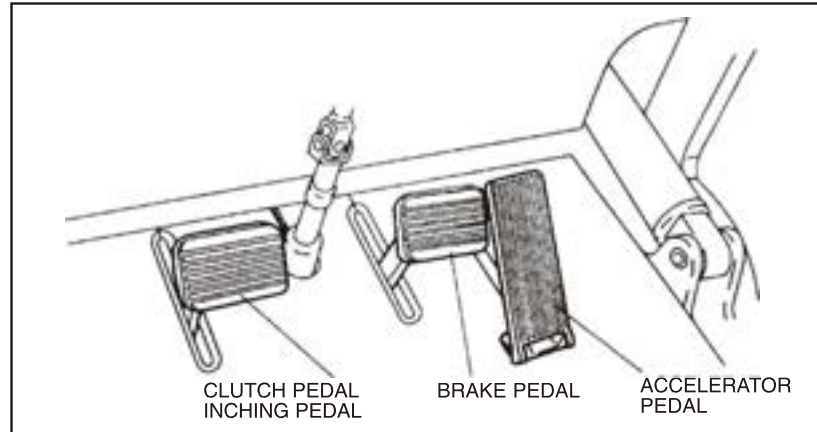

PEDALS

The truck has three foot controls: clutch (or inching pedal), brake pedal and accelerator pedal.

CLUTCH PEDAL (C TYPE)

The clutch pedal turns on and off the power transmission from the engine. The clutch is disengaged by pressing the pedal and engaged by releasing.

NOTE

Do not travel the truck with the clutch engaged slightly, as much as possible.

INCHING PEDAL (T TYPE)

CAUTION

Do not press the inching pedal for slowing down the traveling speed, when starting uphill, or when descending downhill; otherwise the clutch is disengaged to make engine braking unavailable.

Use the inching pedal to move the truck slowly while operating the load handling means at high speed.

When the inching pedal is pressed slightly, the hydraulic clutch pressure drops (clutch engaged slightly). If the pedal is further pressed, the clutch is completely disengaged and the brake is applied to the truck.

For more information, look up "Using the inching pedal" on page 3-4.

BRAKE PEDAL

Press the brake pedal to slow down the truck. Brake lamps come on when the brake pedal is pressed.

ACCELERATOR PEDAL

Press the accelerator pedal to increase engine speed. When the accelerator pedal is released, the engine runs at idle rpm.

TRUCK BODY

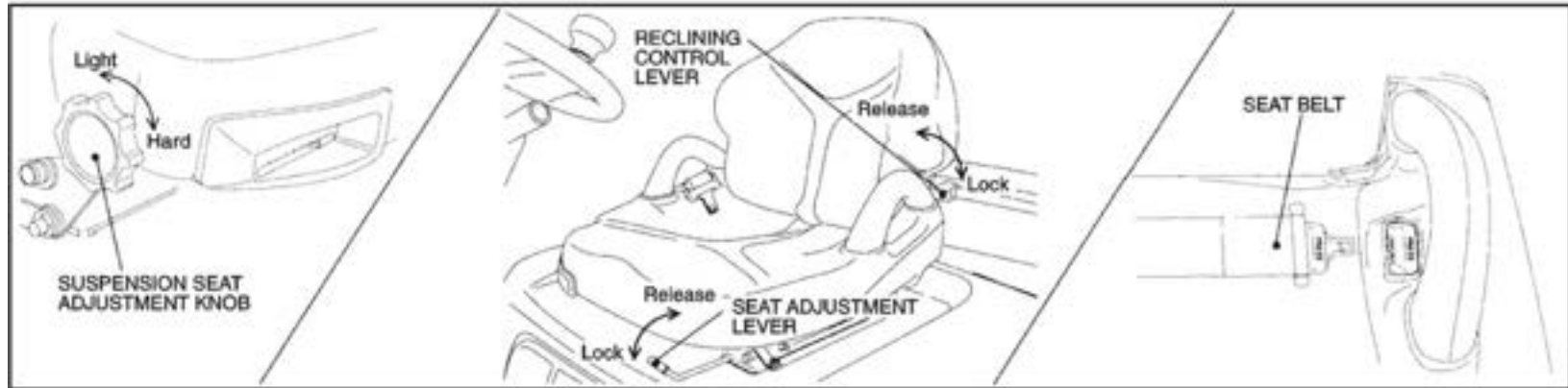

DRIVER'S SEAT SUSPENSION (OPTIONAL)

⚠ CAUTION

Adjust the suspension of the driver's seat using the adjustment knob before starting the day's work or each shift. Do not try to adjust the suspension during operation.

Adjust the driver's seat suspension properly to suit the individual operator's physique and to provide best comfort. Turn the adjustment knob to the value of your weight. The seat absorbs shock and vibration to provide comfort during traveling and operation.

SEAT ADJUSTMENT LEVER RECLINING CONTROL LEVER (OPTIONAL)

⚠ CAUTION

Adjust the seat position before starting your day's work or each shift. Make sure the seat is securely locked.

Adjust the driver's seat to a position to suit the individual operator's physique. To unlock, pull up the lever. After adjustment, try to move the seat back and forth to make sure that the seat is securely locked.

DOCUMENTS POCKET AND MAGAZINE BOX

The driver's seat has a document pocket and magazine box at its back. Use them for storing the Instruction Manual and others. Remember to close the document pocket before operation.

SEAT BELT

⚠ WARNING

Be sure to fasten the seat belt before starting traveling or operation; otherwise, if the truck turns over, the operator might be thrown out and, in the worst case, the operator can be crushed by the truck causing severe injury or even death.

Pull out the connector at the right side and insert it into the receptacle at the left side until it clicks into place.

To unfasten the seat belt, press the red button by the receptacle, and the belt automatically winds up into the seat.

INSTRUMENTS AND CONTROLS



ENGINE HOOD OPENING HANDLE

⚠ CAUTION

Use caution not to pinch your hand when closing the engine hood.

The engine hood can be opened full easy maintenance and service. Push down the front of engine hood when closing it, making sure it is locked.

Drawing out the handle, the engine hood opens slowly.

INSTRUMENTS AND CONTROLS

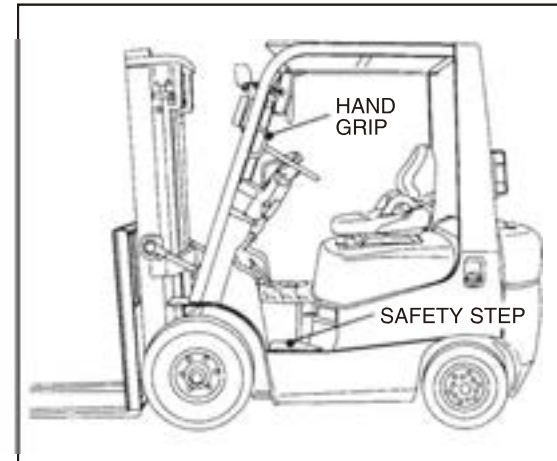
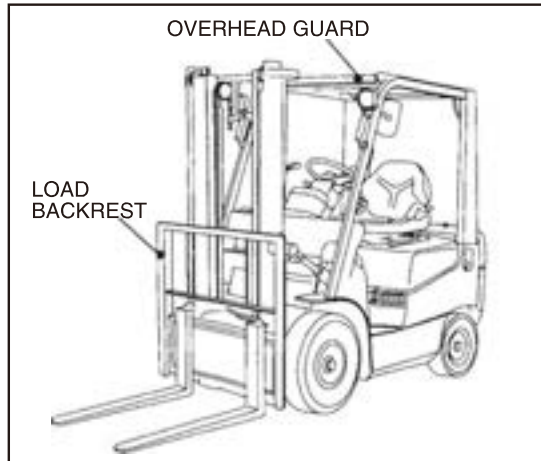

OVERHEAD GUARD

WARNING

The overhead guard is an important safety device which protects the operator from falling objects.

Make sure it is securely installed. Do not use the truck with the overhead guard removed or modified; otherwise it might cause a serious accident.

NOTE

Keep the vinyl rain gutter always clear of dust.

LOAD BACKREST

CAUTION

The load backrest is an important safety device which protects the operator from a falling load if the forks disengage from the carriage. Make sure the load backrest is securely installed. Do not use the truck with the load backrest removed or modified; otherwise it might cause a serious accident.

SAFETY STEP AND HAND GRIP

CAUTION

Use the safety step and hand grip when mounting and dismounting. Do not hold the levers when getting on or off. Do not mount or dismount while the truck is in motion.

The truck is equipped with safety steps at right and left sides of the truck body and a hand grip on the left front pole of the overhead guard. When mounting or dismounting, use the safety step and hand grip.

INSTRUMENTS AND CONTROLS

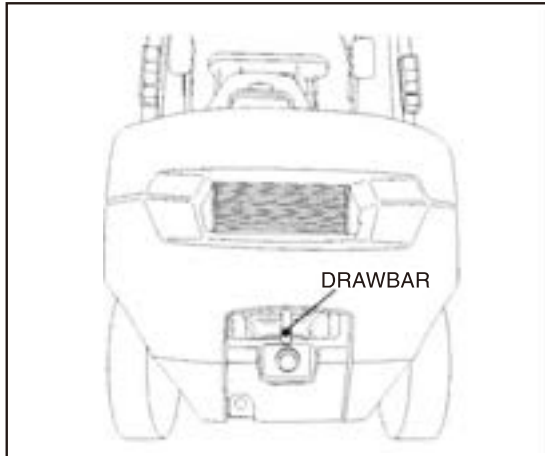

DRAWBAR

⚠ CAUTION

Do not use the drawbar for towing another vehicle or for being towed by another vehicle.

Use the drawbar for the following cases:

- When the truck has bogged down in the mud or a side ditch.
- When loading onto or unloading from a trailer for transportation.

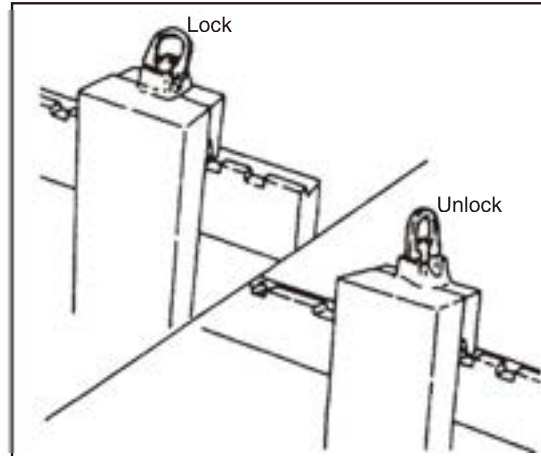

FORK STOPPER

⚠ CAUTION

- The forks should be set symmetrically to the truck centerline, and fork stoppers should always be set.
- When adjusting fork spacing, hold the load backrest and push the forks with your foot. Do not use your hand.

Secure the forks with the fork stoppers. Pull up the fork stoppers a little and turn 90°. Then adjust the fork spacing using your foot according to the size of the load you are going to carry.

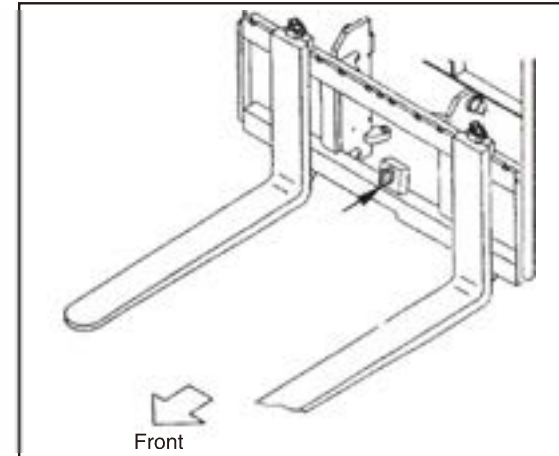

FORK LOCK BOLT

⚠ CAUTION

Do not remove the fork lock bolt other than the following cases; otherwise the forks might disengage from the carriage, causing personal injury.

- When removal of the forks is needed.
- When gathering the right and left forks together to the center for any reason.

When a fork prong is moved to the center, it will come off the carriage. This bolt prevents the fork from being used at the center.

INSTRUMENTS AND CONTROLS

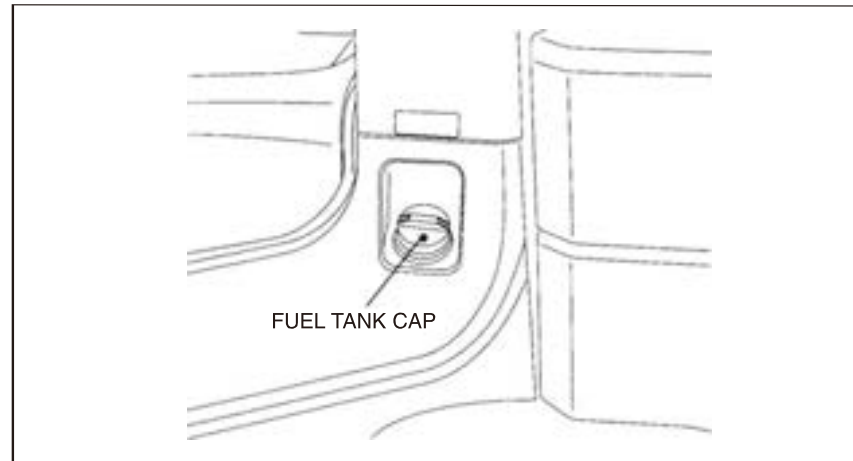

FUEL TANK CAP

⚠ CAUTION

- When adding fuel, stop the truck, shut down the engine, and apply the parking brake securely. Never smoke. Keep fire or naked flame away from the truck. The operator must get off the truck.
- After adding fuel, tighten the cap securely. A loose fuel cap might cause fuel leaks, leading to a serious accident.
- Before starting the engine, make sure the fuel tank cap is securely tightened and any spilt fuel wiped away.

- **Never use naked flame (match or lighter) for checking the fuel level**

The fuel tank cap is located at the left side of the truck.

Turn the cap counterclockwise to open. Inside the cap is breather which allows the entrance of air into the tank.

Make sure the breather is not damaged or clogged; otherwise the fuel system might malfunction.

👉 NOTE

- Use light oil for diesel engine trucks.
- **Diesel fuel**
Use good quality of light oil as diesel fuel. The light oil freezes when the ambient temperature is below -10°C (14°F), causing the fuel piping to become clogged. If the truck is to be used in cold regions, use proper quality of light oil according to the weather condition of the region.
- Do not use kerosene as the fuel; otherwise the engine performance will be deteriorated or the fuel injection pump might be damaged.

INSTRUMENTS AND CONTROLS



LIGHTS AND LAMPS

CAUTION

Check that lights and lamps come on and off properly. If any light bulb is blown out, replace with a new one. If the lens is contaminated or damaged, clean or repair.

Front side

The truck has head lamps (B) and front combination lamps (C) (turn signal and clearance lamps) at its front side.

Rear side

The truck has rear combination lamps (tail lamps (D), brake lamps (E), back-up lamps (F), turn signals (G) and rear reflector) at its rear.

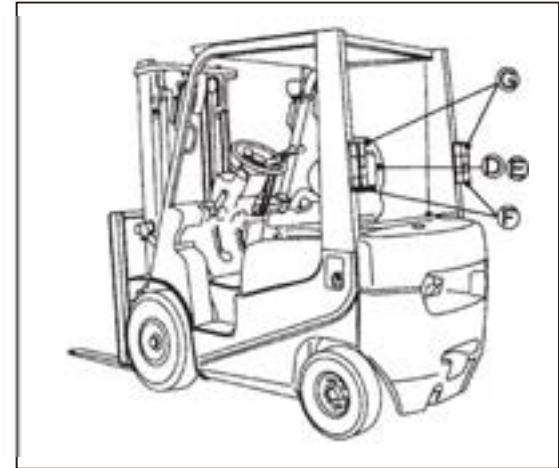

SIDEVIEW MIRRORS

CAUTION

- When traveling in reverse, always look in the direction of travel. Do not rely too much on the sideview mirrors.
- Keep the mirror surfaces always clean.
- Adjust the sideview mirrors to gain full rear vision.

The sideview mirrors are provided on the front poles of the overhead guard, one for each.

INSTRUMENTS AND CONTROLS

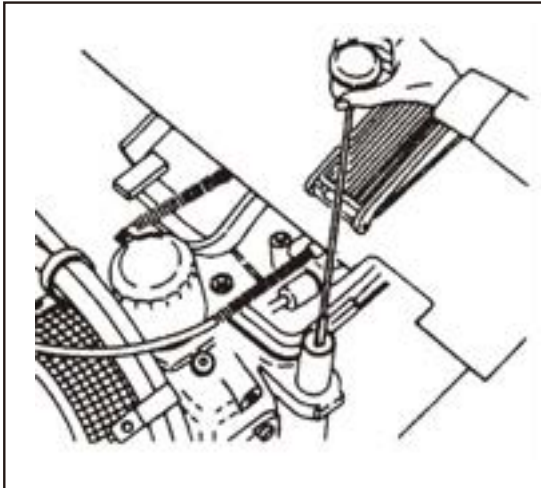

TORQUE CONVERTER OIL FILLER (T TYPE)

The torque converter oil filler is located under the floorboard. The filler has a cap with an oil dipstick.

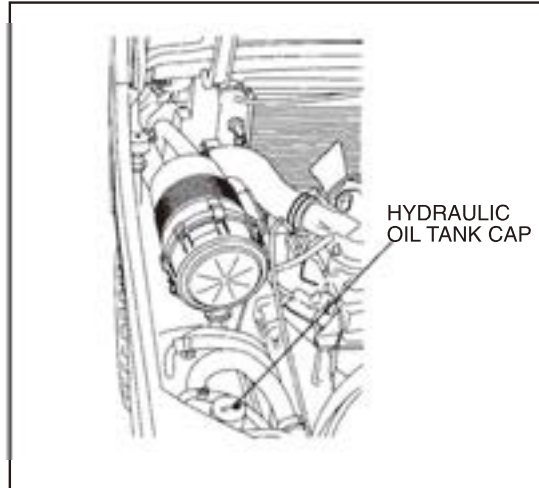

HYDRAULIC OIL TANK CAP

The hydraulic oil tank cap is located at the right area inside the engine hood. The cap is provided with an oil dipstick.

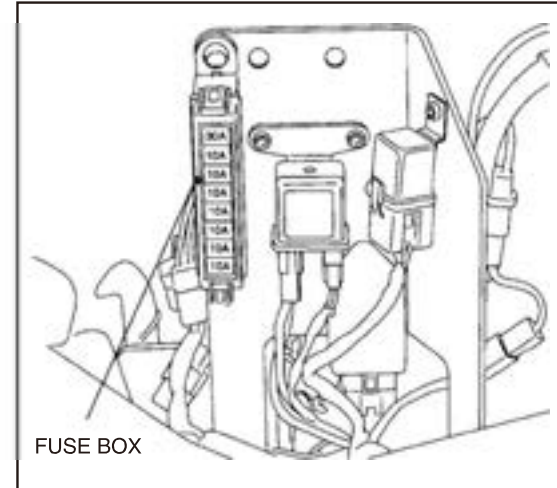

HYDRAULIC OIL TANK CAP

The fuse box is located at the left area inside the engine hood.

INSTRUMENTS AND CONTROLS

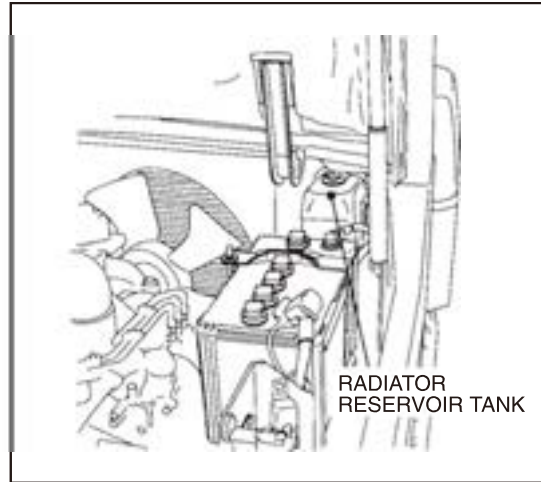
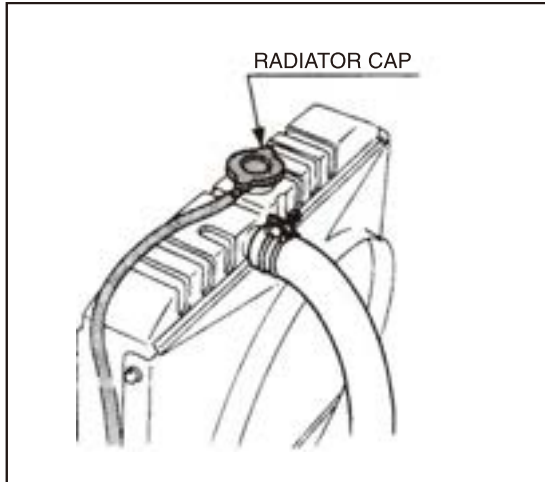

RADIATOR CAP

CAUTION

Do not remove the radiator cap abruptly while the engine is hot. Make sure the engine has cooled down completely and turn the cap counterclockwise a little to relieve the pressure in the radiator, and then remove the cap.

The radiator cap is located inside the cover at the rear part of the engine hood. To remove the cap, turn it 90.

RADIATOR RESERVOIR TANK

The radiator reservoir tank is located behind the battery unit inside the engine hood. You can check the cooling water level using this tank.

INSTRUMENTS AND CONTROLS

OPTIONAL EQUIPMENT

Here are some pieces of optional equipment which are deeply related to safe operation of the truck. For more information about optional equipment, consult your local dealer. Also see page 5-13.

REAR WORK LIGHT (RWL)

CAUTION

It is advisable to use an optional rear work light when you are working in a place where sufficient light is not available.

The rear work light illuminates the road or floor behind the truck at night to allow the operator to recognize obstacles, if any, on the road or floor easily.

BEACON LIGHT

Use an optional beacon light in the case when the truck is required to work near fellow workers or bystanders or when the work place is noisy.

SOUND VOLUME-ADJUSTABLE BACK-UP BUZZER

You can switch over the sound volumes in two stages, according to the noise level at the work place.

SPEEDMETER (SM)

The speedometer indicates the traveling speed (km/h) and the distance traveled by the truck.

When the light switch is turned on, the dial is illuminated by a built-in lamp.

SPEED ALARM SYSTEM (SAS)

The SAS gives an alarm by sounding the buzzer and flashing the beacon light when the traveling speed exceeds the preset speed. The speed can be preset for 5 km/h, 10km/h or 15 km/h.

HIGH LOAD BACKREST (HBR)

Use the high load backrest for handling high loads.

OVERHEAD GUARD WITH WIRE NETTING

The overhead guard with wire netting protects the operator from falling objects, especially when handling small parts at a high place.

PNEUMATIC TYPE CUSHION TIRE (UNIQUE TIRE, TR01)

Use tires of this type when you are going to work in an area where there are debris or anything that might blow the tires on the road or floor surface.

FIRE EXTINGUISHER (FE)





Use the fire extinguisher for putting out a fire. An optional fire extinguisher will be attached to one of the rear supports of the overhead guard.

NOTE

A series of horizontal dashed lines for writing notes.

The following symbols, found throughout this manual, alert you to potentially hazardous conditions to the owner and the operator. Become completely familiar with the truck before proceeding with operating, checking and servicing.

This manual and decals affixed to the truck use the following safety alert indications.

SIGNAL WORD	CLASSIFICATION
 DANGER	Failure to follow the instructions in the message will likely cause a serious accident or death.
 WARNING	Failure to follow the instructions in the message might cause a serious accident or death.
 CAUTION	Failure to follow the instructions in the message may cause personal injury or damage to the truck or other property.
 NOTE	The information will help to prolong the service life of the truck. The message is not directly related to accident prevention.

3. OPERATION

CONTENTS

PROPER OPERATION.....	3- 2
DURING BREAK-IN.....	3- 2
RELATIONSHIP BETWEEN LOAD AND STABILITY OF TRUCK.....	3- 2
BASIC LOAD CENTER AND RATED LOAD.....	3- 3
THE STABILITY OF LIFT TRUCK.....	3- 4
USING INCHING PEDAL (T TYPE).....	3- 4
TRAVELING AND STARTING ON A SLOPE.....	3- 4
TRANSPORTING LIFT TRUCK.....	3- 5
OPERATING LIFT TRUCK.....	3- 5
MEASURES AGAINST COLD OR HOT WEATHER.....	3-11
IN COLD WEATHER.....	3-11
IN HOT WEATHER.....	3-13
LOAD HANDLING.....	3-14
PICK-UP.....	3-14
STACKING.....	3-14
UNSTACKING.....	3-15
STORING.....	3-16
BEFORE STORING; DAILY STORAGE.....	3-16
LONG-TERM STORAGE; OPERATING AFTER LONG-TERM STORAGE.....	3-17

PROPER OPERATION

To operate the lift truck safely and get the most out of it, correct procedures are described on the following pages:

DURING BREAK-IN

We recommend to operate the truck under light load conditions for the first stage of operation to get the most from it. Especially, the requirements given below should be observed while the truck is in a stage of 200 hours of operation.

- ⚠ Always warm up your truck before putting it into work regardless of the seasons.
- ⚠ Perform specified preventive maintenance services carefully and completely.
- ⚠ Never "race" or play games with the truck. Avoid sudden stops, starts or turns.
- ⚠ Oil changes and lubrication are recommended to do earlier than specified.
- ⚠ Do not run the engine needlessly at high rpm without load.

RELATIONSHIP BETWEEN LOAD AND STABILITY OF TRUCK

The lift truck keeps a balance of weight between the truck and the load on the forks with the center of the front wheels as a fulcrum when the rated capacity load is placed in position.

Due care should be paid to the weight and the load's center of gravity to maintain stability.



If the rated capacity is exceeded, there is a danger of the rear wheels being raised and in the worst case, the truck will turn over, resulting in a fatal accident. The load placed near the fork tips practically has the same effect that the weight of the load is increased. In this case, the load weight must be reduced accordingly.

BASIC LOAD CENTER AND RATED LOAD

⚠ CAUTION

- When traveling with loads, keep the forks 15 to 20 cm (6 to 18 in.) above the ground surface and keep the mast tilted back fully.
- The allowable load of a truck equipped with an attachment is reduced in comparison with that of the standard truck.

If the truck is equipped with a load-handling means such as a hinged fork, load grab, or rotating clamp, its allowable load will be reduced as compared with that of the standard truck (a truck without any attachment) for the following reasons:

Never exceed the allowable load indicated on the load chart attached onto the truck or attachment.

Reasons for a reduction in the allowable load:

- The weight of an attachment is added.
- The attachment shifts the basic load center position forward, and thus the allowable load is reduced.

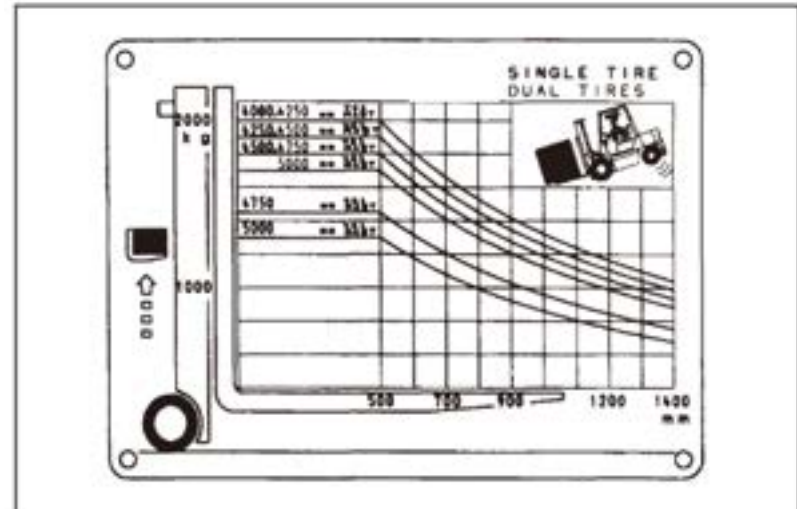

The basic load center is the distance from the front face of the forks to the load's center of gravity. The chart given above shows the relationship between the basic load center and the weight of loads to be allowable for the 2-ton truck. This chart is called a load chart and is attached to the truck.

PROPER OPERATION

THE STABILITY OF LIFT TRUCK

The stability of lift trucks is stipulated in inter-national industrial standards, and lift trucks are manufactured complying with these standards. However, note that the stability of lift trucks is not assured at all times, but only when the following conditions are properly observed.

- **The ground or floor surface is level and hard.**
- **The truck travels under standard loaded or unloaded condition.**
- **The truck is operated carefully and the forks are properly manipulated; that is, the forks are not tilted forward more than necessary, when stacking or unstacking.**
Load handling is carried out carefully and slowly.

In addition, keep the truck in good working condition for safe operation and traveling.

Standard unloaded condition

This means that the forks are raised 30 cm (12 in.) above the ground or floor surface and tilted back fully without loads.

Standard loaded condition

This means that the forks are raised 30 cm (12 in.) above the ground or floor surface with a load placed at the basic load center position of the forks.

USING INCHING PEDAL (T TYPE)

The inching pedal works in the same manner as the clutch pedal of the C type truck.

Use the inching pedal to move the truck inch by inch while operating the load handling means at high speed.

- 1) Press the inching pedal to the floor.
- 2) Place the direction shift lever into the forward (or reverse) position.
- 3) Step on the accelerator pedal gradually while releasing the inching pedal little by little, to move the truck inch by inch.

TRAVELING AND STARTING ON A SLOPE

■ When traveling on a slope with a load on the forks, have the load pointed up-hill.

When traveling on a slope without load, have the rear end of the truck pointed up-hill to prevent the drive wheels from skidding.

■ When descending or on a slope, use the brake pedal, but not the inching pedal. If the inching pedal is pressed on a downward slope, engine braking will not be available to make it difficult to brake the truck. If the inching pedal is used when starting the truck on an uphill slope, the truck might slip down.

TRANSPORTING LIFT TRUCK

CAUTION

Transporting the lift truck on a trailer truck

- Securely lock the lift truck in place to prevent it from moving on the trailer truck by fastening with wire ropes and blocking the wheels.
- When loading or unloading the lift truck onto or from a trailer truck or when traveling over public roads, pay attention to the overall length, overall height, and weight and observe the local traffic regulations.

CAUTIONS TO BE TAKEN WHEN LOADING AND UNLOADING LIFT TRUCK

CAUTION

- Never try to move the steering wheel when halfway up a ramp; otherwise the truck might fall down, leading to a serious accident.
- Use ramps of sufficient length, width, and strength.
- Before loading or unloading the lift truck, make sure to apply the parking brake to the trailer truck and block its wheels.
- Ramps must be securely locked to the trailer truck. Their surface must be clean and dry.
- Loading and unloading must be carried out on a level surface. The right and left ramps must be the same height.
- When loading the lift truck onto a trailer truck, back it up the ramps slowly with care.

OPERATING LIFT TRUCK MOUNTING AND DISMOUNTING

CAUTION

Do not hold the steering wheel when mounting or dismounting. Do not jump on or off the truck. You could slip or fall and get injured.

- 1) Make sure there is no approaching vehicle or passerby. Make sure the truck is at a complete stop.
- 2) Get on or off the truck from the left side of the truck, using the safety step and hand grip properly.
- 3) Fasten your seat belt securely. The seat belt helps protect you if there is an accident.

STARTING ENGINE AND AFTER ENGINE HAS STARTED

CAUTION

- Do not try to start the engine unless you are seated properly in the driver's seat.
- Make sure there is no one around the truck before starting the engine.
- When starting the engine indoors, open the windows or doors and run the fan to prevent exhaust gas poisoning.

Make sure the shift lever is in neutral "N" and the parking and the parking brake is applied securely.

- 1) Seat yourself in the driver's seat and insert the starter key into the starter switch.

PROPER OPERATION

- 2) Press the clutch pedal to the floor (C type) or brake pedal (T type) and turn the starter switch to "START"(do not keep the starter switch at "START" more than 10 seconds) to crank the engine.
- 3) Once the engine has started, remove your hand from the key and release the accelerator pedal. The starter key will automatically return to the "ON" position.
- 4) After the engine has started, do not increase the engine speed rapidly. Warm up the engine and make sure the CHARGE warning light and ENGINE OIL PRESS, warning light go out. In addition, make sure the meters are operating normally. After the engine speed has stabilized, warm up the engine
- 5) further at idling rpm.

WARMING UP ENGINE

Make sure to warm up the engine for about 5 minutes regardless of whether the ambient temperature is cold or not.

If the truck is operated before warming up the engine sufficiently, the inside of the engine is not properly lubricated and the combustion is incomplete, thus resulting in a damaged engine.

STARTING COLD ENGINE

In a cold climate, the battery performance drops and the viscosity of the lubricating oil increases to make it difficult to crank the engine.

Start a cold engine using the following manner:

Diesel engine trucks

The preheating operation is automatically controlled according to the cooling water temperature.

turn the starter key clockwise to the "ON" position.

When the cooling water temperature is below 60°C (140°F), the glow indicator comes on and preheating of the engine will be completed in about 3.5 seconds and the glow indicator goes out.

When the cooling water temperature is more than 60°C (140°F), the glow indicator comes on for 0.3 seconds and then goes out. When the glow indicator goes out, press the accelerator pedal and turn the starter key to the "START" position to start the engine.

Do not keep the starter motor engaged for more than 10 seconds at a time.

PROPER OPERATION

WHEN ENGINE WON'T START

CAUTION

Never try to start the engine by pushing or towing the truck.

- Do not keep the starter motor engaged for more than 10 seconds at a time. If the engine does not start 10 seconds after engaging the starter motor, stop the operation of the starter motor. Wait for a while and start all over again.
- If the engine is hard to start despite several tries, check the fuel level in the fuel tank, the fuel system for mixing of air, or the electrical wiring for a broken wire.
- The engine might not start if the starter motor does not reach a specified rpm. If this is the case, start the engine using an auxiliary battery and booster cable.

NOTE

For "Starting with Auxiliary Battery" see page 4-26.

BEFORE STARTING LIFT TRUCK

CAUTION

Make sure there is no one around the truck and let other workmen and bystanders know you are starting up by honking

- 1) Pull back on the lift lever to raise the forks 15 to 20 cm(5.9 to 7.8 in) from the ground or floor surface.

- 2) Pull back on the tilt lever to tilt back the mast fully.
- 3) Make sure there is no one around the truck and let other workmen and bystanders know you are starting up by honking.

STARTING LIFT TRUCK

CAUTION

Slow down when:

- Making turns
- Running at narrow aisles
- Running on rough surfaces
- Approaching to loads or obstacles.

C TYPE

- 1) Press the clutch pedal to the floor.
- 2) Place the direction shift lever in the forward (reverse) position.
- 3) Place the speed range shift lever in the low position.
- 4) Release the parking brake lever.
- 5) Press the accelerator pedal while releasing the clutch pedal slowly to start the truck.

NOTE

Do not keep your foot on the clutch pedal after the truck has started; otherwise the clutch disk will wear out prematurely.

PROPER OPERATION

T TYPE

CAUTION

Press the brake pedal to the floor before placing the shift lever into the forward (or reverse) position; otherwise the truck starts moving slowly or creeps when the shift lever is placed into forward or reverse.

NOTE

Do not keep your foot on the inching pedal during traveling after the truck has started.

- 1) Press the brake pedal.
- 2) Place the shift lever in the forward (or reverse) position.
- 3) Release the parking brake lever.
- 4) Release the brake pedal and press the accelerator pedal to start the truck.

GEARSHIFTING

CAUTION

When traveling in reverse, look in the direction of travel and be alert for pedestrians, other trucks or obstacles in your path of travel. Do not rely too much on the side view mirrors.

C TYPE

- When reversing the direction of travel, from forward to reverse or vice versa, be sure to bring the truck to a complete stop.
- When changing the speed range from Low to High or vice

versa, start the truck and accelerate the speed. Then, release the accelerator pedal while pressing the clutch pedal and change the speed range. Press the accelerator pedal while releasing the clutch pedal quickly.

T TYPE

When reversing the direction of travel, from forward to reverse or vice versa, be sure to bring the truck to a complete stop.

SLOWING DOWN

C TYPE

Release the accelerator pedal and press the clutch pedal. Place the speed range shift lever into Low and press the accelerator pedal. Press the brake pedal as necessary.

T TYPE

Ease up on the accelerator pedal. If necessary, press the brake pedal.

TURNING

CAUTION

Note that the rear end (counterweight) of the truck swings when you turn the truck.

Unlike general passenger cars, the steer wheels are located at the rear of the truck. This causes the rear end of the truck to swing out when a turn is made. Slow down the truck and move toward a side to which you are turning. The steering wheel should be turned a bit earlier than as with the front-wheel steering car.

- Grab the steering wheel knob with your left hand.
- Your right hand is used to operate the load handling levers.

PARKING

Slow down the truck and press the brake pedal to bring the truck to a stop. Press the clutch pedal (C type) and place the shift lever into the neutral "N" position.

NOTE

Do not stop the truck on an up-hill slope by controlling the accelerator pedal; otherwise the clutch disk will wear out or the torque converter oil temperature will rise abnormally.

CAUTION

Safeparking

- Park the truck on a level ground, preferably in a wide area.
If parking the truck without load on a slope is unavoidable, position the load handling means down-hill and block the wheels to prevent accidental roll.
- Park the truck in a designated area or out-of-traffic area. If necessary, put signposts or signal lights around the truck.
- Park the truck on a hard ground. Avoid soft ground, deep mud or slippery surfaces.
- If you cannot lower the forks on the ground due to a broken load handling system, put a caution cloth to the fork end and park in an out-of-traffic area.
- Pay attention to the ground condition because it might be slippery.
- Dismount from the truck after making sure it has come to a complete stop. Do not dismount from the truck in motion.
- Never jump off the truck.
- Dismount from the truck, facing the truck and using the safety step and hand grip.

Park the truck in an out-of-traffic area and follow the procedure given below:

- 1) Pull the parking brake level to the full to apply the parking brake.
- 2) Lower the forks on the ground.
- 3) Turn the key switch "QFF" to shut down the engine.
- 4) Dismount from the truck carefully.

PROPER OPERATION

GROUND CONDITION

CAUTION

- Use due caution when traveling on a rough surface.
- When crossing a railroad, be sure to once stop, make sure to be safe and cross the railroad track at an angle wherever possible.
- Go around obstacles such as rocks and stumps, or pot holes. If unavoidable, reduce the speed and go over slowly and carefully. Use caution not to damage the bottom of the truck. Cross a small bump diagonally if the aisle width is enough to do so.

Lift truck performance depends upon the ground condition or floor condition and travel speed should be adjusted properly.

TRAVELING ON SNOWY OR FROZEN ROAD

CAUTION

Note that fitting of optional tire chains will increase traction, but can hardly prevent the truck from sideslipping.

When traveling on a snowy or frozen road, use tire chains. Avoid sudden acceleration, stops or turns; otherwise the truck might skid to cause a serious accident.

Control the traveling speed carefully using the accelerator pedal.

NOTE

Some trucks require the replacement of some parts when using tire chains.

For more information, consult your local dealer.

MEASURES AGAINST COLD OR HOT WEATHER

IN COLD WEATHER

When using the truck in a cold weather, special care should be taken more than when using it in a hot weather.

Caution to be taken when adding fuel

CAUTION

When adding fuel, make sure to shut down the engine.
Never smoke.

Add fuel up to the upper limit of the tank. This will help prevent the freezing of water content contained in the air inside the tank or the fuel system from corroding, which makes it difficult for the engine to start.

NOTE

Make sure the fuel cap is securely tightened.
(A loose cap will allow rain water or snow to enter the fuel tank.)

Caution to be taken for the cooling system

CAUTION

Handling LLC

- The LLC is flammable. Do not use open flame when adding, changing or storing it.
- The LLC is poisonous. (Lethal dose: 100 cc). Do not swallow it. If anyone swallowed it accidentally, induce vomiting immediately and get medical attention.
- When storing, put a sign "Dangerous substance" and keep it out of reach of children.

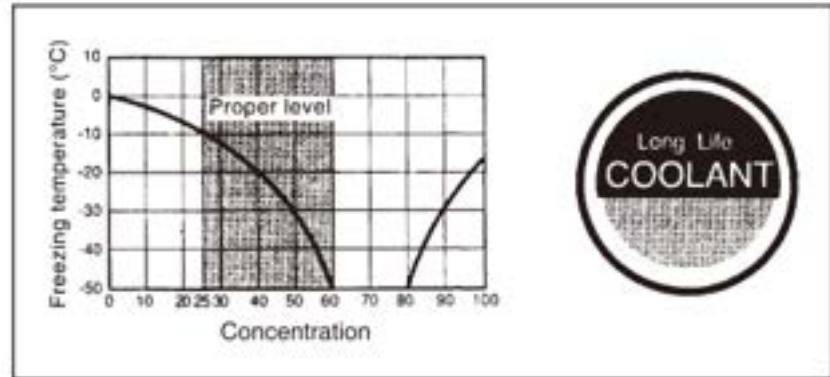

Frozen cooling water might damage the engine or radiator.

When the ambient temperature is anticipated to be below 0°C, add anti-freeze into the cooling water. If you do not use antifreeze, make sure to remove all the cooling water after the day's work. When the truck has a label given at the right, it uses cooling water containing 50% LLC (Long Life Coolant). If this is the case, there is no need to change the cooling water for 2 years.

When addition of cooling water is needed, use cooling water containing one part of water and one part of LLC.

MEASURES AGAINST COLD OR HOT WEATHER

Battery care

CAUTION

Never pour hot water over the battery case even if you find it difficult to start the engine. The battery case might break, causing a serious accident.

The battery hardly freezes and works efficiently when it is completely charged and has a greater specific gravity of the electrolyte.

If the electrolyte freezes, the battery case will be broken. Keep the battery in fully charged condition at all times.

The battery electrolyte usually freezes at about -35°C when the battery is in a fully charged condition.

To prevent freezing

- Keep the battery's state of charge to more than 70%.
- Keep the specific gravity of electrolyte at 1.280 or less.
- When the truck is not in use, remove the battery from the truck and store in a warm place.

NOTE

When adding purified water to the battery, make sure to add it immediately before charging or starting the truck.

DANGER

Cautions to be taken when handling battery

Cases produced by the battery can be explosive. Do not smoke. Do not use open flame for inspection.

- No fire. Do not smoke. Keep sparks or open flame away from the battery.
- Keep proper electrolyte level. If the level is too low (below LOWER LIMIT), the battery will build up heat, leading to an explosion.
- Have a good ventilation. Do not use or store batteries in a closed place or an area where ventilation is poor.
- Avoid electroshock accident. Wear rubber gloves when servicing and inspecting the battery.
- Sulfuric acid. The electrolyte is sulfuric acid and thus it might cause burns or blindness if it comes in contact with the skin, eye, or clothing.
- If electrolyte comes in contact with your skin or clothing, wash it away using a copious amount of water immediately. If electrolyte gets into your eyes, wash your eyes with a copious amount of water immediately and get medical attention.

MEASURES AGAINST COLD OR HOT WEATHER

IN HOT WEATHER

Cooling system

 **CAUTION**

Make sure the engine is cold before opening or closing the radiator cap. Hot cooling water might spout out to cause serious burns.

To get a good cooling effect, use caution not to allow leakage of cooling water and the forming of scale or corrosion in the cooling system.

- In hot weather, the cooling system is apt to cause scale or corrosion. Use caution to get the circulation of clean water at all times. The LLC can be used for all seasons, because it has anti-rust and anti-corrosion effect in addition to anti-freezing effect.
- A clogged radiator fin will cause an overheated engine. Keep the radiator fins always clean. In addition, check for water leaks.
- Check for a loose fan belt. If the fan belt is loose, adjust it for the specified tension.

Measures to be taken when the engine has overheated

 **CAUTION**

If the engine has overheated, do not open the radiator cap. In addition, do not touch the radiator reservoir tank. Hot steam might spout out, causing burns.

When the engine has overheated:

- 1) Let the engine run at idle rpm for a while and open the engine hood fully to get a good ventilation.
- 2) After making sure the temperature of the cooling water cools down sufficiently, shut down the engine.
- 3) Open the reservoir tank and add cooling water.
- 4) Check for water leaks of the cooling system, clogged radiator fin, and loose fan belt.

LOAD HANDLING

PICK-UP

CAUTION

The fork spacing should be usually adjusted for more than 1/2 and less than 3/4 of the pallet opening.

- 1) The fork spacing should be as wide as possible to maintain proper balance of the load.
- 2) Place the truck right in front of the load to be handled.
- 3) The pallet should be evenly positioned across both forks.
- 4) Insert the forks into the pallet as far as possible.
- 5) To raise the load from the ground:
 - ① Once lift the forks 5 to 10 cm off the ground or floor surface, and make sure the load is stable.
 - ② After making sure the load is stable and evenly positioned on the forks, tilt back the mast fully and lift the forks up to 15 to 20 cm off the ground or floor surface. Start running.
- 6) When handling a bulky load which restricts your vision, drive the truck in reverse.

STACKING

CAUTION

- Never tilt the mast forward with the load upraised except when the forks are over the rack or a stack.
- Do not leave the truck with the load upraised.

- 1) When approaching the deposit area, slow down your truck.
- 2) Once stop the truck right in front of the area where your load is to be deposited.
- 3) Check the condition of the deposit position.
- 4) Tilt the mast forward until the forks become horizontal.
- 5) Raise the forks until they are a little higher than the deposit position.
- 6) Move forward slowly to place the load directly over the desired area and stop the truck.
- 7) Make sure the load is just over the desired area. Slowly lower the load into position. Make sure the load is securely stacked.
- 8) Disengage the forks from the pallet or load using necessary lift-tilt operation, and then back away.
- 9) After making sure the fork tips leave the pallet or load, lower the forks to the basic traveling position (15 to 20 cm 5.9 to 7.8 in) off the ground or floor surface).
- 10) Tilt back the mast.

UNSTACKING

- 1) When approaching the area where the load is to be retrieved, slow down the truck.
- 2) Once stop the truck right in front of the load so that the distance between the fork tips and the load is about 30 cm.
- 3) Check the condition of the stack.
- 4) Tilt the mast forward until the forks become horizontal and lift up to the position of the pallet or skid.
- 5) Make sure the forks are positioned properly for the pallet.
Move forward slowly to insert the forks into the pallet as far as possible. Stop the truck.
 - * If the forks are hard to be fully inserted, use the following procedure:
 - ① Move forward to insert 3/4 of the forks. Raise the forks 5 to 10 cm(1.9 to 3.9 in), back away 10 to 20 cm(3.9 to 7.8 in) with the pallet or skid on the forks. Lower the pallet or skid on
 - ② the stack.
Move forward again to insert the forks into the pallet fully.
- 6) Raise the forks 5 to 10 cm off the stack.
- 7) Check all around the truck to ensure that the path of travel is unobstructed and back away slowly.
- 8) Slowly lower the load to a height of 15 to 20 cm above the ground or floor surface. Tilt back the mast fully and move to the desired area.

STORING

BEFORE STORING

CAUTION

If any time your lift truck is found to be in need of repair, defective or in any way unsafe, the condition should be reported to the supervisor, and the truck should be taken out of service until it has been restored to safe operating condition.

Before storing the lift truck, clean it thoroughly and perform inspection using the following procedure:

- Wipe away grease, oil, etc., adhering to the body of the truck with shop rag. Use water, if needed.
- While washing the truck, check the general condition of the truck. Especially check the truck body for dents or cracks, the tires for wear or nails or stones in the tread.
- Check the fuel level and add if necessary.
- Check for leakage of hydraulic oil, engine oil, fuel or cooling water.
- Apply grease, where needed.
- Check for looseness of the hub nuts and cylinder piston rod joints.
- Check the mast rollers to see that they rotate smoothly.
- Lift the forks up to the top position and lower to the lower limit. Repeat this procedure to prime oil into the lift cylinders.
- Drain off the cooling water completely from the cooling system in winter or cold weather if anti-freeze or LLC is not used.

DAILY STORAGE

- Park the truck at a specified place and block the wheels.
- Place the shift lever(s) in neutral HNH and push in the brake button fully.
- Shut down the engine and operate the load handling levers several times slowly to remove the residual pressure from the cylinders and hoses .
- Remove the starter key and keep it in a safe place.

LONG-TERM STORAGE

Perform the following checks in addition to "BEFORE STORING" and "DAILY STORAGE" services.

- Taking the rainy season into consideration, park the truck at a higher and hard ground.
- Remove the battery from the truck.
- Even though the truck is parked indoors, if the place is hot or humid, the battery should be kept in a dry, cool place, and charged once a month.
- Apply anti-rust to the exposed parts such as cylinder rods and shafts that tend to rust.
- Cover components which may be caught with humidity, such as the air breather and air cleaner.
- Put the truck in the operating state once a week and start the engine. Warm it up sufficiently before moving the truck a little back and forth.
- Avoid parking on a soft ground such as an asphalt ground in summer.

OPERATING AFTER LONG-TERM STORAGE





- Remove covers used to seal off moisture.
- Remove antirust from the exposed parts.
- Drain the crankcase, transmission (C type), differential, and torque converter (T type), clean their inside and add new oil.
- Drain foreign matter and water from the hydraulic oil tank and fuel tank.
- Remove the engine cylinder head cover and lubricate the valves and rocker shafts. Check the valves for proper operation.
- Add cooling water to the specified level.
- Charge the battery and mount it on the truck. Connect the cables.
- Perform pre-operational checks carefully.
- Warm up the engine.

NOTE

A series of horizontal dashed lines for writing notes.

The following symbols, found throughout this manual, alert you to potentially hazardous conditions to the owner and the operator. Become completely familiar with the truck before proceeding with operating, checking and servicing.

This manual and decals affixed to the truck use the following safety alert indications.

SIGNAL WORD	CLASSIFICATION
 DANGER	Failure to follow the instructions in the message will likely cause a serious accident or death.
 WARNING	Failure to follow the instructions in the message might cause a serious accident or death.
 CAUTION	Failure to follow the instructions in the message may cause personal injury or damage to the truck or other property.
 NOTE	The information will help to prolong the service life of the truck. The message is not directly related to accident prevention.

4. MAINTENANCE

CONTENTS

PREOPERATIONAL CHECKS	4- 2
GENERAL RULES ON INSPECTION	4- 2
ITEMS TO BE CHECKED	4- 4
PREVENTIVE MAINTENANCE	4-17
ENGINE ROOM	4-17
ENGINE SPECIFICATIONS.....	4-20
REPLACING TIRES AND REPAIRING FLAT TIRE...	4-23
REPLACING LAMP BULBS	4-24
WHEN YOU CANNOT START THE ENGINE BECAUSE THE BATTERY HAS BEEN EXHAUSTED	4-25
ADJUSTING OPERATING FORCE OF PARKING BRAKE	4-26
PERIODIC INSPECTION	4-27
PERIODICAL REPLACEMENT OF SECURITY PARTS	4-28
MONTHLY (200 HOURS) CHECKS	4-29
3 MONTHS (600 HOURS) CHECKS	4-35
6 MONTHS (1200 HOURS) CHECKS	4-38
ANNUAL (2400 HOURS) CHECKS	4-40
MAINTENANCE INTERVALS	4-41
PREVENTIVE MAINTENANCE SCHEDULE	4-44

PREOPERATIONAL CHECKS

Before starting the lift truck, be sure to inspect the following items for safety sake and increased productivity.

CAUTION

- If any fault is found by preoperational inspection, attach a sign in the control area stating **DO NOT OPERATE**, remove the starter key and report the condition to the supervisor. Operation of the truck should be halted until the truck is completely repaired.
- Check for oil leaks. Remember that oil leaks might cause a fire.
- Waste fluid caused from lubricant change services must not be thrown away thoughtlessly, because they will be a cause of air, water, earth pollution.
The service personnel or employer is required to dispose of it properly.

GENERAL RULES ON INSPECTION

- Use genuine parts only.
- Use genuine or recommended lubricants only.
- Clean the oil fillers and grease fittings using a brush or shop rag before adding oil or fuel or greasing.
- Oil level checks and addition of oil should be made with the truck parked on a level surface.
- Preventive maintenance services should be done in an orderly manner and due care taken to prevent personal injury.
- If unavoidable to work under raised forks or attachment, use a stable support to prevent the forks or attachment from falling down unexpectedly.
- Any time the operator finds that the truck or the controls are not functioning properly, operation of the truck should be halted and the condition reported to the supervisor. Never operate a faulty truck.

PREOPERATIONAL CHECKS

■ General condition

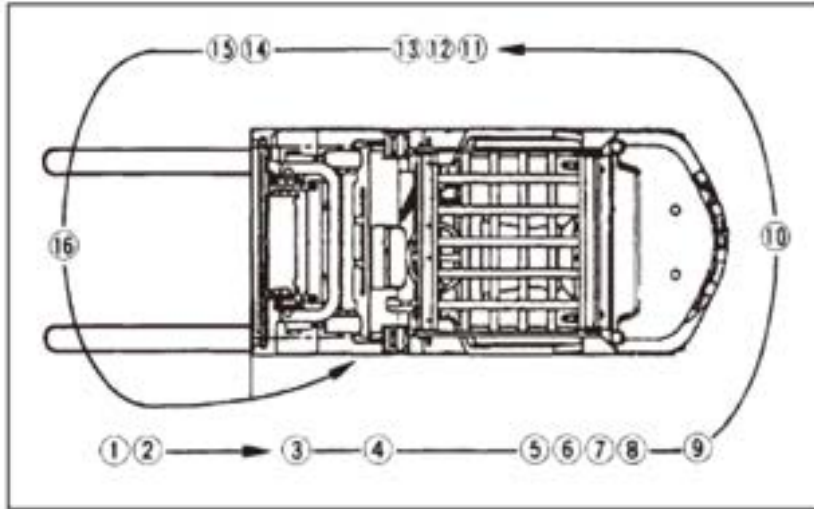

Check the general condition of the truck, in particular, the truck body for dents or cracks and tires for wear or nails caught in the tread.

■ State of the truck

Check the inclination of the truck. If the truck is tilted to either side, it suggests that the tires or wheels are defective. Contact your local dealer.

■ Oil or water leaks

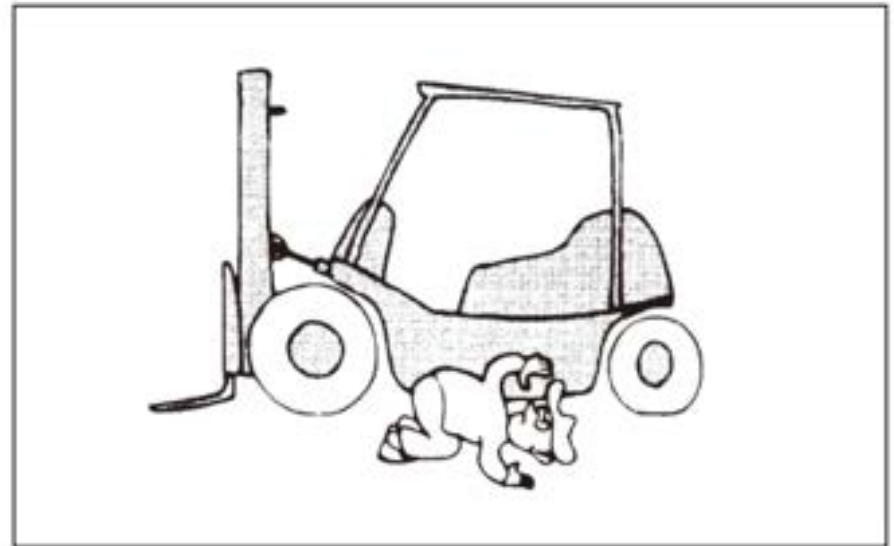

Check for oil or water leaks under the truck. If there is a pool of oil or water on the ground or floor surface, contact your local dealer.

PREOPERATIONAL CHECKS

ITEMS TO BE CHECKED

1 CHECK THE RESULT OF REPAIRS PERFORMED ON PREVIOUS CHECKING

CAUTION

Never try to operate a faulty truck.

Check to see if any defect found on the previous inspection has been repaired properly.

2 TIRE INFLATION PRESSURE AND TIRE CONDITION CHECK

CAUTION

The tires of the lift truck have a high inflation pressure. Make sure the tires and rims are normal and inflate the tires to the standard air pressure. Do not overinflate the tires.

When using an air compressor to inflate the tires, first adjust the compressor air pressure properly. Failure to do so will cause a serious accident since the compressor delivers the maximum pressure.

A small bend of the rim or a slightly damaged tire might cause a flat tire, leading to a serious accident. If you find any failure, contact your local dealer.

Keep the inflation pressure of the tires always at proper level.

NOTE

Low air pressure reduces tire service life. Unevenness of air pressure between right and left tires will cause hard steering or the truck to wander.



The standard tire pressure is indicated on the decal at the left side of the front guard.

Front wheels (both single and double tires)	700 kPa (7 kg/cm ²)
Rear wheels 2- to 4-ton	700 kPa (7 kg/cm ²)

Turn the tire valve cap counterclockwise and remove it. Using a tire pressure gauge, measure the inflation pressure and adjust for the standard inflation pressure. Then, make sure there is no air leakage from the tire valve, re-install the tire cap.

Check that each tire does not get damaged at the tread surface or side face or bending at the rim.

The lift truck needs tires that have a high inflation pressure for carrying heavy loads.

PREOPERATIONAL CHECKS

HUB NUT CHECK

CAUTION
 A loose hub nut can be dangerous. In the worst case, the wheel comes off the truck, causing the truck to tip over.

Check the hub nuts for looseness. All hub nuts should be tightened to the specified torque.

HUB NUT TIGHTENING TORQUE

Unit: N-m (kgf-m)

	Front wheels (Single tire)	Rear wheels
2- to 2.5-ton trucks	471-549 (48-56) The double-tire specification is the same.	128 - 190 (13 - 19.4)
3-to 4-ton trucks	471-549 (48-56) The double-tire specification is the same.	

Tightening order for double nuts

Double tires are installed by locking the inner tire rim with inner hub nuts (square nuts) and then by locking the outer tire rim with outer hub nuts (hex. nuts).

First, tighten the inner nuts (square nuts) in a diagonal order to the specified torque and then tighten the outer nuts (hex. nuts) in the same manner as above.

Tightening drive shaft mounting bolts (nuts)

If any loose bolt or nut is found, retighten it to the following torque :

96 -11 N-m (9.8 -11.3 kgf-m)

CAUTION
 Do not use tires whose bolts securing the split type rim assembly are loose.
 The front single tires and rear tires use split type rim assembly in which the inner and outer rims are bolted together. If any tire has a loose rim connecting bolt, do not operate the truck.
 Remove the air valve core to remove the air from the tire and detach the tire from the truck. (For more information about the procedure for removing the tire, see page 4-25.)
 Loosen the split rim connecting bolts using a special tool. It is advisable to ask a special to retighten the connecting bolts, disassemble and reassemble the tire and rim, and inflate the tire. (The disassembly, reassembly and inflation of tires should be performed only by qualified personnel.)

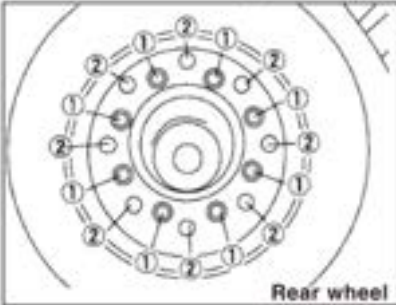
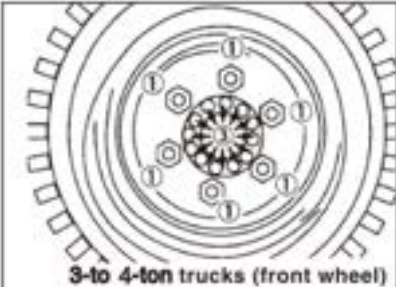
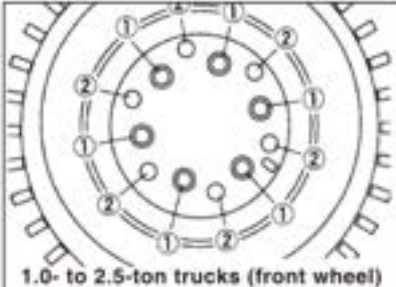

- ① Hub nuts
- ② Rim connecting bolts
- ③ Drive shaft mounting bolts

PREOPERATIONAL CHECKS

3 OVERHEAD GUARD

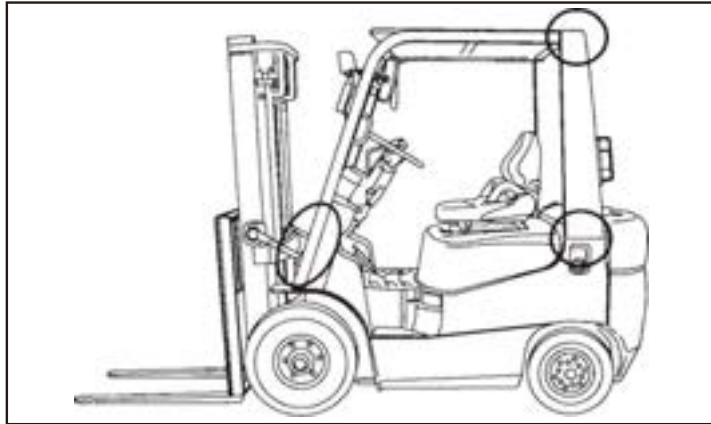

Check the overhead guard for loose mounting bolts or nuts or damage.

4 BRAKE FLUID LEVEL (excl. trucks with power brake)

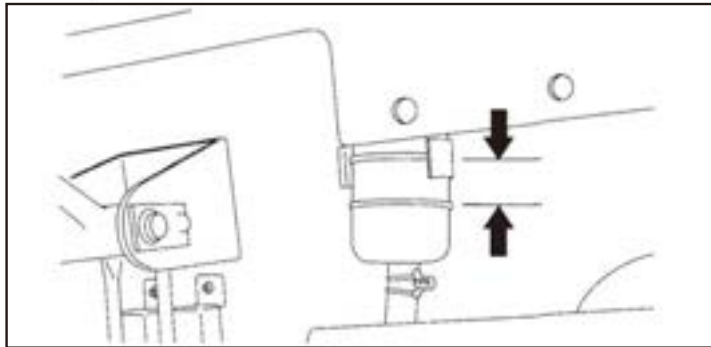

You can check the brake fluid level from outside the reservoir tank, without having to remove the tank cap.
Make sure the fluid level is as specified.

Open the engine hood



CAUTION

Pull the hood opening lever and open the hood fully. Make sure the hood is locked securely and remove your hand.

5 BATTERY ELECTROLYTE LEVEL



CAUTION

- Do not use or charge the battery with the electrolyte level below the "LOWER LEVEL" otherwise the inside of the battery deteriorates to cause a short battery life and in the worst case it might cause an explosion. Never use
- open flame for checking the electrolyte level. There is a danger of causing an explosion.

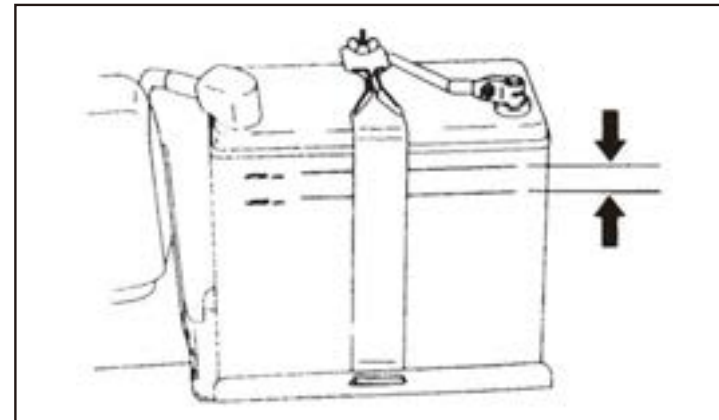

PREOPERATIONAL CHECKS

6 COOLING WATER LEVEL

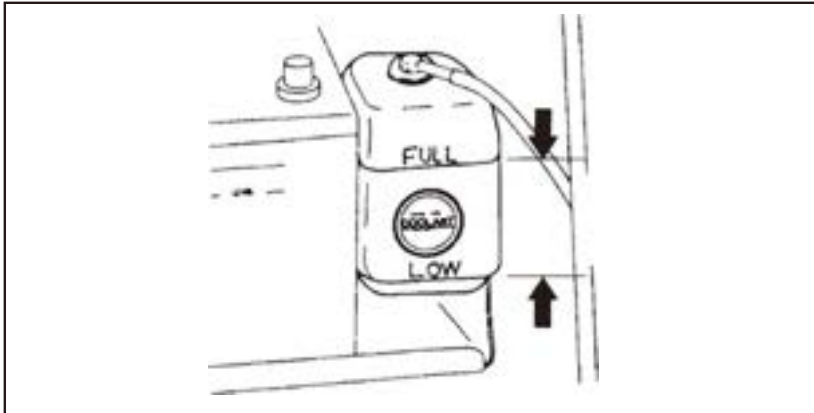

Check the cooling water level when the radiator is cold. Make sure that the cooling water level between "FULL" and "LOW" markings on the cooling water reservoir tank. If addition of cooling water is needed, remove the reservoir tank cap and add clean (soft) water.

REMOVING RADIATOR CAP

⚠ CAUTION

Do not try to remove the radiator cap when the engine is hot; otherwise you will get burnt. The cooling water level should be checked before starting the engine or when the engine is cold.

When removal of the radiator cap is needed, observe the following conditions:

- **Release the pressure before removing the cap**
There is a pressure inside the radiator. First, loosen the cap by turning it counterclockwise a little to release the pressure, and then remove the cap.
- **Use caution not to get burnt**
When releasing the pressure, use a thick waste cloth. (Avoid putting on gloves since you may get burnt at your hand if hot water splashes on it. Do not peep into the filler port. It is dangerous.)

PREOPERATIONAL CHECKS

7 ENGINE OIL LEVEL

CAUTION

The exhaust system is hot immediately after the engine is shut down. Use caution not to get burnt.

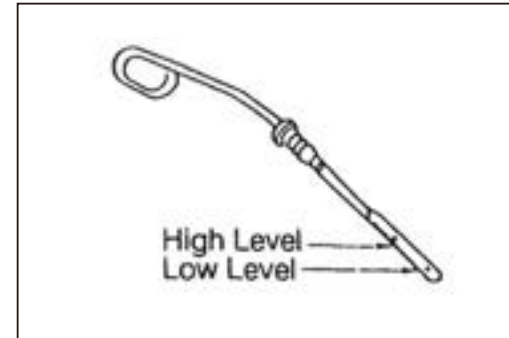
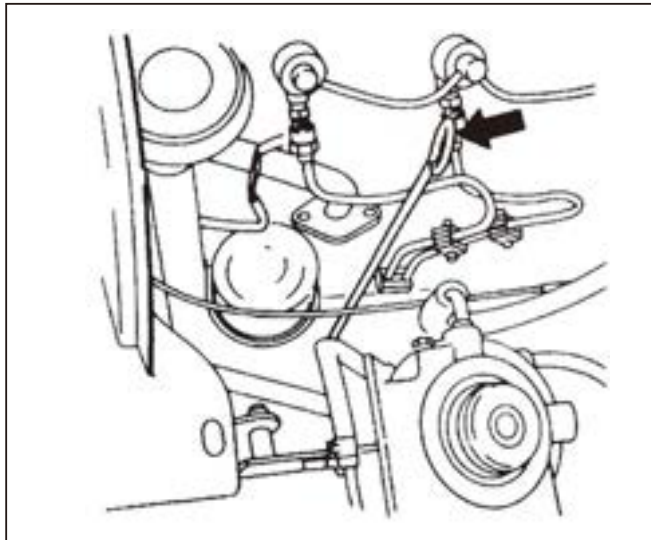

The engine oil level dipstick is located at the left side of the engine. Remove the dipstick, clean the rod and reinstall. Pull it out again and check the oil level. The level should be within the range between the High and Low marks on the dipstick. Do not add engine oil above the High mark on the dipstick.

NOTE

Engine oil level check should be performed with the truck parked on a level surface before starting the engine. You cannot know the correct oil level immediately after the engine is shut down. Wait for about 10 minutes before checking the oil level.

PREOPERATIONAL CHECKS

8 FAN BELT

CAUTION
Make sure the engine is shut down before checking the fan belt for tension.

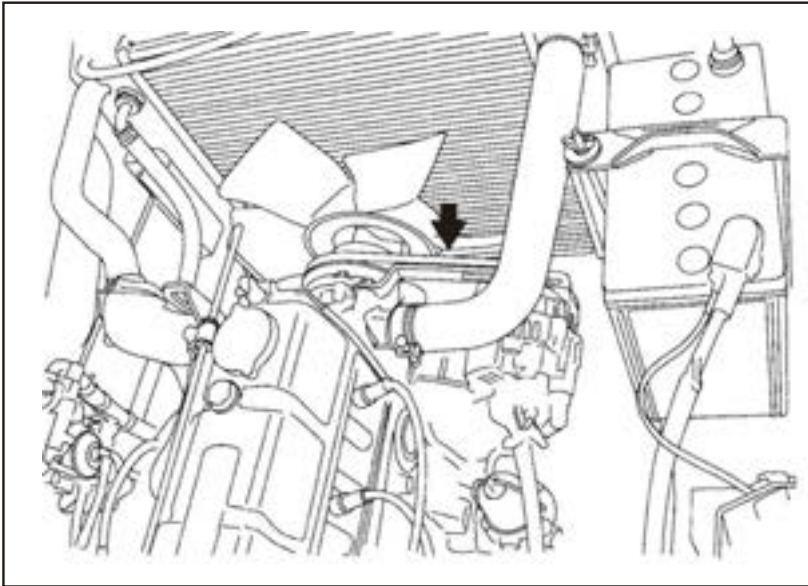

Check the fan belt for proper tension and cracks or damage.

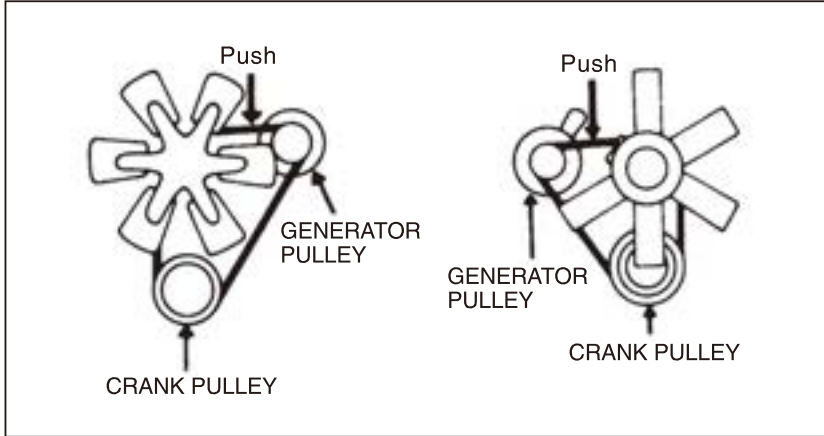

WARNING
Keep fingers or objects away from fan when engine is running.

PREOPERATIONAL CHECKS

9 REAR COMBINATION LAMP

Check the rear combination lamps (turn signals, tail lamps, brake lamp, back-up lamp, and rear reflector) for a damaged or contaminated lens.

10 HYDRAULIC OIL LEVEL

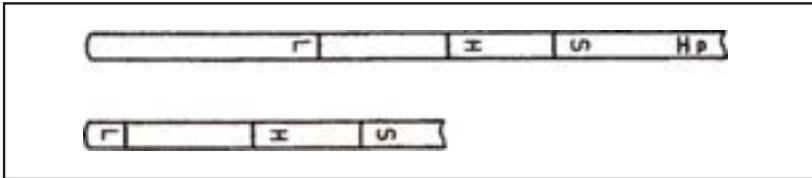

Check the hydraulic oil level in the tank using the oil level dipstick. Remove the dipstick, clean the rod with a clean cloth and reinsert it. Remove the dipstick again and check the oil level. If the level is low, add hydraulic oil.

"H" mark: Highest position of the standard truck

"L" mark: Lowest position of the standard truck

"S" mark: For trucks with a lift height of 6m or more or for special trucks, the oil level should be within 10 mm above or below this mark.

"HP" mark: Use this mark for 2- to 4-ton trucks with high-power specification.

NOTE

The oil level check should be performed with the engine shut down, the mast vertical, the forks on the ground or floor surface, and the truck parked on a level surface.

11 HYDRAULIC OIL PIPING AND CYLINDERS

Visually check the hydraulic oil piping and lift and tilt cylinders for oil leaks.

12 TORQUE CONVERTER OIL LEVEL (T TYPE)

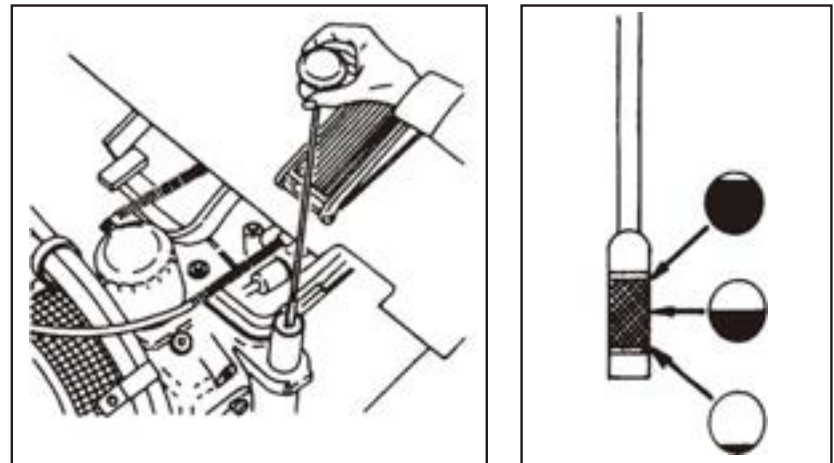

The torque converter oil filler cap is located under the floorboard. Remove the oil dipstick of the filler cap. Clean the rod with a clean cloth and reinstall it. Remove the dipstick again and check the oil level. The oil level should be within the specified range. If the level is low, add oil.

PREOPERATIONAL CHECKS

13 LOAD BACKREST

CAUTION

- Do not modify or remove the load backrest.
- The operator might get injured by a falling load.
- The forks might come off the carriage.

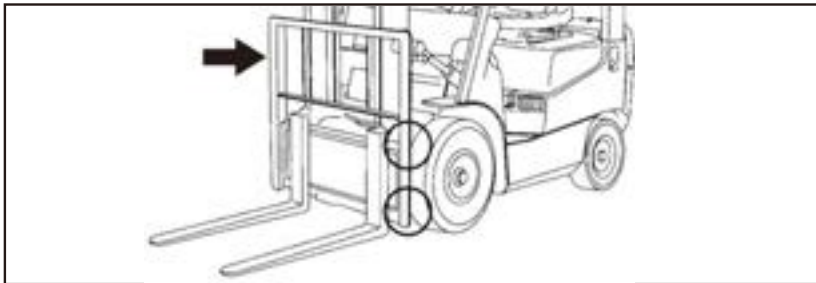

Check the load backrest for damage or loose or missing mounting bolts.
Retighten where needed.

14 FORKS AND FORK STOPPERS

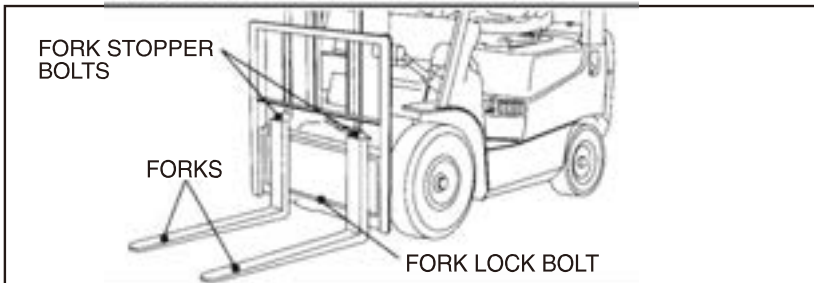

Check that the fork stopper are properly engaged, the fork lock bolt at the middle of the carriage is not damaged, the forks are not bent and do not have cracks.

15 HEAD LAMPS AND COMBINATION LAMPS

Check for dirty or damaged lens of the head lamps. Check also the combination lamps (clearance lamps and turn signals) for a dirty or damaged lens.

Close the engine hood

CAUTION

Take care not to pinch your fingers in the hood.

16 ADJUSTING DRIVER'S SEAT AND STEERING COLUMN ANGLE

Get on the truck and adjust the driver's seat to a position which provides easy access to all foot and hand controls. Also make sure you can operate After the adjustment of the driver's seat position and steering column angle, lock the seat and steering column securely.

17 SIDEVIEW MIRRORS

Check the sideview mirrors for contamination or damage. Adjust the mirrors to gain full rearview when you are seated in the driver's seat.

PREOPERATIONAL CHECKS

18 SHIFT LEVERS

Check the direction and speed range shift levers (C type) and shift lever (T type) for looseness and smooth operation.

19 LOAD HANDLING LEVERS

CAUTION

Note that the forks drop when the lift lever is pushed forward even if the engine is not running.

Check the load handling levers (lift, tilt and attachment) for looseness and smooth operation.

20 PARKING BRAKE OPERATION

Pull the parking brake lever to check if the parking brake is properly applied.

Start the engine

CAUTION

Make sure the shift levers are in neutral "N" and the parking brake is applied before starting the engine.

21 WARNING LIGHTS

turn the starter switch from "OFF" to "ON" Make sure the warning lights come on in red and go out soon after the engine has started.

22 FUEL LEVEL

Check the fuel level using the fuel level gauge on the meter panel. Make sure the fuel level is sufficient for the day's work or for each shift. In addition, if the truck is equipped with a water temperature gauge or oil temperature gauge, check it, too, for proper operation.

23 LIGHTS AND LAMPS

Operate the lighting switch to check if the lights and lamps come on and off properly.

24 TURN SIGNALS

Operate the turn signal lever to see if the turn signals blink normally.

25 HORN

Press the horn at the center of the steering wheel to check if the horn sounds properly.

PREOPERATIONAL CHECKS

26 CLUTCH PEDAL (C TYPE)

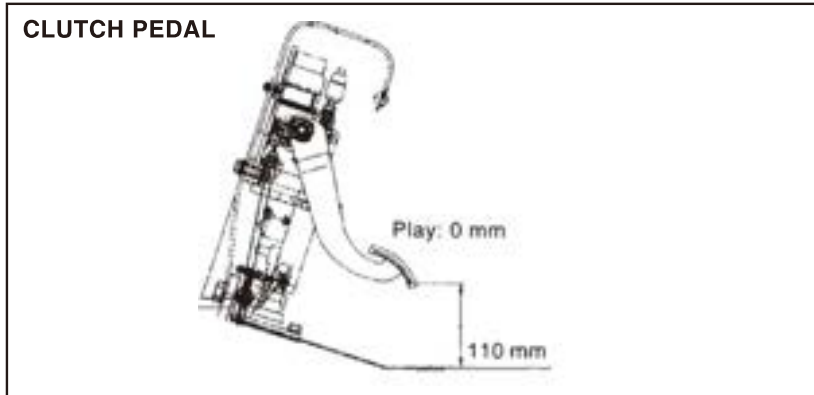

Press the clutch pedal to check if it operates smoothly. Release the pedal to check if it returns securely.
(For trucks with power clutch, start the engine before checking the clutch pedal.)

27 BRAKE AND INCHING PEDALS

⚠ CAUTION

If the pedal returns poorly or the pedal height is not as specified, check the return spring and take necessary measures. If neglected, the pedal might become locked, making it difficult to press.

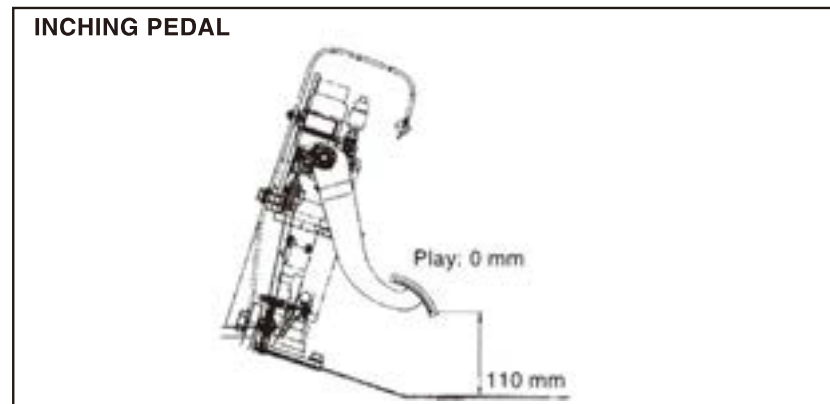
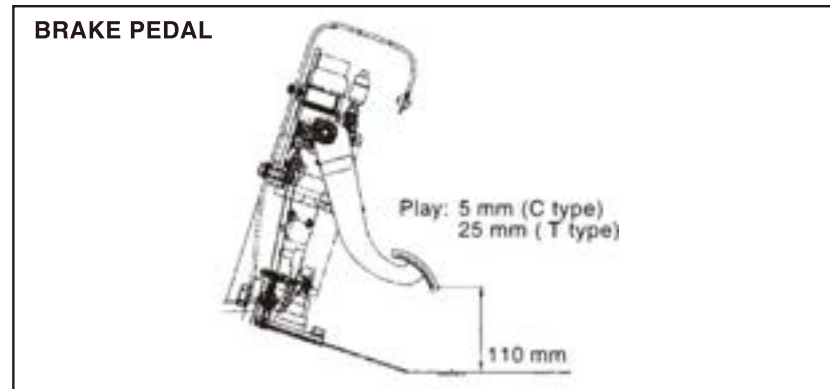

PREOPERATIONAL CHECKS

Press the brake pedal and inching pedal (T type) to check if the pedal can be pressed smoothly and returns securely. Check the brake pedal and inching pedal for play (see the sketches).

28 MAST OPERATION

Operate each of the lift and tilt levers to check if the forks and mast operate smoothly without squeaking. Check also each lever for looseness. (If the truck is equipped with a hydraulic attachment, check the attachment itself and its control lever.)

NOTE

WARMING UP CYLINDERS

Before starting the day's work, warm up the cylinders. This lubricates packings and seals in the cylinders to make them ready for operation.

29 LIFT CHAIN TENSION

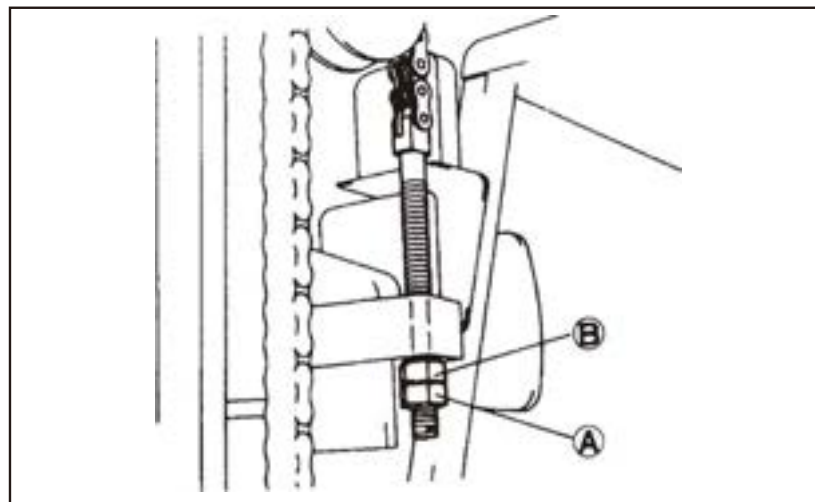

Raise the forks 50 mm(1.96 in) off the ground or floor surface and check

that the right and left lift chains have the same tension. If uneven tension is found, adjust the tension using the adjusting nut (B) of the chain anchor bolt. After adjustment, securely tighten the lock nut (A)

PREOPERATIONAL CHECKS

30 STEERING WHEEL

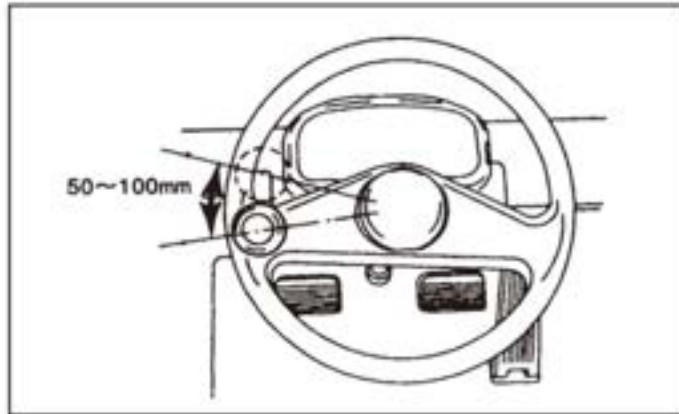

Turn the steering wheel counterclockwise and clockwise to check for play.
The normal play is within the range of 50 to 100 mm(1.9 to 3.9 in), Check also for vertical looseness.

31 EXHAUST GAS CONDITION

⚠ CAUTION

- Exhaust fumes are very dangerous. When starting the lift truck in an enclosed space, make sure there is enough ventilation. The exhaust gas check should be done outdoors.
- Especially use caution to avoid fire hazards. Pay special attention to signs of oil or fuel leaks, and never leave waste cloth or paper inside the engine room, Make sure you know where the fire extinguishers are kept and how to use them.

Check the condition of exhaust gas after the engine has been warmed up.

Colorless or light blue: Normal (Complete combustion)

Black: Abnormal (Incomplete combustion)

White: Abnormal (Oil burns)

Check also the engine for abnormal noise or vibration.

PREOPERATIONAL CHECKS

Run the truck at a low speed (at an out-of-traffic area)

32 CLUTCH PEDAL OPERATION TEST (C TYPE)

Run the truck slowly and press the clutch pedal for proper operation.

Run the truck slowly and press the inching pedal (T type) a little to check if the truck slows down.

33 BRAKE TEST

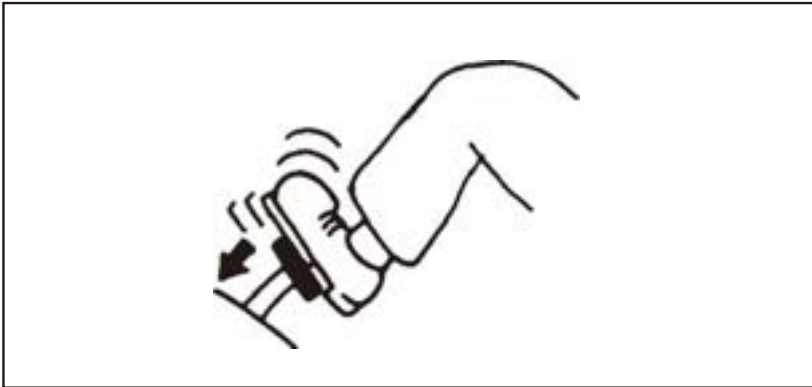

Run the truck slowly and press the brake pedal to check if the truck is braked properly without being pulled to one side.

Make sure the brake lamps come on when the brake pedal is pressed.

PREVENTIVE MAINTENANCE

34 STEERING TEST

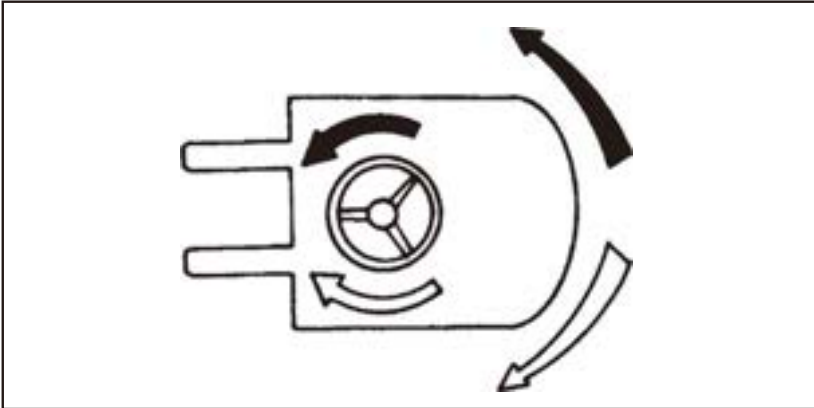

Run the truck at a low speed and turn the steering wheel a little to the right and left to check if the truck is steered properly.

35 PARKING BRAKE TEST

Pull the parking brake lever to check if the truck is properly braked. Also make sure the truck does not move and keeps its stopping position.

36 BACK-UP LIGHT AND ALARM TEST

Check that the back-up lamp comes on and alarm sounds when the shift lever is shifted into reverse "R".

PREVENTIVE MAINTENANCE

AIR BLEEDING FUEL SYSTEM

DIESEL ENGINE TRUCKS

CAUTION

- Make sure there is not any fuel leak from the air bleeding plug port. If any, there is a danger of causing a fire hazard.
- Wipe away any split fuel from areas around the air bleeding plug. There is a danger of causing a fire hazard.

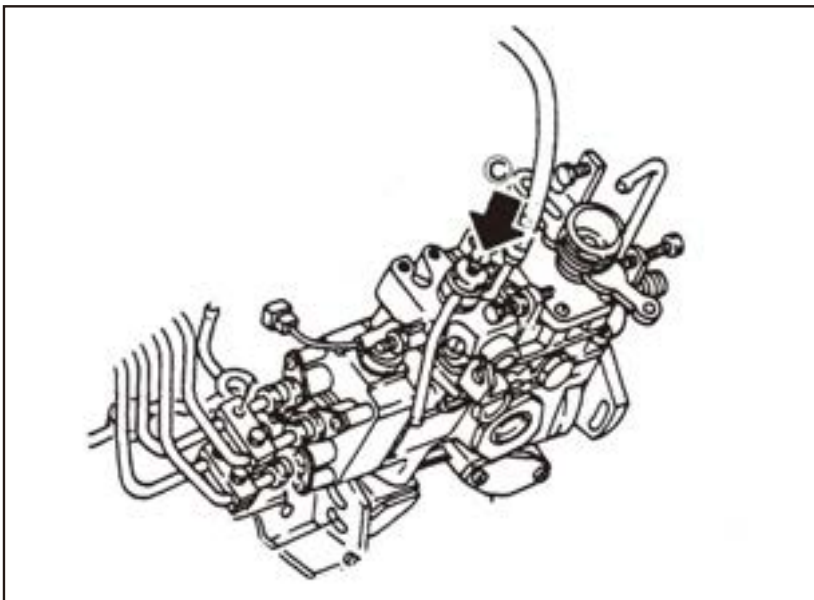

Whenever the fuel filter is replaced or the fuel tank is drained, air bleed the fuel system in the following manner:

4-18

490BPG

- 1) Loosen the air bleeding plug (overflow valve) of the injection pump.
- 2) Loosen the priming pump of the sedimenter and pump the priming pump until the fuel coming from the plug hole is free from bubbles.
- 3) Reinstall the air bleeding plug securely.
- 4) Tighten the priming pump securely.

PREVENTIVE MAINTENANCE

REPLACING FUSES

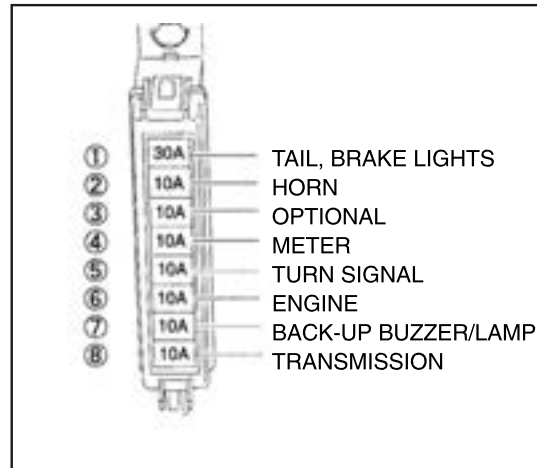
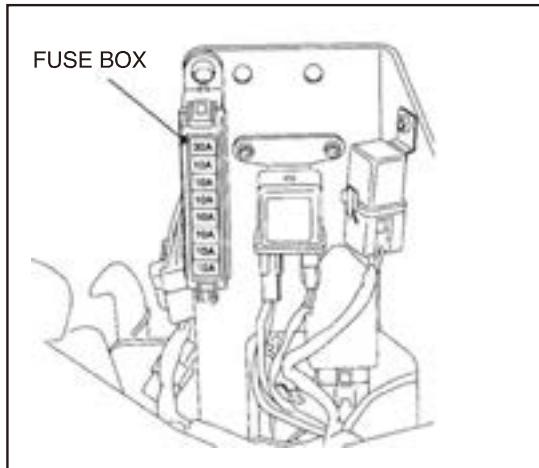

FUSIBLE LINK (MAIN FUSE)

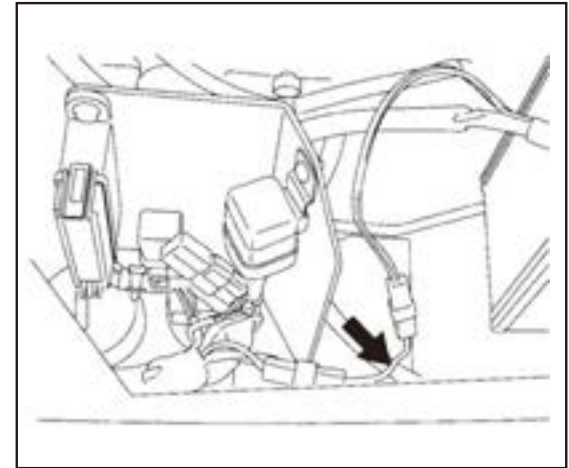

Check to see that the components in each circuit are operating properly. If every component in a circuit is not functioning, it indicates that the corresponding fuse is blown out. Replace the blown fuse with a spare fuse of the same capacity and color. If some of the components in a circuit do not function properly, it suggests that a bulb has burnt out. Replace the burnt bulb with a new one of the same capacity.

- ① - ③: They function regardless of the key switch position.
 ④ - ⑧: They function when the key switch is in "ON".

As the main fuse for the entire truck, a fusible link wire (red cable) is provided at the positive (+) side of the battery. If the entire electrical circuit of the truck does not function, replace this fusible link wire with a new one.

NOTE

The fuses protect the electric circuit against overcurrent. Use fuses of the specific ampere rating.

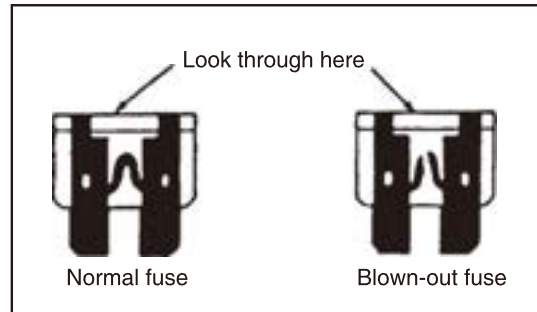

PREVENTIVE MAINTENANCE

REPLACING TIRES AND REPAIRING FLAT TIRE

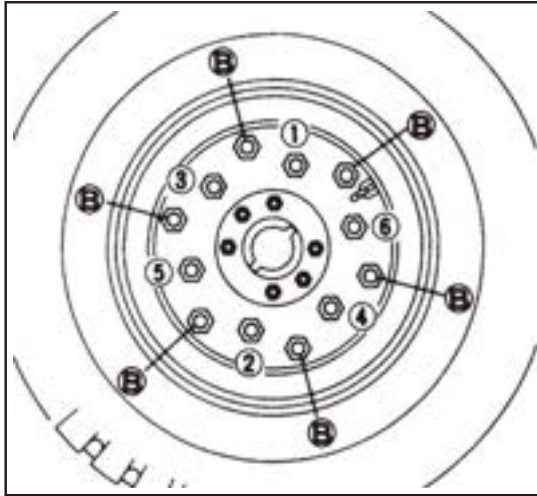

Get tools and jack necessary for replacing tires.

Frontwheel

CAUTION

When removing a tire from the truck, remove air from the tire completely and then remove the hub nuts.

- 1) Park the truck on a level, hard surface and shut down the engine. Do not have any load on the forks.
- 2) Apply the parking brake and block the

- 3) Jack up the truck to an extent that the tire still remains on the ground. Loosen the hub nuts (① - ⑥). Do not remove them yet.
- 4) Jack up the truck until the tire leaves off the ground. Remove the hub nuts.
- 5) Remove the tire from the hub.
- 6) When reinstalling the tire, use the reverse order of removal. Tighten the hub nuts in a diagonal order and evenly. Hub nut tightening torque: See page 4-5. After installing the tire to the truck, adjust the inflation pressure to the standard inflation pressure, if needed.

Rear wheel

Proceed in the same manner as with the front wheel tire, except that the position of the jack goes under the counterweight. Hub nut tightening torque: See page 4-4.

 **WARNING**



AVOID SEVERE INJURY OR DEATH
Tire servicing requires special training. Do not take tires off truck until all air pressure is out. Loosen only WHEEL LUG NUTS "A".

Do not loosen wheel assembly nuts "B" until all air pressure is out of tire. See OPERATORS MANUAL for more important instructions for wheel service and reassembly.

Make sure all nuts and bolts are in place and tight.

Never add air to a tire that looks low. Let all air out and check for proper assembly. Inflate all tires in a safety cage. See MANUAL for proper pressures.



Split-type



Safety cage

PREVENTIVE MAINTENANCE

Remove a tire from the rim

⚠ CAUTION

- Before removing a tire from the rim, remove the valve core to release the air pressure from the tire completely. In the case of the split type rim, remove air from the tire before loosening the split rim connecting bolt (B); in the case of the side ring type rim, remove air from the tire before removing the side ring (lock ring).
- The assembling of a tire, tube, rim, and flap and inflating of a tire which has been removed from the truck should be done only by qualified personnel. The lift truck uses tires which have an inflation pressure far higher than those of general passenger cars. The use of improper parts or work procedure will cause a serious accident. Tires should be inflated with them attached to the truck or by putting in a safety cage, even if you are qualified to inflate tires.
- The split rim connecting bolts must be tightened to the specified torque using the special tool, with the tire inflation pressure removed completely.
- Install the split rim on the truck with the rim connecting bolt head pointing outside.

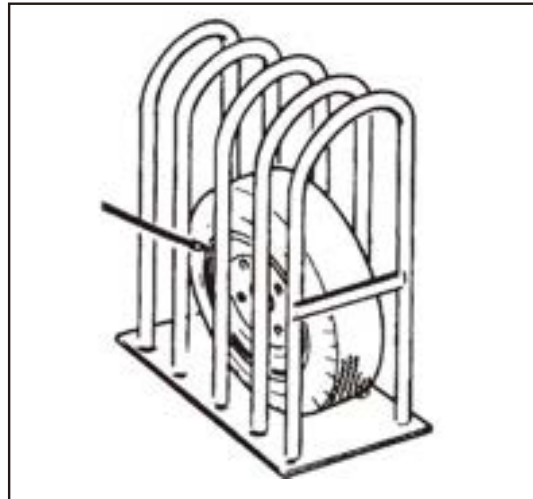
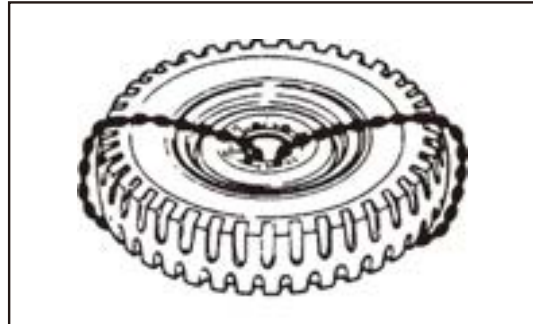

REPLACING LAMP BULBS

If any light bulb burns out, replace it with a new one of the same capacity, referring to the following table:

Lamp capacity

1. Head lamp	12V-55W
2. Clearance lamp	12V-10W
3. Turn signal	
Front	12V-27W
Rear	12V-23W
4. Tail lamp	12V- 8W
5. License number plate	
lamp (option)	12V-10W
6. Rear work light	
(option)	12V-55W
7. Brake lamp	12V-23W
8. Back-up lamp	12V-10W
9. Meter panel light	14V-1.4W

PREVENTIVE MAINTENANCE

WHEN YOU CANNOT START THE ENGINE BECAUSE THE BATTERY HAS BEEN EXHAUSTED

⚠ WARNING

Do not push or tow the truck to jump start it when the battery is exhausted. While the engine is not running, power steering and power brake are inoperative.

When the battery has been exhausted, use an auxiliary battery to start the engine.

CAUTION TO BE TAKEN WHEN STARTING ENGINE WITH AUXILIARY BATTERY

⚠ WARNING

When starting the engine using an auxiliary battery, make sure to connect the (-) cable finally. Connect the cable to a point away from the battery, such as either of the two tilt cylinders, but not to the (-) terminal of the battery. This will help prevent the occurrence of sparks which might cause a fire.

STARTING WITH AUXILIARY BATTERY

⚠ CAUTION

- Keep the booster cable in place while the starter motor is turning; otherwise sparks occur to cause an accident.
- Never allow the (+) terminal of the booster cable to come in contact with the (-) terminal of the booster cable.

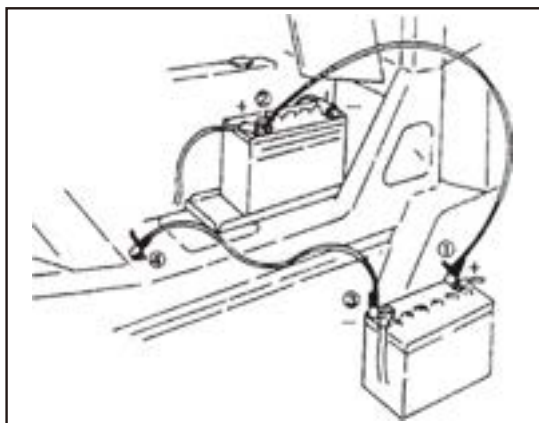

- 1) Make sure that the auxiliary battery supplies 12V.
- 2) Connect the booster cables in the following order:
 - ① Connect red cable (+) to the (+) terminal of the auxiliary battery.

- ② Connect the red cable (+) to the (+) terminal of the battery on the truck.
- ③ Connect the black cable (-) to the (-) terminal of the auxiliary battery.
- ④ Connect the black cable (-) to the (-) terminal of the frame at a point away from the battery on the truck, such as to either of the two tilt cylinders.

3) Start the engine.

📖 NOTE

For more information, see "STARTING ENGINE AND AFTER ENGINE HAS STARTED" on page 3-6.

- 4) After the engine has started, remove the booster cables in the reverse order of connection.

ADJUSTING OPERATING FORCE OF PARKING BRAKE

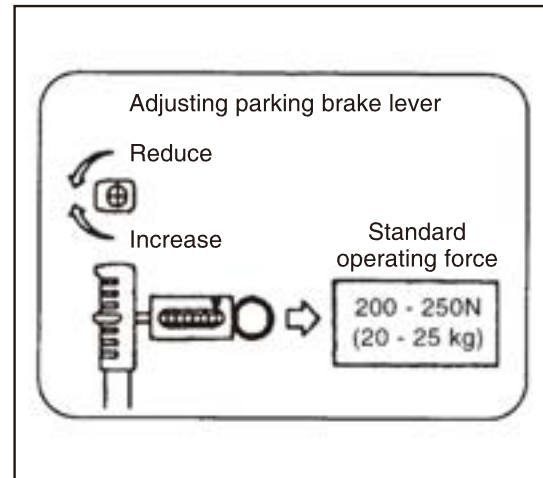
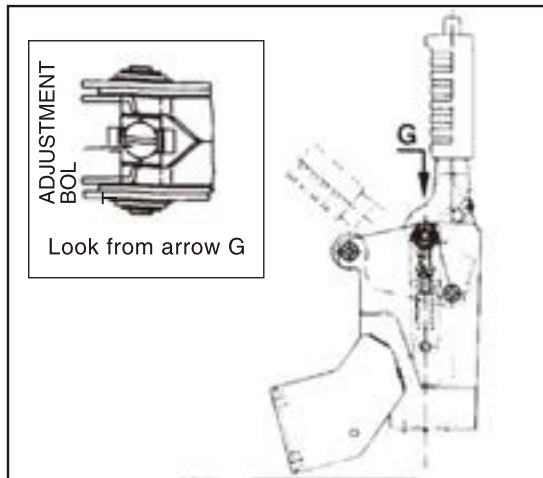

ADJUSTMENT

- 1) Engage the spring scale to the parking brake lever as shown above and measure the force required to operate the lever.

**Standard operating force: 200 - 250 N
(20 - 25 kg).**

- 2) If the measurement is not within the range of the standard operating force, turn the adjustment bolt with a screwdriver to adjust the operating force of the lever.

Reduce by turning the bolt counterclockwise.

Increase by turning the bolt clockwise.

- 3) The cable of a new truck tends to elongate. It is advisable to adjust it sometimes after the day's work or each shift.

PERIODIC INSPECTION

Just as your body needs to undergo physical examinations, your truck needs periodical checks and maintenance.

When the truck appears to be in good condition, checks and maintenance are likely to be neglected. But early discovery of trouble which may decrease truck efficiency and immediate correction, will greatly increase the working capacity of the truck, bring about greater productivity, prolong its life span and make it more economical.

Preoperational checks, the addition of oil, grease and fuel, and cleaning of filter elements should be carried out by the customer and other complicated checks and maintenance should be left to your dealer. If enough knowledge, special tools or equipment is not available, personal injury could occur during checking or servicing. In this manual, the periodic inspection intervals are indicated as the number of months (years) as well as operating hours. Every one month of operation is calculated as 200 operating hours.

 **CAUTION**

Be sure to read INSPECTION AND MAINTENANCE in this manual before checking or servicing the truck.

PERIODICAL REPLACEMENT OF SAFETY PARTS

In order to perform safe operation, the importance of preventive maintenance of the truck cannot be overemphasized. Especially, the parts listed in the table below must be replaced periodically since they are the most important parts for safety of the truck and operator. Moreover these safety parts are liable to be damaged and deteriorated in the course of time, and it is difficult to determine by ordinary maintenance whether they are beyond their respective service limits or not. The safety parts must be replaced with new ones when their respective service limits have been reached, even if their appearances are good.

 **NOTE**
The safety parts are, however, not the objects of warranty claim.

	Name of safety parts	Replacement interval (year)
1	Master cylinder and wheel cylinder cups and dust seals	1
2	Power cylinder hose	2
3	Reservoir tank tubing	2 - 4
4	Fuel hose	2 - 4
5	Torque converter hose	2
6	Rubber parts inside the power steering unit	2
7	Lift chain	2 - 4
8	Load handling means hose	1 - 2

PERIODIC INSPECTION

MONTHLY (200 OPERATING HOURS) CHECKS

Perform preoperational checks in addition to the following.

The adjustment and replacement of components and parts listed as monthly check items are difficult and need a sufficient technical knowledge and special tools.

Items to be checked
<ul style="list-style-type: none">● Air cleaner - Clean element.● Engine oil - Change [1 week (50 operating hours) for the first time only].● Cylinder head bolt - Retighten (gasoline engine trucks, for the first time only).● Fuel filter - Check for clogging (gasoline engine trucks).● Cooling system rubber hose - Check for deterioration.● Radiator cap - Check for function and proper installation.● Shift levers - Check for proper operation and looseness.● Torque converter and transmission - Check oil level.● Front axle - Check for oil leak.● Front axle mount bolt - Check for looseness.● Tire tread - Check for wear or foreign matter.● Front and rear axles - Check for deformation, cracks or damage.● Steering gear box - Check for oil leak.● Rod, arm and king pin - Check for looseness, warping or damage.● Rear axle - Check for proper installation.● Clutch booster - Check master cylinder oil level (trucks with power clutch)● Clutch booster - Check piping, master cylinder and release cylinder for oil leak.● Oil clutch - Check oil level in the tank (trucks with optional oil clutch).

Items to be checked

- Brake piping – Check for the entrance of air.
- Brake system rods and cables – Check for proper operation and looseness.
- Brake piping – Check for damage, leaks, intervention or looseness.
- Brake fluid – Check for leaks.
- Forks – Check for cracks or wear.
- Mast – Check for cracks or damage.
- Mast support – Check cap bolts (first time only)
- Lift cylinders – Check for looseness of tail fixing bolts, piston rod head mounting bolts, cylinder U bolts and piston head guide mounting bolts (first time only).
- Carriage – Check for cracks or damage.
- Mast rollers – Check loose rollers, cracked or damaged roller pins.
- Lift chain – Check for elongation.
- Lift chain – Lubricate.
- Lift chain and anchor pin – Check for looseness.
- Sheaves and sheave bearings – Check for deformation, damage or looseness.
- Attachment – Check for proper operation and installation.
- Control valve – Check for proper operation of relief valve and tilt lock valve.
- Battery – Check electrolyte level and clean.
Wire harness – Check for damage or loose clamp.
- Chassis – Lubricate.

■ LUBRICATING LIFT CHAIN

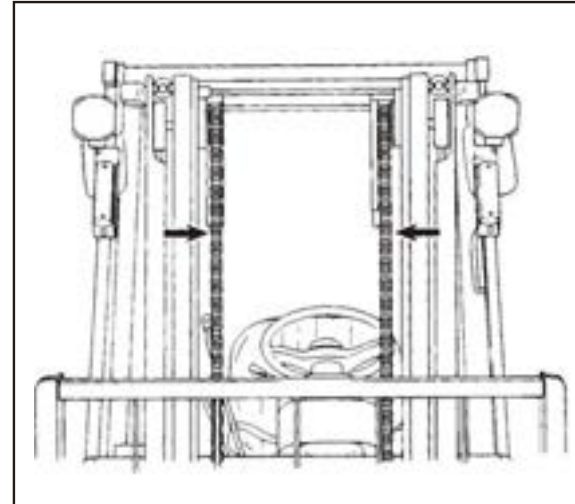

Apply engine oil to the lift chains using an oiler or brush. To allow oil to enter between each pin and link plate of the lift chain, observe the following conditions:

- 1) Loosen the chain sufficiently.
- 2) After applying engine oil, move the mast up and down at least 10 times.



NOTE

If your lift truck is used near a port or coastal area, the lift chains might be damaged from salty breezes. After a storm or typhoon, it is advisable to wash them with water before lubricating in the above manner.

PERIODIC INSPECTION

GREASING POINTS

MAST AND STEERING SYSTEM

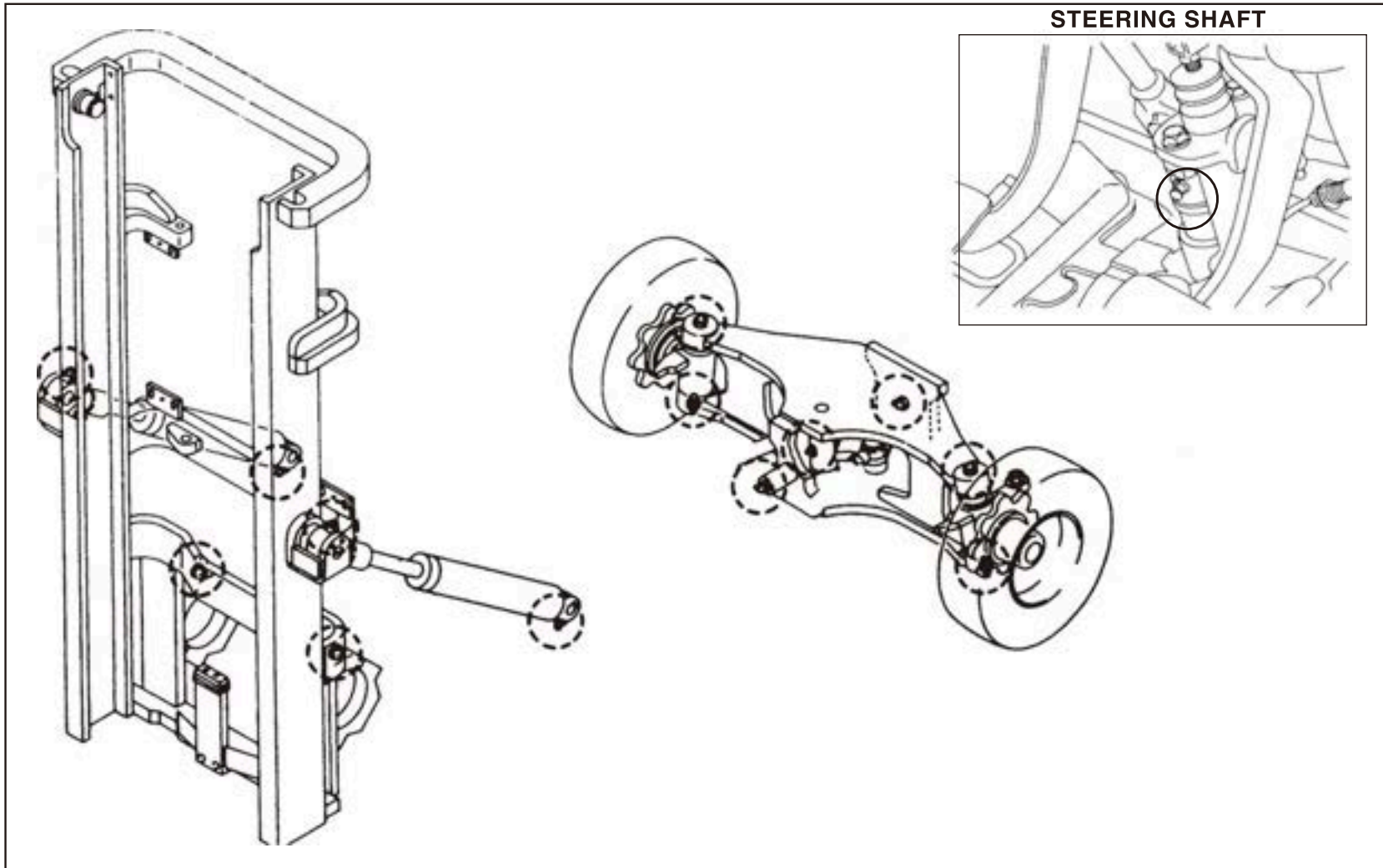

CLUTCH RELEASE YOKESHAFT (C TYPE)

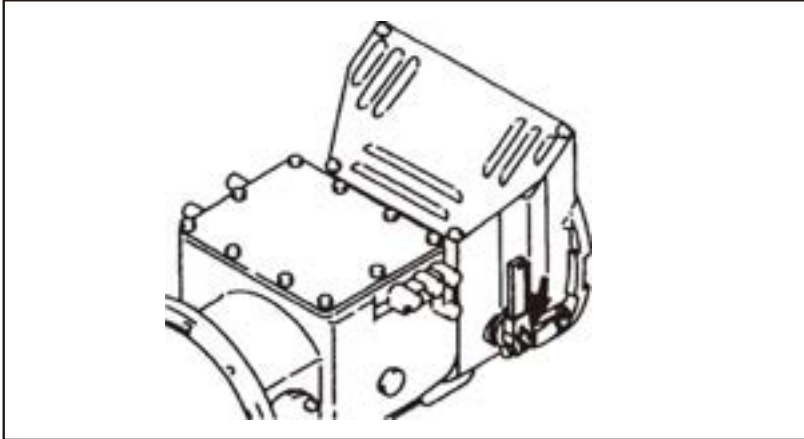

MAST REAR SLIPPER (FOR OPTIONAL MAST)

⚠ CAUTION

Do not climb the mast. Do not pour your hand or foot on the connecting members or into the mast assembly. You might get injured if the mast moves accidentally.

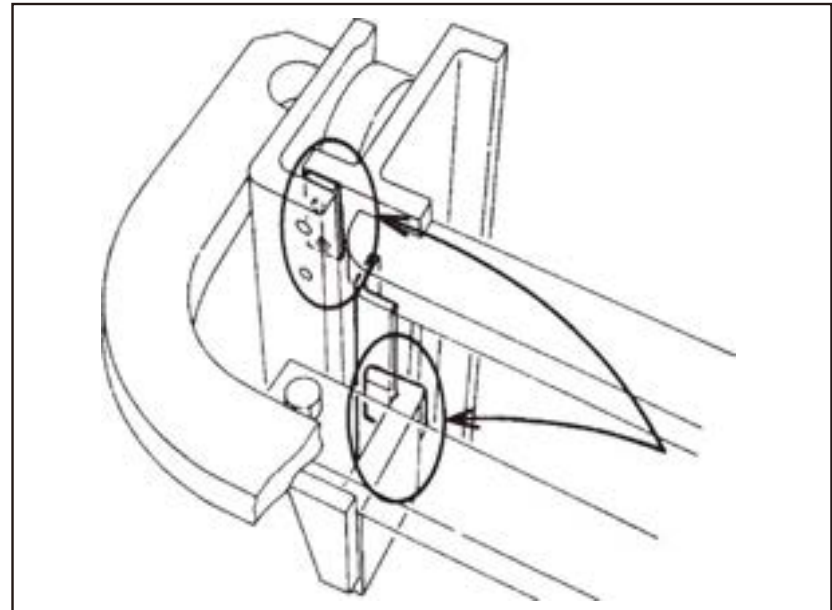

Apply grease on the U-shape guides shown in the sketch (for masts with free lift mechanism)

PERIODIC INSPECTION

■ CHECKING AIR CLEANER ELEMENT

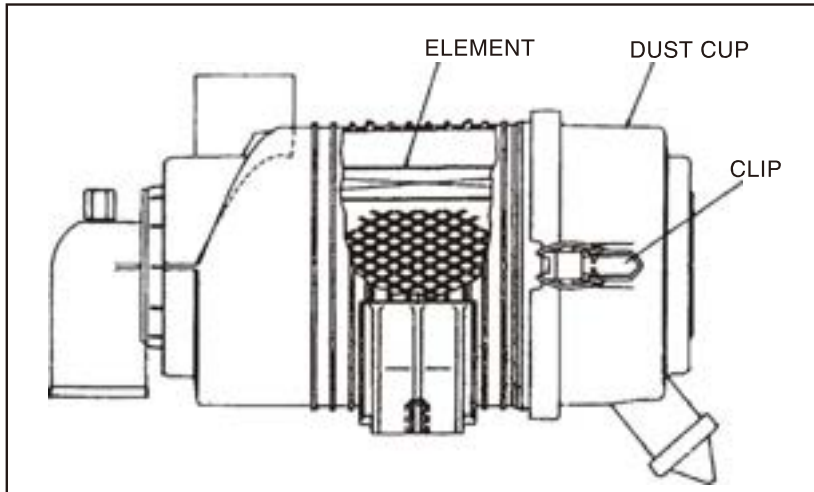

Open the engine hood and disengage the air cleaner case clip and remove the element.

Check the element for contamination or damage. Also check the rubber seal for cracks or contamination.

Cleaning element

CAUTION

When using compressed air, wear safety glasses.

To clean the element, blow compressed air from inside out or tap lightly by hand.

Also check for a rupture or pin holes in the element.

Clean the element once a month (200 hours of operation) and change with a new one every 6 months (1200 hours of operation)

Removing the element

Remove the two (or three) clips of the case and remove the wing nut securing the element. Then you can take the element out.

■ CHANGING ENGINE OIL

CAUTION

Do not drain waste oil into a waterway nor throw it away on the ground. Disposal of waste oil should be left to a specialist, dealers will undertake oil change job, if required.



Change the engine oil once a month (200 hours of operation). However, for new trucks, the engine oil should be changed at the first 50 hours or after one week.

CAUTION

**Do not try to change the engine oil immediately after the engine is shut down.
The engine oil is very hot. Change the engine oil when the oil is properly warm.**

Before changing engine oil

When the engine is cold, start the engine and let it run at low rpm to warm it up.

Then, move to a level surface and push in the parking brake button to park the truck and remove the key. Open the engine hood fully.

PERIODIC INSPECTION

3 MONTHS (600 OPERATING HOURS) CHECKS

Perform the following checks in addition to preoperational checks and one month (200 operating hours) checks.

Items to be checked
<ul style="list-style-type: none">• Cooling water – Change (every 2 years for trucks using LLC).• Crankcase – Check the air breather for contamination and clean if necessary.• Engine oil filter – Change (200 hours for first time only).• Fuel filter – Change (diesel engine trucks).• Fuel tank – Drain water.• Fork stopper pins – Check for damage or wear.• Starter – pinion gear – Check for proper engagement.• Charger – Check for proper operation.• Battery – Check the specific gravity of the electrolyte.• Electrical wiring – Check for loose connections.

CHANGING FUEL FILTER

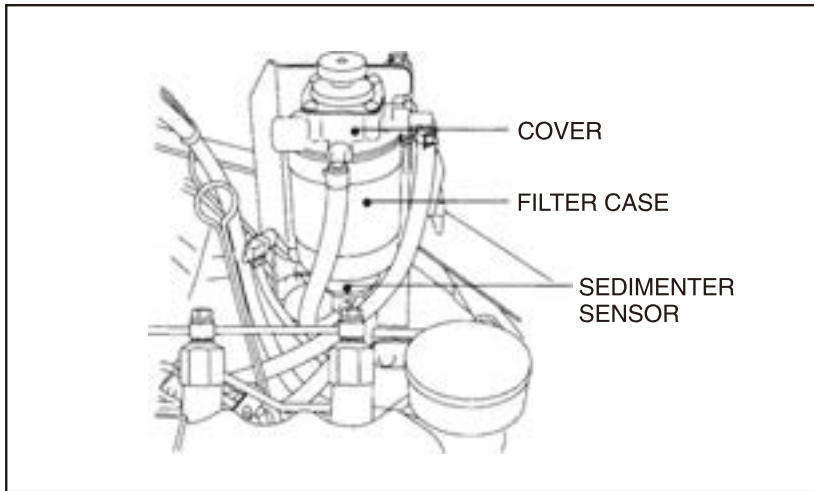

Using a filter wrench, remove the filter case from the cover. Remove the sedimentor sensor from the bottom of the filter case. Attach the sedimentor sensor to a new filter case and install the filter case into the cover.

- Sedimentor sensor tightening torque: 12-14 N·m (120 - 140 kg·m)
- Filter case mounting torque: 12 - 14 N · m (120 - 140 kg·m)

PERIODIC INSPECTION

CHANGING ENGINE OIL FILTER

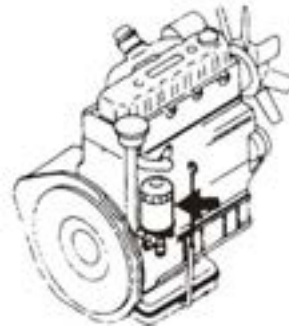

⚠ CAUTION

The engine is very hot immediately after the engine is shut down,. Change the engine oil filter after the engine cools down enough.

Change the engine oil filter in the following manner:

- 1)Using a filter wrench, loosen the filter cartridge and remove.
- 2)Get a new filter cartridge.
- 3)Wipe clean the cylinder block in the cartridge mounting area.
- 4)Apply a thin coat of engine oil on the gasket of the new filter cartridge.
- 5)Hand tighten the new filter cartridge. After the gasket touches the seal surface, use a filter wrench to tighten the cartridge.

- 6)Make sure there is no oil leak from the filter mounting area. (Add engine oil to the specified level, start the engine and run it at idle rpm for a while.)

👉 NOTE

- In general, the engine oil filter should be changed for every two changes of engine oil.
- When removing the filter cartridge, engine oil might spill over the floor. Put an oil receiving pan or cloth. (The filter cartridge holds about 0.54 liters of oil.)

PERIODIC INSPECTION

6MONTHS (1200 OPERATING HOURS) CHECKS

Perform the following checks in addition to daily checks, one month (200 operating hours) checks, and 3 months (600 operating hours) checks.

Items to be checked
<ul style="list-style-type: none">■ Air cleaner element – Change.■ Valve clearance – Check.■ Engine oil filter – Change.■ Injection nozzle – Check injection pressure and spray pattern.■ Clutch and brake fluid – Change.■ Fuel tank – Clean inside.■ Torque converter oil (engine oil or torque converter oil) and transmission oil (gear oil) – Change.■ Torque converter type transmission inline filter – Change (T type).■ Hydraulic oil tank suction filter – Clean.■ Hydraulic oil – Change.■ Front axle – Change oil.■ Front axle: – Check oil level.■ Wheel bearing – Check for looseness and noise.■ Wheel bearing – Change grease.■ Suction strainer – Change.■ Steering gear box – Check loose mounting bolt.■ Mast support – Check for loose cap bolt.■ Lift cylinder (of the view mast) – Check for looseness of cylinder tail fixing bolts, piston rod-to-connecting member bolts and cylinder fixing U bolts and retighten where necessary.■ Control valve – Measure relief pressure.■ Driver's seat – Check for damage and loose mounting bolts.

PERIODIC INSPECTION

REPLACING TRANSMISSION INLINE FILTER (T TYPE)

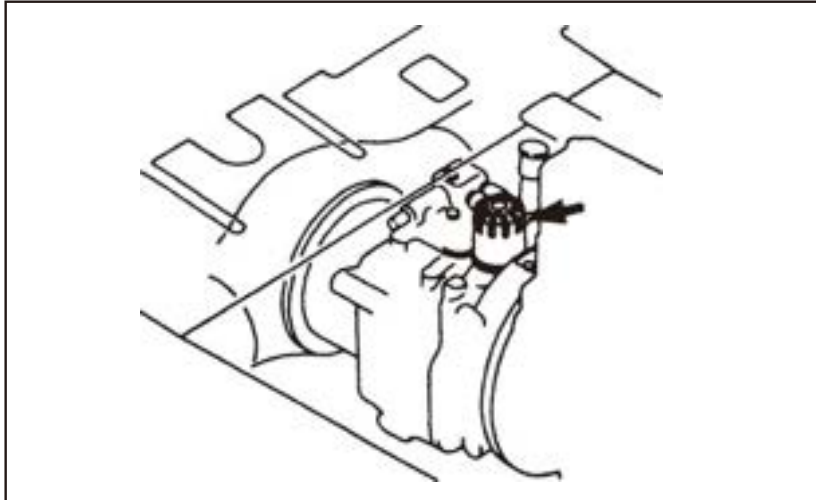

Shut down the engine and release the pressure from the power transmission line. Remove the filter cartridge shown above and replace it with a new one. Apply a coat of engine oil to the packing of the new filter cartridge and install the filter cartridge by hand tightening. After the packing touches the seat, hand tighten the filter securely.

The filter cartridge should be replaced with a new one at the initial 200 hours of operation and thereafter every 1200 hours of operation.

PERIODIC INSPECTION

ANNUAL(2400OPERATINGHOURS) CHECKS

Perform the following checks in addition to daily checks, one month (200 operating hours) checks, and 3 months (600 operating hours) checks, and 6 months (1200 operating hours) checks.

Items to be checked
<ul style="list-style-type: none">■ Cylinder head bolts – Retighten (C240 engine)■ Cylinder – Measure compression pressure.■ Injection timing – Check.■ Governor – Check proper operation (maximum rpm under unloaded condition).■ Clutch retainer bearing – Lubricate.■ Clutch oil tank (trucks with optional oil clutch) – Change clutch oil and clean strainer.■ Parking brake – Check for proper operation, wear and damage.■ Master cylinder and wheel cylinder – Check for proper operation, oil leaks and damage.■ Master cylinder and wheel cylinder – Change piston cup and check valve.■ Wheel brake – Disassemble, check, adjust and change brake drum and brake shoe.■ Mast support – Check bushings for wear or damage .■ Hydraulic pump drive – Check for wear.■ High-voltage cable – Check for breakage.■ Main frame and cross members – Check for damage, cracks, loose rivets or bolts.

PERIODIC INSPECTION

PREVENTIVE MAINTENANCE SCHEDULE

This maintenance schedule is worked out on the assumption that the lift truck will be used under typical working conditions. If the lift truck is used under severer working conditions, earlier preventive maintenance is required. (The black dots in the table mean "Change or addition".)

POWER TRAINS

Checking item	Service Required	Tools	Daily	Monthly (200 hrs)	Trimonthly (600 hrs)	Semiannually (1200 hrs)	Annually (2400 hrs)
Engine	Visually check for proper rotation	Visual	○	○	○	○	○
	Check working noise	Auditory	○	○	○	○	○
	Check exhaust gas (color)	Visual	○	○	○	○	○
	Check air cleaner element for contamination and clean, if needed	Visual		○	○	●	●
	Check crankcase air breather for contamination and clean, if needed	Operate			○	○	○
	Check valve clearance	Thickness gauge				○	○
	Retighten cylinder head bolts	Torque wrench					
	Check cylinder compression pressure	Compression gauge					○
Governor	Check maximum speed under unloaded condition	Tachometer					○
Lubrication system	Check for engine oil leaks	Visual	○	○	○	○	○
	Check engine oil for level and contamination	Visual	○	○	○	○	○
	Change engine oil	Operate		● (at initial 50 hrs)	°C	●	●
	Change engine oil filter	Operate		● (first time only)	°C	●	●

PERIODIC INSPECTION

POWER TRAINS

Checking item	Service Required	Tools	Daily	Monthly (200 hrs)	Trimonthly (600 hrs)	Semiannually (1200 hrs)	Annually (2400 hrs)
Fuel system	Check for fuel leaks (piping, pump tank).	Visual	○	○	○	○	○
	Check for fuel filter for clogging.	Visual			○	○	○
	Clean fuel filter.	Operate			○	○	○
	Change fuel filter element.	Visual			●	●	●
	Check injection nozzle for injection pressure and spray pattern.	Nozzle tester				○	○
	Check injection timing	Operate					○
	Clean the inside of fuel tank.	Visual				○	○
	Check fuel level.	Visual	○	○	○	○	○
Cooling system	Check cooling water level.	Visual	○	○	○	○	○
	Check for water leaks.	Visual	○	○	○	○	○
	Check rubber hose for deterioration.	Visual		○	○	○	○
	Check radiator cap for proper function and installation.	Visual		○	○	○	○
	Clean and change water.	Operate			●	●	● (every 2 years when LLC is used.)
	Check fan belt for proper tension and damage.	Visual	○	○	○	○	○

PERIODIC INSPECTION

POWER TRAINS

Checking item	Service Required	Tools	Daily	Monthly (200 hrs)	Trimonthly (600 hrs)	Semiannually (1200 hrs)	Annually (2400 hrs)
Clutch	Check clutch pedal for play and the clearance between pedal and floorboard when disengaged.	Operate and scale	○	○	○	○	○
	Check for noise and proper disengagement.	Operate	○	○	○	○	○
	Check for slipping and proper engagement.	Operate	○	○	○	○	○
	Check master cylinder and release cylinder for fluid leaks and change fluid.	Operate		○	○	●	●
	Check the function of booster (trucks with power clutch).	Operate	○	○	○	○	○
	Check booster for oil leaks (trucks with power clutch).	Operate	○	○	○	○	○
	Check clutch oil level in tank of trucks with optional oil clutch (Clean strainer whenever oil is changed.)	Visual		○	○	○	●
Transmission	Check shift levers for operation and looseness.	Operate				○	○
	Check for oil leaks.	Visual	○	○	○	○	○
	Check oil level and change oil if necessary.	Operate				●	●
Torque converter type transmission	Check for oil leaks.	Visual	○	○	○	○	○
	Change oil.	Visual		○	○	●	●
	Check shift lever for operation and looseness.	Operate		○	○	○	○
	Check control valve and clutch for proper function.	Operate	○	○	○	○	○
	Check inching valve for function.	Operate	○	○	○	○	○
	Check inching pedal for play and travel.	Operate	○	○	○	○	○
	Change inline filter and element.	Operate			● (first time only)		●
Front axle	Check for oil leaks.	Visual	○	○	○	○	○
	Change oil.	Visual				●	●
	Check for loose mount bolt.	Visual		○	○	○	○

PERIODIC INSPECTION

STEERING SYSTEM

Checking item	Service Required	Tools	Daily	Monthly (200 hrs)	Trimonthly (600 hrs)	Semiannually (1200 hrs)	Annually (2400 hrs)
Tire	Check inflation pressure	Tire gauge	○	○	○	○	○
	Check for cracks or damage	Visual	○	○	○	○	○
	Check tread depth	Depth gauge		○	○	○	○
	Check for undue wear	Visual	○	○	○	○	○
	Check for debris, stones or foreign matter in tread	Visual		○	○	○	○
Hub, rim mounting bolt, nut	Check for looseness	Test hammer	○	○	○	○	○
	Check for damage	Visual	○	○	○	○	○
Rim, side ring	Check rim, side ring, and disk wheel for damage	Visual	○	○	○	○	○
Wheel bearing	Check for looseness or noise	Touch		○	○	○	○
	Disassemble and change grease	Operate				●	●
Axle	Check for deformation, cracks or damage	Visual		○	○	○	○

CONTROLS

Checking item	Service Required	Tools	Daily	Monthly (200 hrs)	Trimonthly (600 hrs)	Semiannually (1200 hrs)	Annually (2400 hrs)
Steering wheel	Check for play.	Operate	○	○	○	○	○
	Check for looseness in axial direction.	Touch	○	○	○	○	○
	Check for looseness in radial direction.	Touch	○	○	○	○	○
	Check for proper operation.	Operate	○	○	○	○	○
Steering gear box	Check for loose mounting bolt.	Operate		○	○	○	○
Rod, arm	Check for looseness.	Operate		○	○	○	○
	Check for bending, damage or wear	Visual		○	○	○	○

PERIODIC INSPECTION

CONTROLS

Checking item	Service Required	Tools	Daily	Monthly (200 hrs)	Trimonthly (600 hrs)	Semiannually (1200 hrs)	Annually (2400 hrs)
Knuckle	Check king pin for looseness or damage.	Touch		<input type="radio"/>	<input type="radio"/>	<input type="radio"/>	<input type="radio"/>
Rear axle	Check for bending, damage or wear.	Visual		<input type="radio"/>	<input type="radio"/>	<input type="radio"/>	<input type="radio"/>
	Check mounting condition.	Test hammer		<input type="radio"/>	<input type="radio"/>	<input type="radio"/>	<input type="radio"/>
Power steering	Check for proper operation.	Operate	<input type="radio"/>	<input type="radio"/>	<input type="radio"/>	<input type="radio"/>	<input type="radio"/>
	Check for oil leaks.	Visual	<input type="radio"/>	<input type="radio"/>	<input type="radio"/>	<input type="radio"/>	<input type="radio"/>
	Check for loose mounting or linkage.	Visual		<input type="radio"/>	<input type="radio"/>	<input type="radio"/>	<input type="radio"/>

BRAKE SYSTEM

Checking item	Service Required	Tools	Daily	Monthly (200 hrs)	Trimonthly (600 hrs)	Semiannually (1200 hrs)	Annually (2400 hrs)
Brake pedal	Check for play.	Scale	<input type="radio"/>	<input type="radio"/>	<input type="radio"/>	<input type="radio"/>	<input type="radio"/>
	Check for pedal height and returning.	Scale	<input type="radio"/>	<input type="radio"/>	<input type="radio"/>	<input type="radio"/>	<input type="radio"/>
	Check for braking or uneven braking.	Operate	<input type="radio"/>	<input type="radio"/>	<input type="radio"/>	<input type="radio"/>	<input type="radio"/>
	Check for the entrance of air into braking piping.	Operate		<input type="radio"/>	<input type="radio"/>	<input type="radio"/>	<input type="radio"/>
	Check booster for proper function and oil leaks (truck with power brake).	Operate	<input type="radio"/>	<input type="radio"/>	<input type="radio"/>	<input type="radio"/>	<input type="radio"/>
Parking brake lever	Check for proper operation and allowance.	Operate	<input type="radio"/>	<input type="radio"/>	<input type="radio"/>	<input type="radio"/>	<input type="radio"/>
	Check for braking effect.	Operate	<input type="radio"/>	<input type="radio"/>	<input type="radio"/>	<input type="radio"/>	<input type="radio"/>
Rod, cable	Check for proper operation.	Operate		<input type="radio"/>	<input type="radio"/>	<input type="radio"/>	<input type="radio"/>
	Check for loose linkage.	Touch		<input type="radio"/>	<input type="radio"/>	<input type="radio"/>	<input type="radio"/>
Hose and pipe	Check for damage, leaks or intervention.	Visual		<input type="radio"/>	<input type="radio"/>	<input type="radio"/>	<input type="radio"/>
	Check for loose connections or clamp.	Touch		<input type="radio"/>	<input type="radio"/>	<input type="radio"/>	<input type="radio"/>

PERIODIC INSPECTION

BRAKE SYSTEM

Checking item	Service Required	Tools	Daily	Monthly (200 hrs)	Trimonthly (600 hrs)	Semiannually (1200 hrs)	Annually (2400 hrs)
Oil brake	Check for fluid leaks (oil leaks for trucks with power brake).	Visual		○	○	○	○
	Check fluid level.	Visual	○	○	○	●	●
	Check master cylinder and wheel cylinder for proper operation.	Operate					○
	Check master cylinder and wheel cylinder for oil leaks or damage.	Visual					○
	Check master cylinder, piston cup and check valve for wear or damage, and replace if needed.	Disassembly					●
Brake drum and brake shoe	Check brake drum for loose installation.	Test hammer		○	○	○	○
	Check loose lining.	Vernier calipers					○
	Check brake shoe for operation.	Operate					○
	Check anchor pin for corrosion.	Visual					○
	Check return spring for deterioration.	Scale					○
	Check automatic clearance adjuster for operation.	Operate					○
	Check drum for wear or damage.	Visual					○
Back plate	Check for deformation.	Visual					○
	Check for cracks.	Visual					○
	Check loose installation.	Test hammer					○

PERIODIC INSPECTION

LOAD HANDLING SYSTEM

Checking item	Service Required	Tools	Daily	Monthly (200 hrs)	Trimonthly (600 hrs)	Semiannually (1200 hrs)	Annually (2400 hrs)
Forks	Check for damage, deformation or wear.	Visual	☉	☉	☉	☉	☉
	Check fork stopper pin for damage or wear.	Visual			☉	☉	☉
	Check for roots and teeth welded area for cracks or wear.	Visual		☉	☉	☉	☉
Mast and carriage	Check mast cross members for cracked weld or damage.	Visual		☉	☉	☉	☉
	Check tilt cylinder bracket and mast for cracks or damage in welded areas.	Visual		☉	☉	☉	☉
	Check outer and inner masts for cracked weld or damage.	Visual		☉	☉	☉	☉
	Check carriage for cracked weld or damage.	Visual		☉	☉	☉	☉
	Check roller bearing for looseness.	Touch		☉	☉	☉	☉
	Check mast support bushing for wear or damage.	Visual					☉
	Check mast support cap bolts for looseness.	Torque wrench		☉ (first time only)		☉	☉
	Check for looseness of lift cylinder tail bolts, piston rod head bolts, U bolts, piston head guide bolts.	Test hammer		☉ (first time only)		☉	☉
	Check rollers, roller pins and welds for cracks or damage.	Visual		☉	☉	☉	☉
Chains and sheaves	Check chains for tension, deformation, damage or corrosion.	Touch	☉	☉	☉	☉	☉
	Check chains for elongation.	Gauge		☉	☉	☉	☉
	Lubricate chains.	Operate		●	●	●	●
	Check loose linkage of chain anchor pin and chain.	Visual		☉	☉	☉	☉
	Check sheaves for deformation or damage.	Visual		☉	☉	☉	☉
	Check sheave bearings for looseness.	Touch		☉	☉	☉	☉
Attachments	Check for operation and installation.	Operate/visual		☉	☉	☉	☉

PERIODIC INSPECTION

LOAD HANDLING SYSTEM

Checking item	Service Required	Tools	Daily	Monthly (200 hrs)	Trimonthly (600 hrs)	Semiannually (1200 hrs)	Annually (2400 hrs)
Cylinder	Check piston rod, rod bolt, rod end for looseness, deformation or damage.	Visual/ test hammer	○	○	○	○	○
	Check for proper operation	Operate	○	○	○	○	○
	Check for oil leaks	Visual	○	○	○	○	○
	Check pin and cylinder bushing for wear or damage	Visual		○	○	○	○
Hydraulic pump	Check for oil leaks or noise	Visual & auditory	○	○	○	○	○
	Check drive for wear	Visual & auditory					○

HYDRAULIC SYSTEM

Checking item	Service Required	Tools	Daily	Monthly (200 hrs)	Trimonthly (600 hrs)	Semiannually (1200 hrs)	Annually (2400 hrs)
Hydraulic oil tank	Check oil level and change oil, if contaminated.	Visual	○	○	○	●	●
	Change suction strainer.	Operate				●	●
	Change return filter.	Operate				●	●
Control valve lever	Check for loose linkage of the lever.	Operate	○	○	○	○	○
	Check for function of the lever.	Operate	○	○	○	○	○
Control valve	Check for oil leaks.	Visual	○	○	○	○	○
	Check relief valve and tilt-lock valve for function.	Auditory		○	○	○	○
	Measure relief valve pressure.	Oil pressure gauge				○	○

PERIODIC INSPECTION

ELECTRICAL SYSTEM

Checking item	Service Required	Tools	Daily	Monthly (200 hrs)	Trimonthly (600 hrs)	Semiannually (1200 hrs)	Annually (2400 hrs)
Starter	Check proper engagement of pinion gears	Operate			○	○	○
Charger	Check for proper operation	Ammeter			○	○	○
Battery	Check electrolyte level and clean	Visual & auditory		○	○	○	○
	Check specific gravity of electrolyte	Gravimeter			○	○	○
Electrical wiring	Check wire harness for damage and loose clamp	Visual		○	○	○	○
	Check for loose connections	touch			○	○	○





PERIODIC INSPECTION

SAFETY DEVICE AND OTHERS

Checking item	Service Required	Tools	Daily	Monthly (200 hrs)	Trimonthly (600 hrs)	Semiannually (1200 hrs)	Annually (2400 hrs)
Overhead guard and load backrest	Check for loose mounting	Test hammer	○	○	○	○	○
	Check for deformation, cracks or damage	Visual	○	○	○	○	○
Turn signal	Check for operation and installation	Operate	○	○	○	○	○
Alarm	Check for operation and installation	Operate	○	○	○	○	○
Lights	Check for operation and installation	Operate	○	○	○	○	○
Back-up alarm	Check for operation and installation	Operate	○	○	○	○	○
Sideview mirrors	Check for contamination or damage	Visual	○	○	○	○	○
	Check for proper visibility	Visual	○	○	○	○	○
Meters	Check for operation	Operate	○	○	○	○	○
Rear reflector/ License number plate	Check for contamination or damage	Visual	○	○	○	○	○
Driver's seat	Check for damage or loose mounting bolts	Visual				○	○
Truck body	Check frame and cross members for damage or cracks	Test hammer					○
	Check for loose rivets and bolts	Visual					○
	Check the results of previous checks	Visual	○	○	○	○	○
	Check general condition of truck	Visual	○	○	○	○	○
Lubricants and oil change	After cleaning, check for lubrication of each part	Grease pump		●	●	●	●
	Check condition of lubricants	Check					○

The following symbols, found throughout this manual, alert you to potentially hazardous conditions to the owner and the operator. Become completely familiar with the truck before proceeding with operating, checking and servicing.

This manual and decals affixed to the truck use the following safety alert indications.

SIGNAL WORD	CLASSIFICATION
 DANGER	Failure to follow the instructions in the message will likely cause a serious accident or death.
 WARNING	Failure to follow the instructions in the message might cause a serious accident or death.
 CAUTION	Failure to follow the instructions in the message may cause personal injury or damage to the truck or other property.
 NOTE	The information will help to prolong the service life of the truck. The message is not directly related to accident prevention.

5. SPECIFICATIONS & SERVICE DATA

CONTENTS

SPECIFICATIONS.....	5 - 2
EQUIPMENT.....	5 - 5
LOAD CHART.....	5 - 6
SERVICE DATA.....	5 - 7
BOLT AND NUT TORQUE.....	5 - 8
REFILL CAPACITY.....	5 - 9
TRUCK SERIAL NUMBER.....	5-10
SERIAL NUMBERS OF MAJOR COMPONENTS	5-10
ENGINE SERIAL NUMBER.....	5-11
GENUINE TEU PARTS.....	5-12
GENUINE TEU LUBRICANTS	5-12
TRUCK DATA.....	5-13

SPECIFICATIONS

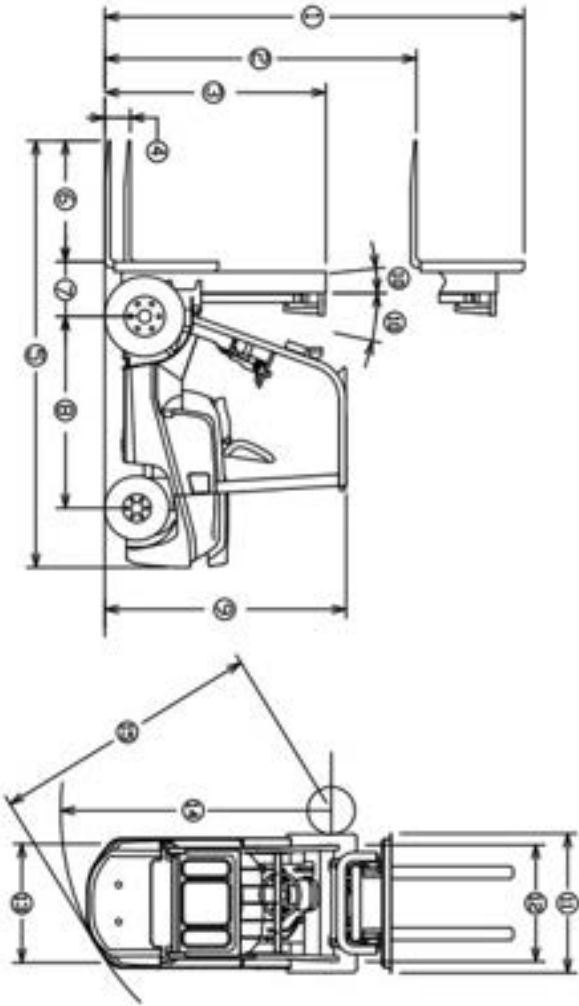

Specifications are subject to change without notice.

SPECIFICATIONS

Truck model		EK20D	EK20TLP	EK25D	EK25TLP	EK30/35D	EK30/35TLP	EK40D	EK40TLP
Leading particulars									
Rated load	kg/lb	2000/4000		2500/5000		3000/3500	6000/7000	4000/8500	
Basic load center	mm/in	500/24		←		←		←	
Max. height	A mm/in	3000/118		←		←		←	
Free liftFork	B mm/in	160/6.2		160/6.2		160/6.2		160/6.2	
lifting speed	mm/s in/s								
No load		580/22.8		←		470/18.5		480/18.8	
Loaded		550/21.6		←		450/17.7		380/14.9	
Traveling speed (fwd/rev)	km/h mph								
1st speed		8/5	19/11.8	←		8.5/5.3	19.5/12.1	16.5/10.3	
2nd speed		18.5/11.5	-	←		19.5/12.1	-	-	
Gradability (1.6 km/h)	%								
No load		20		18		20		←	
Loaded		21	27	18	23	15	18		
Min. turning radius	C mm/in	2170/85.4		2240/88.1		2400/94.4		2560/100.7	
Min. stacking aisle width	mm/in	1920/75.5		2010/79.1		2110/83		2220/87.4	
Overall length	D mm/in	3375/132.8		3600/141.7		3730/146.8		3890/153.1	
Overall width	E mm/in	1150/45.2		←		1225/48.2		1345/52.9	
Overall height (mast)	F mm/in	1995/78.5		←		2075/81.6		2150/84.6	
(overhead guard)	G mm/in	2070/81.4		←		2090/82.2		2140/84.2	
Overall height, mast raised	H mm/in	4030/158.6		←		4250/167.3		←	
Wheelbase	J mm/in	1600/62.9		←		1700/67		1800/70.8	
Tread, front	mm/in	970/38.1		←		970/38.1		1120/44	
rear	mm/in	970/38.1		←		←		970/38.1	
Fork size	mm/in								
length (K) x width (M) x thickness (N)		920X122X32 / 36.2X4.8X1.4		1070X122X40 / 42.1X4.8X1.5		1070X125X45 / 42.1X4.9X1.7		1070X150X50 / 42.1X5.9X1.9	
Fork spacing	P mm/in	245~1020 / 9.6~40.1		←		250~1090 / 9.8~42.9		300~1090 / 11.8~42.9	
Ground clearance (mast)	mm/in	110/4.3		←		140/5.5		←	
Weight	kg/lb	3330/7341		3670/8090		4310/9500		5100/11243	
Tire									
Front		7.00-12-12PR (I)				28 × 9-15-12PR (I)		2.50-15-16PR	
Rim size	L	5.00S-12DT				7.00T-15		7.50T-15	
Rear	cc	6.00-9-10PR (I)				6.50-10-10PR (I)		6.50-10-10PR	
Rim size	ps(kw)	4.00E-9DT				5.00F-10		5.00F-10	
Inflation pressure	kg.cm/rpm	700kPa (7.0kg/cm ²)				700kPa (7.0kg/cm ²)			

EQUIPMENT

Standard equipment

- ★ View mast
- ★ Forks (920mm for 2- ton type,
1070mm for 2.5-ton/3- ton type)
- ★ J-lug tire
- ★ Power steering
- ★ Overhead guard
- ★ Suspension seat with seat belt
- ★ Drawbar
- ★ Cyclone pack air cleaner
- ★ Parking brake lever (w. lock)
- ★ Dual valve (lift and tile) safety valve
- ★ Triple valve
- ★ Torque converter oil dipstick (T type)
- ★ Hydraulic oil dipstick
- ★ Cartridge filter (T type)
- ★ Cut-off valve
(Restricts the fork lowering speed if the
lift hose should burst.)
- ★ Tilt-lock valve (Prevents mast from tilt-
ing while engine is not running.)
- ★ Flow control valve
- ★ Halogen head lamp
- ★ Rear combination lamp
- ★ Rear/side view mirror
- ★ Back-up buzzer

- ★ Horn
- ★ Neutral switch
- ★ Floor mat
- ★ Engine hood damper stay
- ★ Upward air intake port
- ★ Radiator reservoir tank
- ★ Tilt steering wheel
- ★ Turn signal
- ★ Lamp guard
- ★ Hour meter
- ★ Engine water temp. gauge
- ★ Fuel gauge
- ★ Engine oil pressure gauge
- ★ Charge warning light
- ★ Glow plug indication light
- ★ Automatic glow plug unit
- ★ Key stop
- ★ Hand grip
- ★ Glove compartment with pen holder

Optional equipment

- ☆ Front double tires (w/ fender)
- ☆ Unique tire
- ☆ Steel cab (2- to 3-ton trucks)
- ☆ Steel cab (w./heater)
- ☆ Color tires (white, green)

- ☆ Speedometer
- ☆ Ammeter
- ☆ Spark prevention muffler (D)
- ☆ Exhaust purification muffler
- ☆ Upward-pointed tail pipe
- ☆ Fire extinguisher
- ☆ Tilt cylinder boot
- ☆ Steering cylinder boot
- ☆ Rear work light
- ☆ Yellow beacon light
- ☆ Overhead guard with wire netting
- ☆ Overhead guard canvas
- ☆ Paint color specified by the customer
- ☆ Triple (quadruple, quintuple) valves and
☆ piping
- ☆ Fishery specification
- ☆ Non-slip differential (2- to 3-ton T type)
Double-element air cleaner (2- to 2.5- ton
trucks)
- ☆ Pre-cleaner
- ☆ Plate-fin radiator
- ☆ Lifting eye

LOAD CHART

⚠ CAUTION

The load charts given below refer to lift trucks of standard specifications and those with high mast whose lifting height is less than 5 m. Note that load charts for lift trucks with a high mast whose lifting height is more than 5 m or those with an attachment have different load charts.

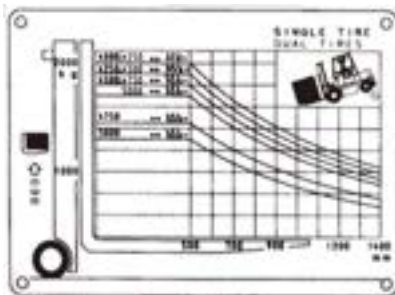

EK20D/TLP

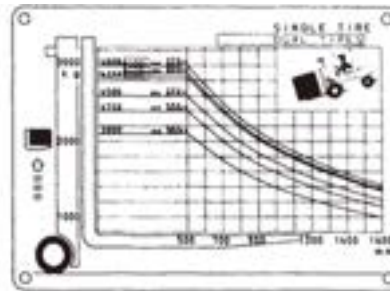

EK30D/TLP

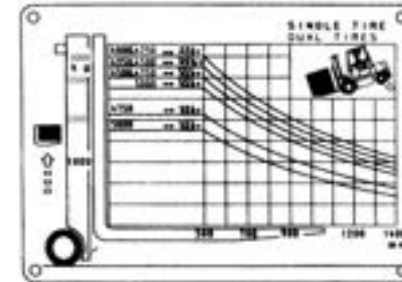

EK40D/TLP

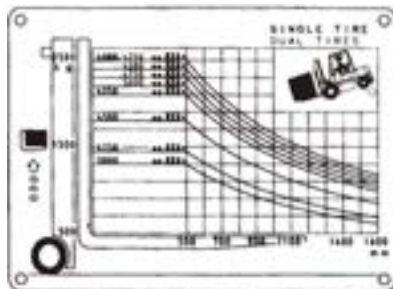

EK25D/TLP

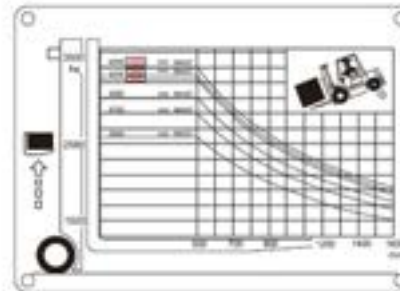

EK35D/TLP

SERVICE DATA

Tire inflation pressure:See page4-4.

Lift chain deflection:

.....No difference in deflection between both chains
are allowed when they are pressed with the
thumbs of both hands at the same time.

Steering wheel play:.....50-100 mm

Pedal settings:..... See page4- 12.

Hub nuts:..... See page 4- 5.

Drive shaft:..... Seepage 4- 5.

BOLT AND NUT TORQUE

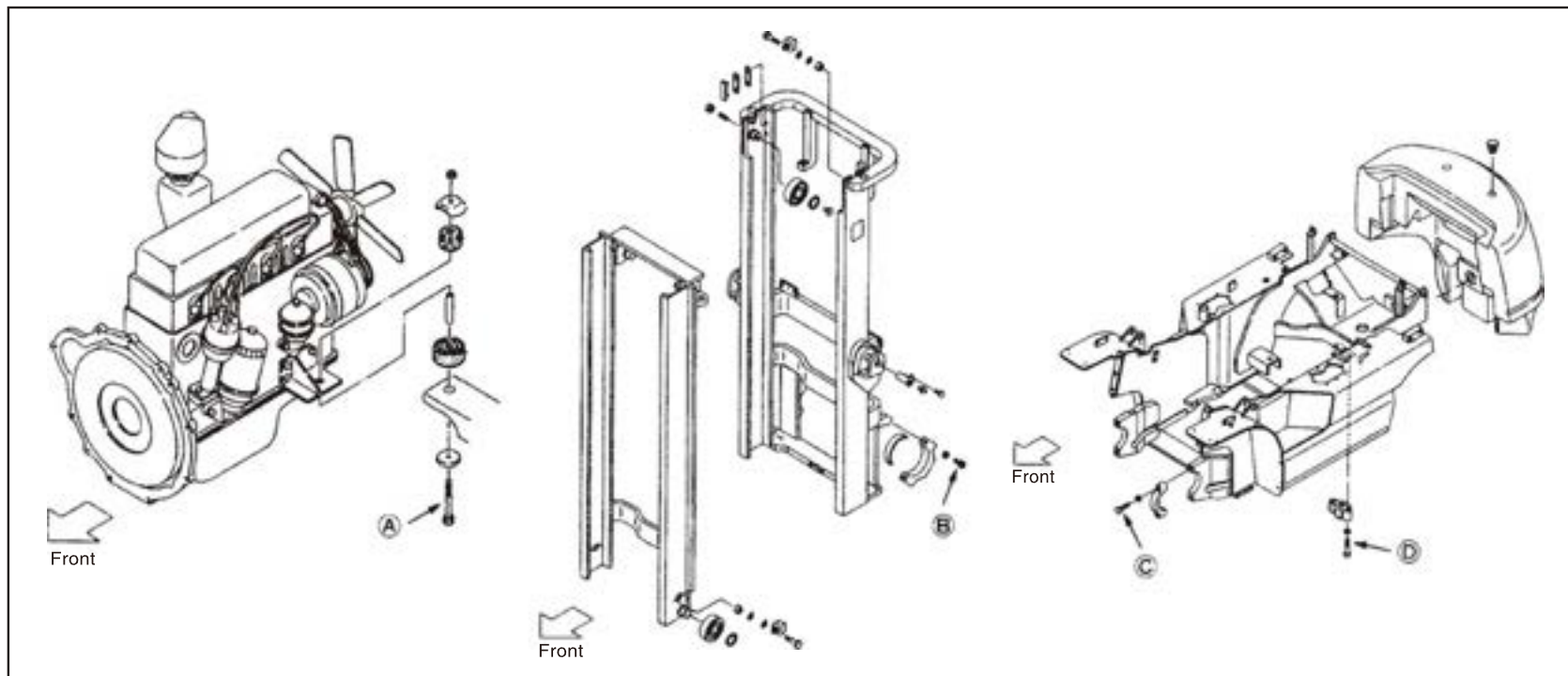

Ⓐ Engine mount bolt	
Torque	32 - 49 N-m (3.3 - 5 kg-m)

Ⓒ Front axle mount bolt	
Torque	75 - 111N-m (7.6 - 11.3kg-m)

Ⓑ Mast support cap bolt	
Torque	[2 to 3t] 148 - 223 N-m (15.1 - 22.7 kg-m)

Ⓓ Rear axle mount bolt	
Torque	153 - 230 N-m (15.6 - 23.4 kg-m)

SERVICE DATA

REFILL CAPACITY

Item	Truck model	Standard 2 - to 4-ton	Ambient temperature when engine is started
1	Hydraulic oil tank	32L / 8.45gal	32# HYDRAU LIC OIL
2	Brake reservoir tank	0.2L / 0.05gal	4902#
3	Transmission, differential (C type)	D 11L / 2.9gal	GEAR OIL
4	Reduction gear, differential (T type)	D 7.5L / 1.98gal	
5	Transmission, torque converter (T type)	3T / 6000lb 7L / 1.85gal	-25°C & above: GEAR OIL -40°C & above: GEAR OIL
6	Radiator	490BPG 10.7L / 2.82gal	COOLANT (50%)
7	Fuel tank	70L / 18.5gal	
8	Engine crankcase		C-1, S-3, X-3 SD/CC C-1 SAE10W-30 (-25°C ~35°C) CD X-3 SAE10W (-25°C ~35°C) CD S-3 SAE30(0°C)
9	Grease fittings	As required	LUBRICANTS

- Notes:
1. Use light oil for diesel engine trucks.
 2. For more information about lubricants to be used, contact your local dealer.

SERIAL NUMBERS OF MAJOR COMPONENTS

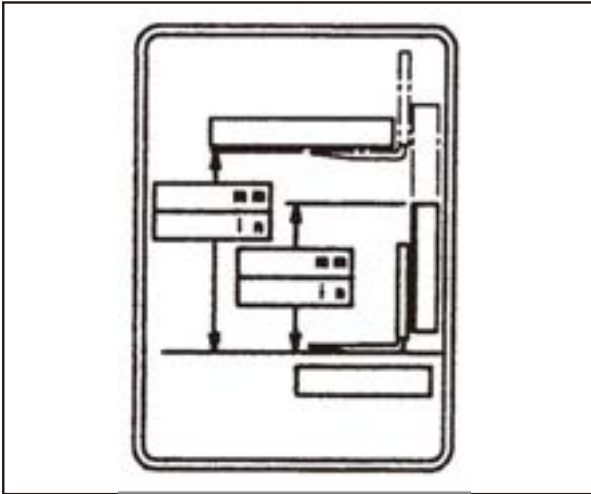

In addition to the truck serial number, the serial numbers (unit numbers) of the major components are imprinted on the truck or indicated on name plates. The above sketch shows the serial number plate of the mast. These decals should be replaced immediately if missing or defaced (damaged or illegible).

AFTER-THE-SALE SERVICE

GENUINE EKKO PARTS

However excellent a part is, it is inevitably deteriorates in performance with a longtime use. To ensure the best performance of the lift truck, use genuine parts which are used for new trucks.

When ordering spare parts, be sure to designate genuine parts.

AFTER-THE-SALE SERVICE

WRITE DOWN DATA OF YOUR TRUCK HERE:

TRUCK -----
MODEL -----
Truck Serial No -----
Service Weigh ----- kg (lbs)
Max. Load ----- mm (in.): ----- kg (lbs)

ENGINE
Manufacturer -----
Model -----
Engine Serial No -----

DATE OF PURCHASE-----
DEALER'S NAME ----- PHONE -----
DEALER'S ADDRESS -----