

EKKO[®]

MATERIAL HANDLING EQUIPMENT

MOVING AHEAD

SEMI-ELECTRIC STRADDLE STACKER EA15B

- 3300 lbs. Capacity
- 119.4" lift Height
- Narrow Aisles 7 ft.
- Adjustable Legs 45.7-59.1 in.
- Adjustable Forks 8.3-33.5 in.
- Batteries and Charger Included
- 3 Year Limited Warranty



EA15B

Superior quality, maneuverable, compact, and durable for all your material handling applications. Ideal for small aisles and areas.

WEIGHT CAPACITY: 3300 lbs. @ 24" load center

LIFT HEIGHT: 119.4" (9.95 ft.)

FORK LENGTH: 45.3"

ADJUSTABLE OUTRIGGERS: 45.7" TO 59.1"

ADJUSTABLE FORKS: 8.3" TO 33.5"

MAST HEIGHT: 84.5"

TURNING RADIUS: 53.2"

INTEGRAL BATTERY / CHARGER: 12V 120AH, deep cycle maintenance-free batteries with external direct connect 110A 110VAC plug-in automatic 24V/15A charger (both Included)

LIFTING SPEED: 5.35 ips empty; 3.6 ips loaded

LOWERING SPEED: 3.85 ips empty; 4.4 ips loaded

DRIVE WHEELS: 9" x 3" Nylon

LOAD WHEELS: (2) 4" x 3" Nylon per outrigger

HYDRAULICS LIFTING MOTOR: 24V 1500 Watt lifting Motor.

BRAKES: Foot Brake

OPERATOR CONTROLS: lifting, lowering, battery meter

CHASSIS AND MAST: Robotic Welding; Heavy duty steel chassis with I-beam mast for durability; Telescoping mast includes a protective steel guard.



Walkie Straddle Stacker

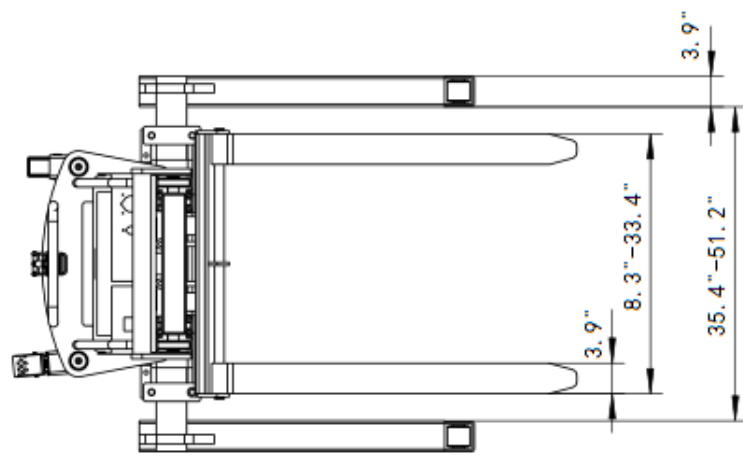
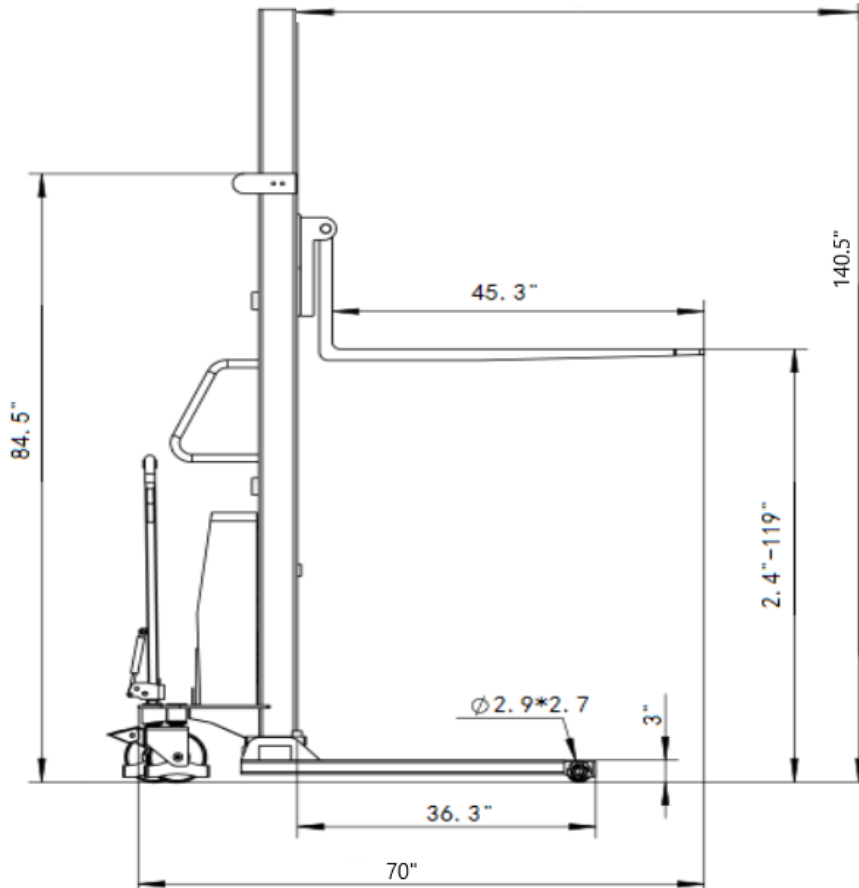

MODEL #	MAST	LIFT HEIGHT	SERVICE WEIGHT
EA15B	84.5"	119.4"	1200



1761 W. Holt Ave.
 Pomona, CA 91768 USA
 T: (877) 232-6517 F: (909) 222-6861

AUTHORIZED DEALERS ONLY
www.ekkolifts.com