

3 Wheel Lithium Forklift EK16A-189LI

- 3500 lbs. load capacity
- Lift height 189" (15.75')
- Side Shift
- Tilt
- Lowered Mast Height 81.3"
- Cushion Tire
- Battery 24V/200AH
- Charger Included
- AC Drive Assembly
- AC Hydraulic Power Steering



3 Wheel Lithium Forklift

EK16A-189LI



Model (Manufacturer's type designation)		EK16A-189LI
Power Type		
Load Capacity/Rated Load	Q(lb.)	3500
Load Centre Distance	C(in)	24
Lift height	h3(in)	189
Free lift height	h2(in)	31.5
Mast/fork carriage tilt forward/backward	α/β (°)	1.92/3.9
Lowered mast height	h1(in)	81.3
Overhead load guard(cab) height	h5(in)	77.6
Ground clearance, Centre of wheelbase	m1(in)	3.4
Length to face of forks	l2(in)	65
Overall width	b1(in)	42.1
Fork dimensions	s/e/l(in)	1.4x4.0x42.1
Fork Adjustment Range	in	7.9/26
Load distance, Centre of drive axle to fork	x(in)	7.2
Turning radius	Wa (in)	58.9
Extended mast height	h4(in)	192.1
Travel speed, laden	mph	4.2
Travel speed, unladen	mph	4.6
Lift speed, laden/unladen	in/s	4.71/10.2
Drop speed, laden/unladen	in/s	11.8/15.7
Max gradient performance, laden	%	6
Max gradient performance, unladen	%	10
Service brake		Electric Brake
Tire (front x N)		Φ305x145/2
Tire (rear x 1)		Φ250x120
Track width, front	in	35.8
Wheelbase	in	49.2
Axle loading, laden front	lb.	707.8
Axle loading, laden rear	lb.	1070
Axle loading, unladen front	lb.	180.8
Axle loading, unladen rear	lb.	282.2
Drive motor	kw	2.2
Lift motor	kw	3.3
Battery voltage, nominal capacity k5	V/Ah	24V/200 (Lithium)
Type of drive control		AC
Manufacturer of drive control+C16A13:C37A1:C37		ZAPI

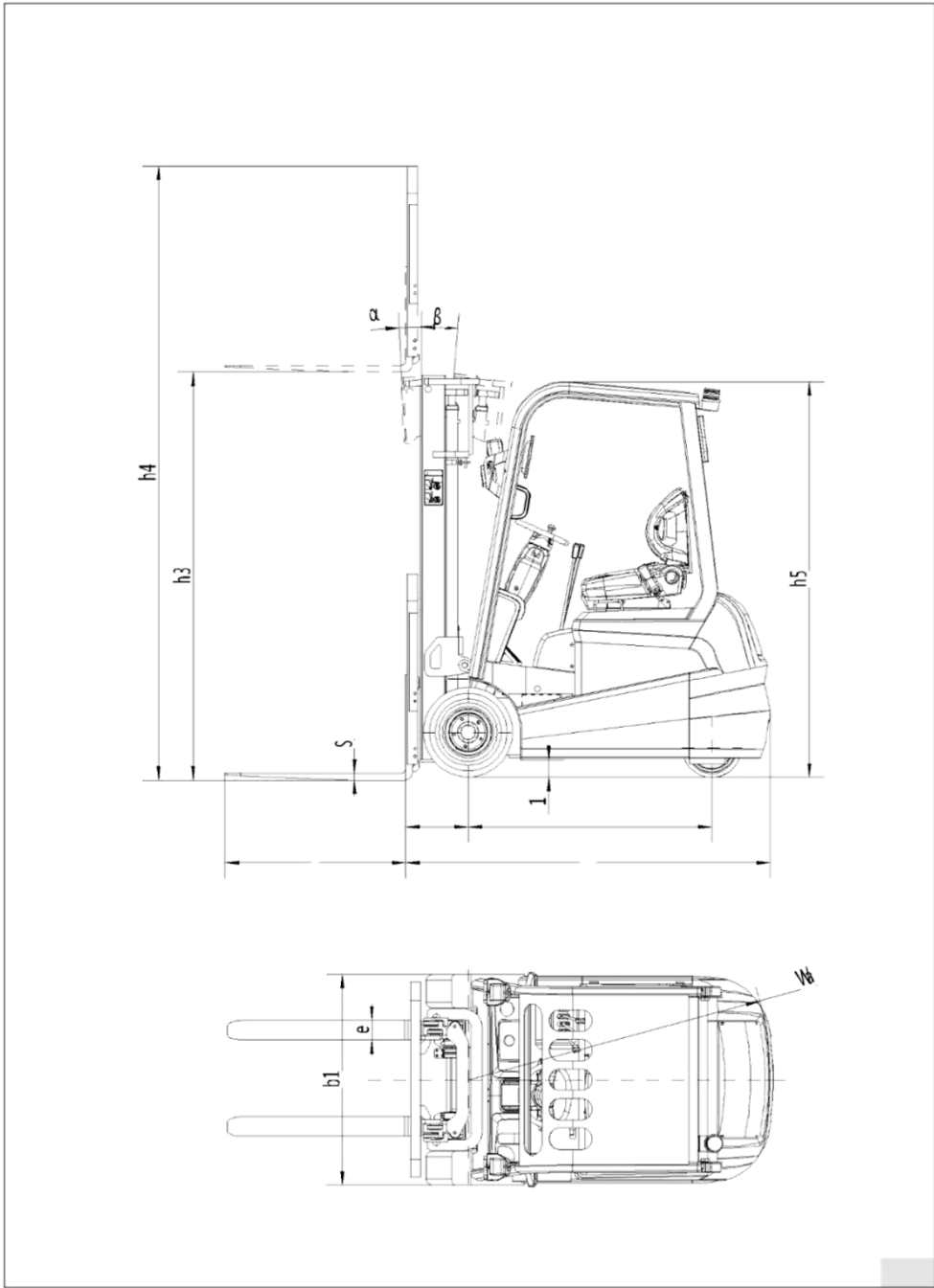

MODEL #	MAST	LIFT HEIGHT	MAX MAST HEIGHT	SERVICE WEIGHT
EK16A-189Li	81.3"	189"	192.1"	4650 Lbs.