

Operations & Maintenance Manual

Three Wheel Forklift

EK16A-177/EK16A-138/EK16A-189LI





Warning

Before using this equipment, first pay attention to the following matters:

- Please read this manual carefully and operate the vehicle safely.
- Do not operate this vehicle without training.
- Please comply with ISO3691 "Safety Specification for Motor Vehicles Industry".
- Please do not modify the repair or change the parameters to adjust the pressure, the loss of the car will be borne by you, and you will lose our warranty commitment.
- overload is strictly prohibited. The load weight and load center shall comply with the requirements of the parameter table in this manual.
- When the vehicle is used for stacking, the center of gravity of the goods must be within two cargo forks. Stacking loose goods is strictly prohibited.
- No human operation is allowed on the fork.
- The power supply should be turned off in time after the operation is completed.

Special warning: the company adheres to the strategy of innovation and sustainable development; Therefore, it is possible to improve the technology of the products. Therefore, we reserve the right to make changes and improvements to any product described in this specification without prior notice.

FORWARD

Our company's balanced electronic forklift is developed from both domestic and international designs, integrating advanced production capabilities with innovative features created by our R&D department. These forklifts are ideal for handling and stacking packaged goods in various environments, including stations, ports, and warehouses, and are widely used in the food and textile industries. With additional attachments, these forklifts can serve a variety of purposes.

Key features include a wide visibility lifting system, a fully hydraulic steering system, self-energizing brakes, an overhead guard with an open port, and high-quality motors and batteries. They are equipped with ZAPI control technology and a multifunctional panel, offering numerous advantages such as excellent performance, ease of operation, enhanced visibility for the operator, flexible steering, reliable brake, smooth and powerful operation, low noise levels, reduced environmental impact, and an aesthetically pleasing design.

This manual primarily provides specifications, technical data, operating procedures, maintenance guidelines, service instructions, and details on the construction and working principles of the forklift. It is essential for operators to read this manual thoroughly before operating the forklift to ensure optimal performance.

All personnel involved with the forklift must adhere strictly to the rules and notices outlined in this manual. This will help maintain the trucks in an optimal working state for an extended period and maximize their efficiency.

As attachments and components continue to evolve, the content of this manual will be updated accordingly. We apologize for any lack of additional information.

Table of Contents

Warning.....	1
Forward.....	2
Driving, Operation, and Daily Maintenance of the Forklift.....	5
1. Transportation of the forklift.....	5
2. Forklift storage.....	5
3. Preparation before work.....	5
4. Operation instructions.....	5
5. Battery charging.....	7
6. Lubrication system.....	7
Construction, Principle, Adjustment and Maintenance of Forklift.....	10
1. Transmission System.....	10
2. Drive motor shaft.....	10
3. Input shaft.....	10
4. Output shaft.....	10
Turn to the system.....	12
1. Overview.....	12
2. Cycloid full hydraulic steering gear.....	12
3. Hydraulic motor assembly.....	14
4. Steering system reinstallation after inspection.....	15
Electric System.....	16
1. General description.....	16
2. Electric controller assembly.....	17
3. Instrument.....	18
4. Wiring Diagram.....	18
5. Circuitry.....	18
Fault Diagnosis.....	21
1. ZAPI Controller fault diagnosis.....	21
2. Display LCD instructions for fault diagnosis.....	21
Hydraulic system.....	24
1. Overview.....	24
2. Pump.....	25
3. Control Valve.....	25
4. Lifting cylinder.....	30
5. Flow regulator valve.....	33
6. Tilt cylinder.....	34
7. Hydraulic oil tank.....	35
8. Hydraulic oil pipeline.....	35

9. Maintenance of lift pump.....	36
10. Troubleshooting.....	40
Lifting System.....	42
1. General Description.....	42
2. Inner and outer masts.....	42
3. Lift bracket.....	43
4. Layout of rollers.....	44
5. Adjust lift cylinder.....	45
6. Adjust lift bracket height.....	45
7. Replacing rollers of the lift bracket.....	46
8. Replacing rollers of masts.....	46
Battery forklift maintenance.....	47

Driving, Operation, and Daily Maintenance of the Forklift

The driver and administrator of the forklift must prioritize safety and adhere to standard operating procedures as outlined in the Operator's Manual and Maintenance Guide.

1. Transportation of the Forklift

When transporting the forklift in a container or on a vehicle, pay attention to the following:

- a. Engage the Brake: Ensure the brake lever is locked.
- b. Secure the Forklift: Use steel cables to secure the front and rear brackets. Cushion the front and rear tires.
- c. Lifting Procedure: Follow the designated signal for lifting loads.

2. Forklift Storage

To store the forklift properly:

- a. Lower the Bracket: Position the bracket at its lowest setting.
- b. Power Down: Close the electric lock, set all control levers to neutral, and disconnect the power socket.
- c. Engage Hand Brake: Pull the hand brake lever tightly.
- d. Cushion Tires: Ensure the front and rear tires are cushioned.
- e. Long-Term Storage: If the forklift is not used for an extended period, lift the tires off the ground and charge the battery monthly.

3. Preparation Before Work

Before operating the forklift, check the following:

- a. Indicator Lights: Ensure all indicators are functioning.
- b. Tire Pressure: Check the air pressure of the tires.
- c. Controls and Brakes: Inspect all handles and the brake pedal for proper function and flexibility.
- d. Battery Voltage: Confirm the battery voltage is within the operating range and check the electrolyte levels.
- e. Electrical Connections: Verify that all connections and sockets in the electrical system are secure.
- f. Tightness of Components: Ensure all main components are tightened properly.
- g. Lights and Signals: Check that headlights and signals are operational.
- h. Parking Brake: Release the parking brake.
- i. Operational Test: Test lifting, tilting, steering, and braking mechanisms.
- j. Pollution Level: Ensure the pollution level is below 12.

4. Operation Instructions

- a. Qualified Operator: Only trained and licensed individuals may operate the forklift.
- b. Safety Gear: Operators must wear appropriate safety shoes, hats, clothing, and gloves.
- c. Monitor Conditions: Pay attention to the forklift's mechanism, hydraulic system, and electrical system during operation.
- d. Starting Procedure: Connect the power, turn on the key switch, select the directional switch, steer the wheel to check for normal rotation, and slowly depress the accelerator to maintain a safe starting speed.
- e. Battery Monitoring: If the voltage drops below 41V during operation, stop immediately and charge or replace the battery.
- f. Load Limits: Do not exceed the forklift's load capacity. Ensure the load is evenly distributed on the forks, fully inserted below the goods to prevent overload or tilting.
- g. Wet or Slippery Conditions: Reduce speed when operating on wet or slippery surfaces.
- h. Caution on Quays and Ramps: Drive slowly and carefully on docks or interim boards.
- i. Safety Around Forklift: No personnel should stand under the forklift, and lifting with people onboard is prohibited.
- j. Controlled Lifting Speed: Avoid rapid acceleration when lifting or lowering the forklift.
- k. Stay Seated: Do not operate the vehicle or equipment while standing outside the driver's seat.
- l. Neutral Gear: Return controls to neutral promptly when the bracket is fully tilted or lifted.
- m. Load Position: Keep the load as low as possible, tilting the bracket backward while driving. Do not steer or operate the forklift while lifting.
- n. Watch for Hazards: Be aware of pedestrians, obstacles, and overhead clearances.
- o. Driving on Slopes: Exercise caution on inclines. Ascend a slope moving forward and descend in reverse. Avoid steering or loading on slopes.
- p. Safety Measures: Be vigilant when lifting loads over three meters; take protective actions as necessary.
- q. Secure Loads: Do not transport unsecured or loose items and handle large items with extra care.
- r. Avoid Sudden Stops: Refrain from abrupt braking while carrying loads.
- s. Parking Procedure: When leaving the forklift, ensure the forks are resting on the ground, set controls to neutral, and disconnect the power. Engage the parking brake on slopes and use wheel blocks if parking for an extended period.
- t. Pressure Settings: Do not adjust the relief valve or steering unit pressure settings during operation to avoid damaging the hydraulic system.
- u. Tire Pressure: Follow the specified tire pressure guidelines for inflation.

- v. **Using Attachments:** Operate the forklift with attachments as if it were carrying a load.

5. Battery Charging

- a. **Follow Instructions:** Adhere strictly to the battery manufacturer's instructions when charging for the first time.
- b. **Regular Checks:** Continuously monitor the electrolyte ratio, liquid level, and temperature during the charging process.
- c. **Timely Charging:** Recharge the battery as soon as possible after using the forklift. Do not exceed a charging time of 24 hours. Avoid undercharging and overcharging to prevent damage to the battery.

Refer to the battery's instruction manual for proper charging and maintenance procedures.

6. Lubrication System

Lubrication System Diagram

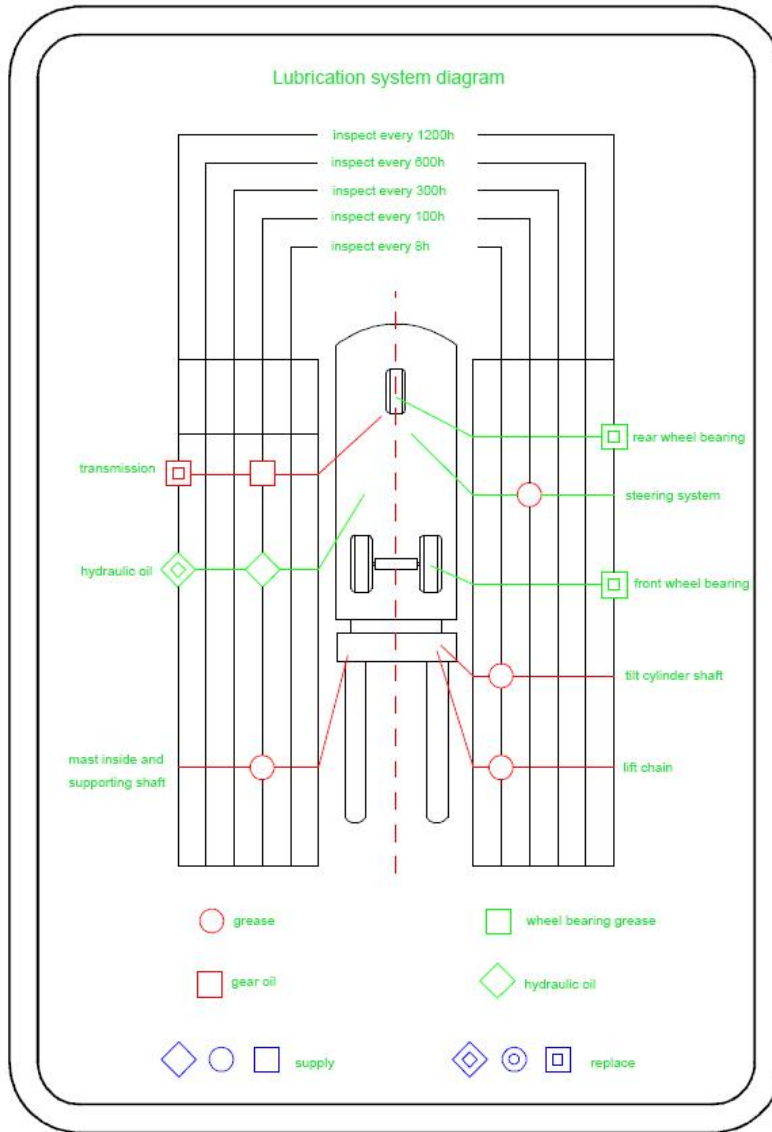

Main Technical Parameter of the Forklift

External View of the Forklift

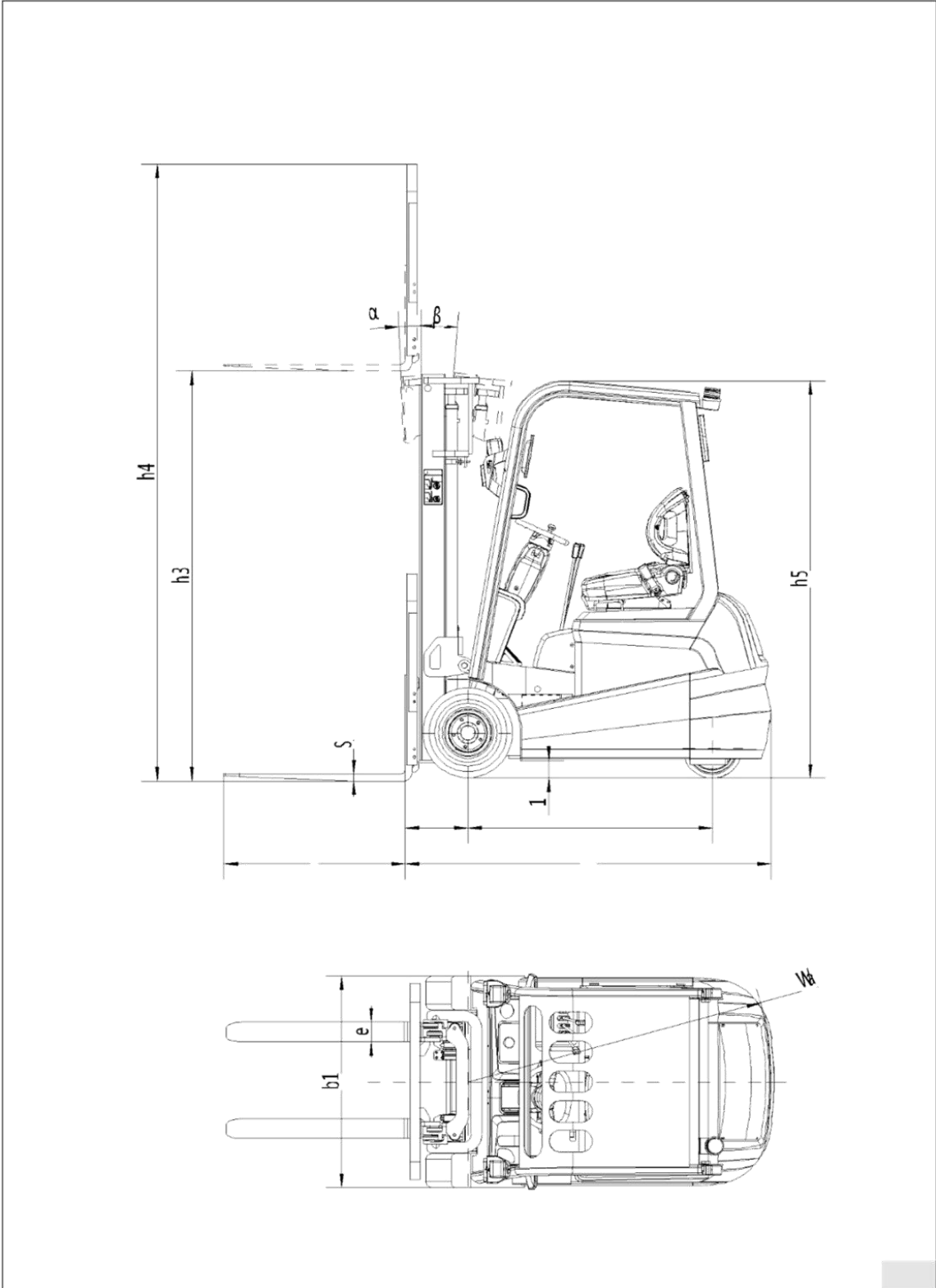

Technical Parameter

2	型号	Manufacturer's type designation	CPDS12	CPDS16	CPDS18
3	动力形式	Drive		Electric	
4	额定起重量	Load capacity/rated load	1200	1600	1800
5	载荷中心距	Load centre distance		500	
6	起升高度	Lift height		3000	
7	自由起升高度	Free lift	135	135	135
8	门架倾角(前/后)	Mast/fork carriage tilt forward/backward	4/5		3/5
9	门架不起升高度	Lowered mast height	2012		2025
10	护顶架高度	Overhead load guard(cab) height	1966		2010
11	离地间隙	Ground clearance,centre of wheelbase	86		90
12	外形尺寸总长(不含货叉)	Length to face of forks	1640		1861
13	宽度	Overall width	1070		1070
14	货叉规格	Fork dimensions	35x100x920		35x100x920
15	货叉调节范围		200/660		200/970
16	前悬距	Load distance,centre of drive axle to fork	170		324
17	最小转弯半径	Turning radius	1495		1537
18	作业时最大高度	Extended mast height	4047		4047
19	直角堆垛通道宽度(1000x1200 横向)		3010		3186
20	直角堆垛通道宽度(800x1200 纵向)		3125		3308
21	运行速度(满载)	Travel speed,laden	6.4		7.5
22	运行速度(空载)	Travel speed,unladen	7.2		8.5
23	提升速度(满载/空载)	Lift speed,laden/unladen	120/260		160/260
24	下降速度(空载)	Drop speed,laden/unladen	300/400		350/428
25	最大爬坡度(满载)	Max gradient performance,laden	6		8
26	最大爬坡度(空载)	Max gradient performance,unladen	10		12
27	制动系统	Service brake		电制动	
28	轮胎(前×N)	Tyre size,front		Φ305x145/2	18x7-8/2
29	轮胎(后×1)	Tyre size,rear		Φ250x120	Φ300x120
30	前轮距	Track width,front	910		891
31	后轮距	Track width,rear	0		0
32	轴距	Wheelbase	1250		1240
33	自重(包括电瓶)	Service weight incl.battery	2075	2100	2736
34	前桥负荷(满载)	Axle loading,laden front	2665	3210	4036
35	后桥负荷(满载)	Axle loading,laden rear	610	490	500
36	前桥负荷(空载)	Axle loading,unladen front	815	820	1116
37	后桥负荷(空载)	Axle loading,unladen rear	1260	1280	1620
38	行走电机	Drive motor	2.2		3
39	起升电机	Lift motor	3.3		4.5
40	标配蓄电池	Battery voltage,nominal capacity k5	24V/320	24V/320	24V/400
41	控制器类型	Type of drive control	交流AC		交流AC
42	控制器制造商	Manufacturer of drive control	ZAPI		
43	工作压力	Operating pressure for attachments			16

Construction, Principle, Adjustment and Maintenance of Forklift

1. Transmission System

Model	EK16A	
Ratio	21.378	15.8487
Wheel Dia. x Width	Φ250×120	Φ300x120
Oil Volume	2.2L	3L
Gear Oil Type	85W/90	

The main fulcrum of the three-point counterbalanced forklift is the mechanical gearbox (see Figure 1-1). The drive wheel is secured to the flange of the drive shaft using hub bolts and a hub nut. Power is transmitted to the output shaft via the mechanical gearbox, which in turn drives the wheel to rotate.

The mechanical transmission consists mainly of the drive motor shaft, input shaft, output shaft, and associated gears. Each shaft may feature one or more gears with varying numbers of teeth. Power from the motor is transmitted to the input shaft via the input gear on the motor shaft. The input shaft then transmits power to the output shaft through a pair of helical bevel gears, ultimately driving the wheel rotation.

2. Drive Motor Shaft

The drive motor shaft features a roller with an "O" ring. The pinion is fixed onto the output shaft of the drive motor using a key and secured with a nut.

3. Input Shaft

The input shaft is mounted within the gearbox casing on two tapered roller bearings. It meshes with the helical bevel gear on the output shaft. A large helical gear is mounted on the input shaft via a key and secured with a lock nut. This gear meshes with the pinion on the drive motor shaft. The gap between the input shaft and the helical bevel gear is adjusted using two sets of shims.

4. Output Shaft

The output shaft is supported in the transmission case by two tapered roller bearings. The helical bevel gear is secured to the output shaft with a lock nut. The large wheel is mounted on the flange of the drive shaft using a hub nut. Clearance on the output shaft is also adjusted with shims.

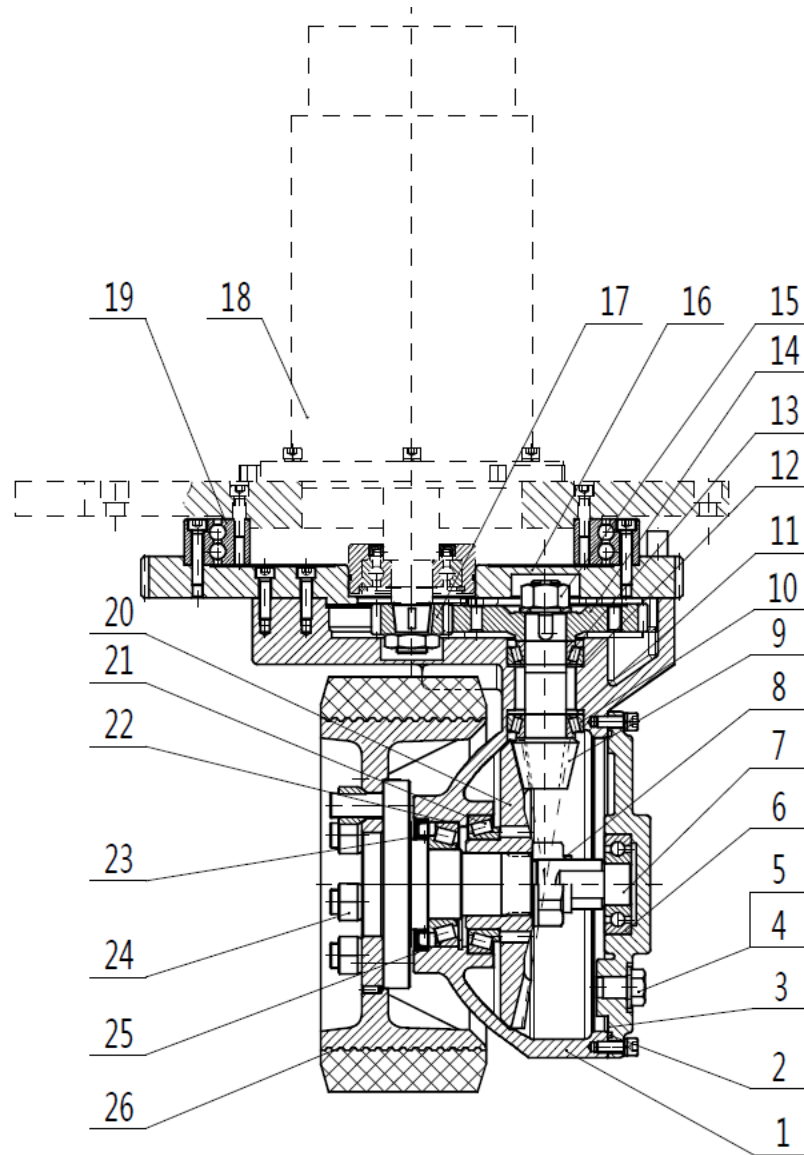

Figure 1-1

1. Cabinet	2. O-ring	3. Cover
4. Combination pad	5. Oil drain plug	6. Ball bearings
7. Output shaft assembly	8. Nut	9. Input shaft
10. Taper roller bearings	11. Adjusting the spacer	12. Adjust the spacer
13. Tapered roller bearings	14. Large helical gear	15. Nut
16. Turntable gear	17. Pinion	18. Drive motor
19. Large bearing	20. Spiral bevel gear	21. Tapered Roller Bearings
22. Adjusting Washer	23. Skeletal Oil Seal	24. Hub nut
25. Tapered roller bearings	26. Drive wheel	

Turn to the system

1. Overview

The steering system primarily consists of the steering wheel, steering shaft, steering gear, hydraulic motor, and connecting components. The steering shaft is connected to the steering gear via a universal joint, while the connecting shaft links the steering wheel to the system through another universal joint. The steering column can be adjusted to a comfortable position (as illustrated in Figure 2-1).

Both the hydraulic motor and steering gear are mounted on the drive mounting plate located at the rear of the frame. The hydraulic motor powers the steering gear, allowing for the deflection of the steering wheel and enabling smooth steering control.

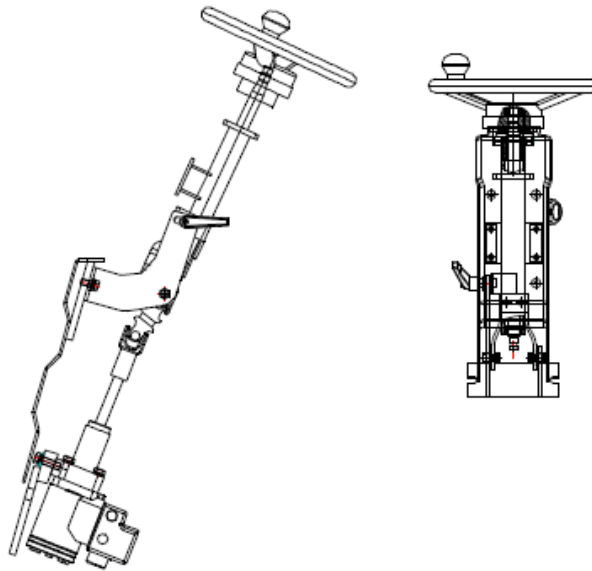

2. Cycloid Full Hydraulic Steering Gear

The fully hydraulic steering system (see Figure 2-2) measures the angle of the steering wheel to determine the amount of hydraulic oil to be delivered from the steering pump to the steering cylinder via the pipeline. If the pump is unable to supply oil, the steering can still be operated manually.

The steering gear consists of a standard steering gear and a combination valve. The upper cover of the combination valve features a hole that serves as the system safety valve. Additionally, a two-way overload valve is incorporated within the valve body to protect against high pressure in the hydraulic system caused by external impacts to the wheels while the forklift is in operation. This prevents potential damage to components.

Both the safety valve and the two-way overload valve are factory-adjusted and should not be altered by users.

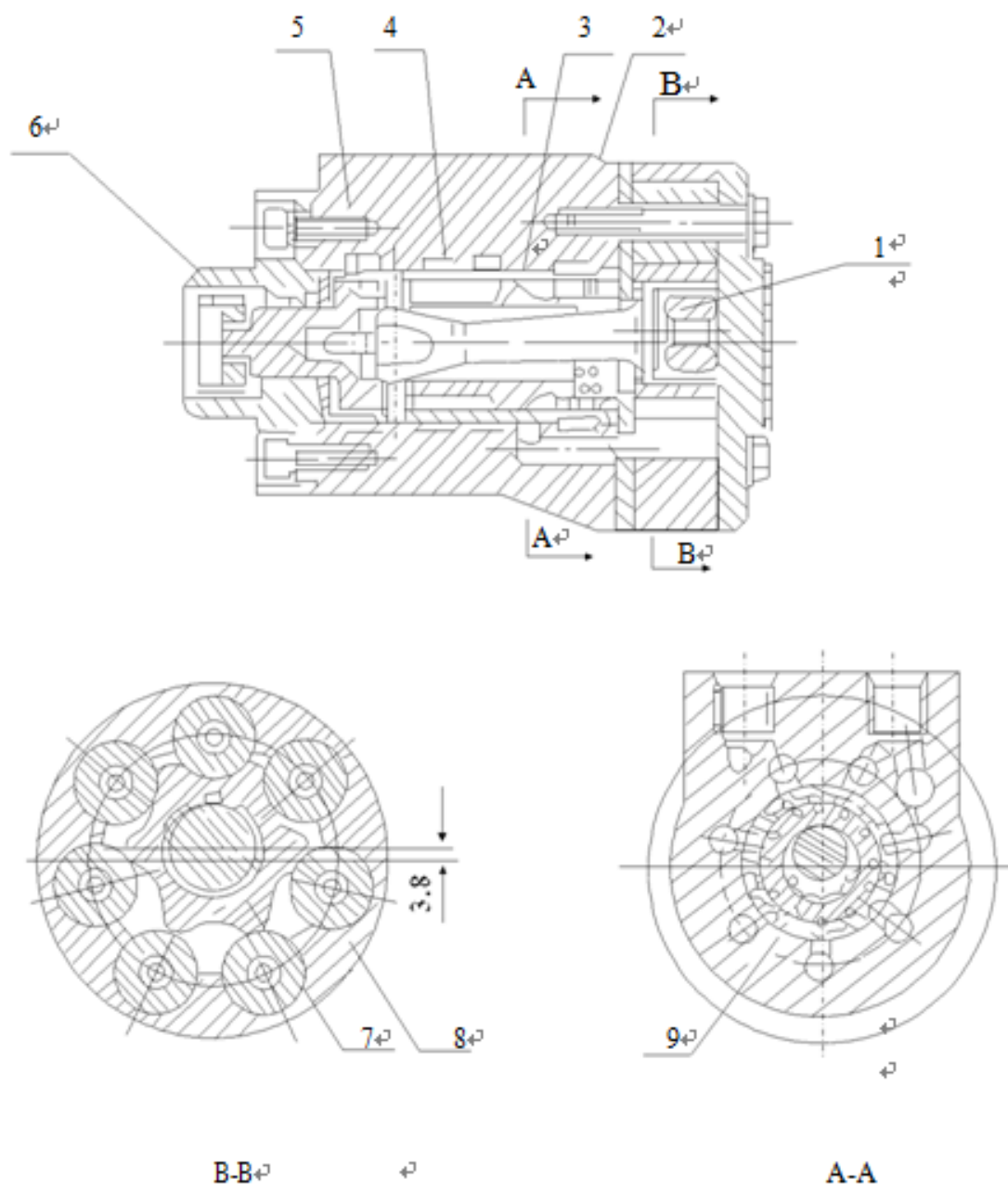

Figure 2-2

1. Limit column	2. Body	3. Spool
4. Linkage axis	5. Spring	6. Connection block
7. Rotor	8. Stator	9. Valve sleeve

3. Hydraulic Motor Assembly

The pinion is secured to the mounting seat using two ball bearings and is connected to the hydraulic motor via a key. Power from the hydraulic motor is transmitted through the pinion gear to the gearwheel, which is splined to the gear shaft. This power is then transferred from the gear shaft to the transmission turntable gear, enabling the steering wheel to rotate left and right.

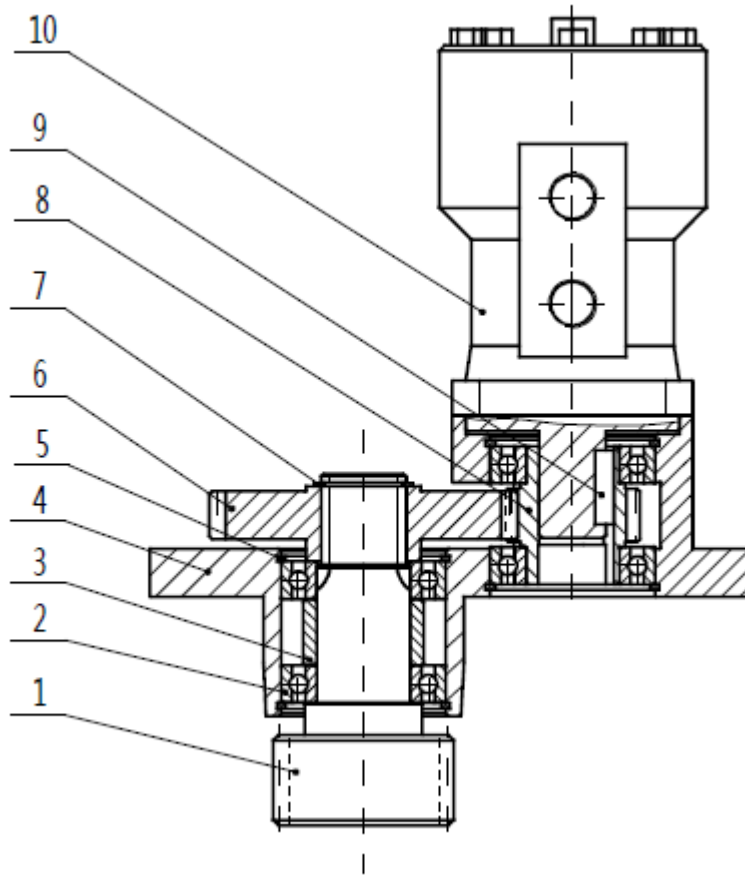

Figure 2-3

1. Gear shaft	2. Ball bearings	3. Spacer	4. Mounting seat
5. Retaining ring	6. Gear	7. Retaining ring	8. Pinion
9. Key	10. Hydraulic motor		

4. Steering System Reinstallation After Inspection

- a. **Smooth Operation:** Turn the steering handwheel to the right and left to ensure that the steering power is smooth.
- b. **Hydraulic Pipeline Check:** Inspect the connections of the hydraulic pipeline for correctness while turning the steering handwheel right and left.
- c. **Air Removal:** Lift the rear wheels off the ground and slowly turn the steering wheel right and left several times to exhaust air from the hydraulic pipeline and steering cylinder.

5. Steering System Troubleshooting

Problem	Analysis of Trouble	Remedies
Failure to Turn	Pump damaged or malfunctioning	Replace the pump
	Hose or joint damaged or pipeline blocked	Clean or replace hoses/joints
	Air in steering oil circuit	Bleed air from the system
Difficult to Turn	Spring component damaged or insufficient elasticity	Replace the spring component
	Pressure of the relief valve too low	Adjust the relief valve
	Oil leakage in the steering cylinder	Inspect the piston seal
Truck Snaking or Oscillation	Excessive flow rate in steering unit	Adjust flow to the steering unit
Excessive Noise	Low oil level in the oil tank	Refill oil
	Suction pipeline or oil filter blocked	Clean or replace filter
Oil Leakage	Damaged seals of guide sleeve, pipeline, or joints	Replace damaged seals/joints

Electric System

1. General Description

The electric system includes the battery, drive motor, lift motor, steering motor, speed control, control switches, integrated radiator, and lighting components. The circuit diagrams of the electric system are provided below.

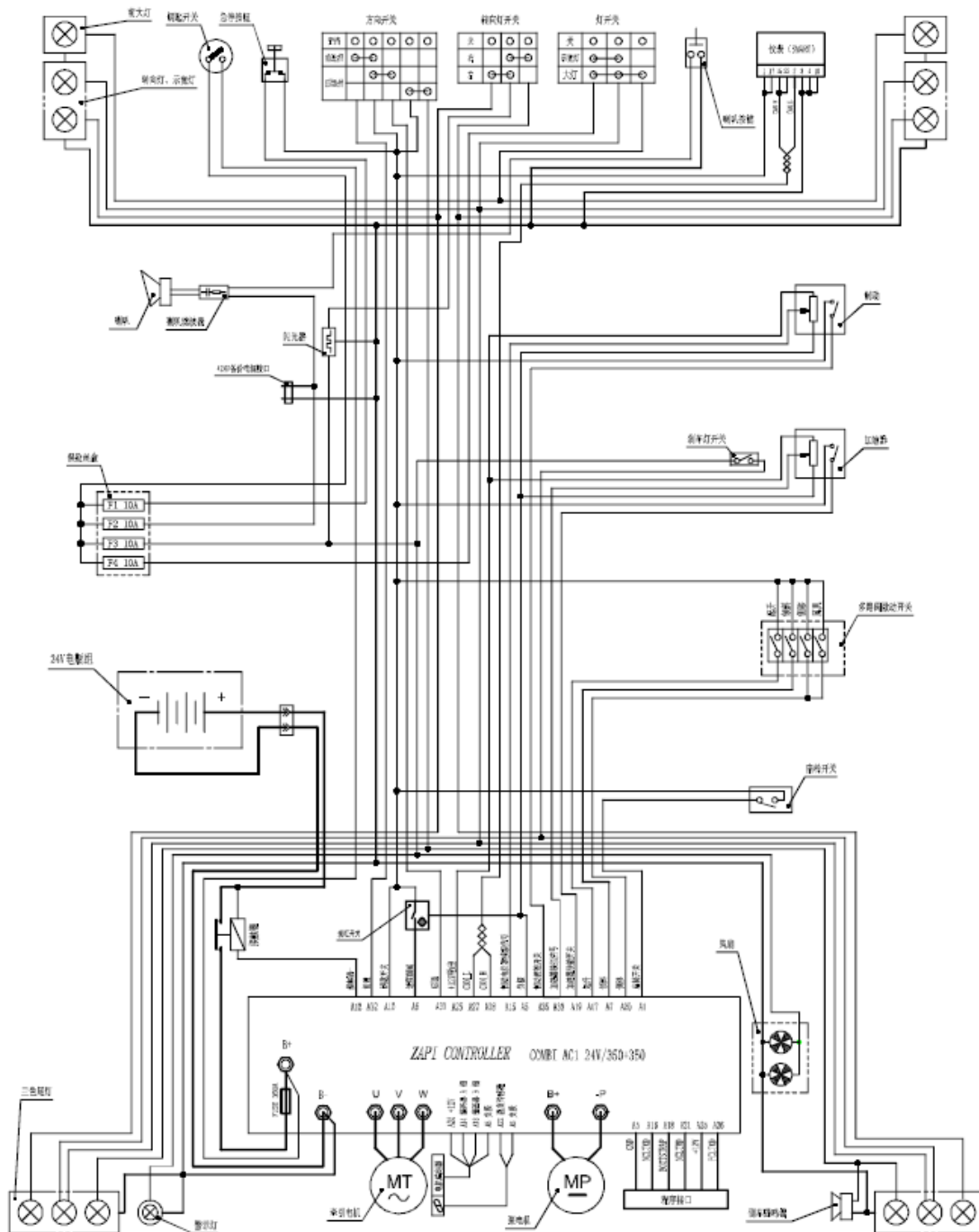

2. Electric Controller Assembly

The three-wheel full AC controller, manufactured by ZAPI in Italy, is designed for high reliability. This controller offers several advantages, including enhanced safety, flexibility, cost-effectiveness, and robust protection standards.

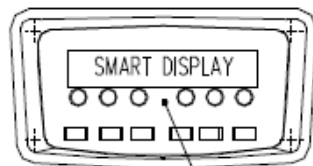
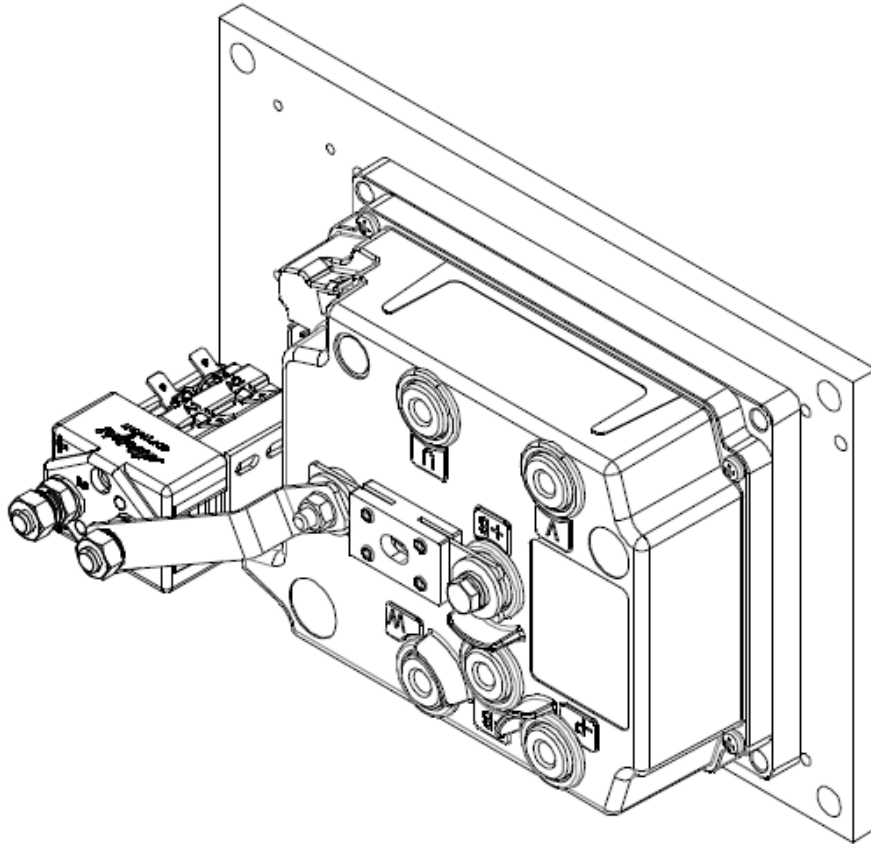

SMART instrument

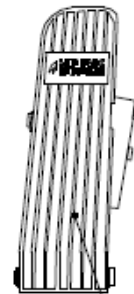

accelerator

3. Instrument

The integrated instrument, utilizing microcomputer technology, provides real-time data display for enhanced safety and comfort for the operator. It features a low voltage warning system to protect both the battery and the vehicle.

(1) Figure:

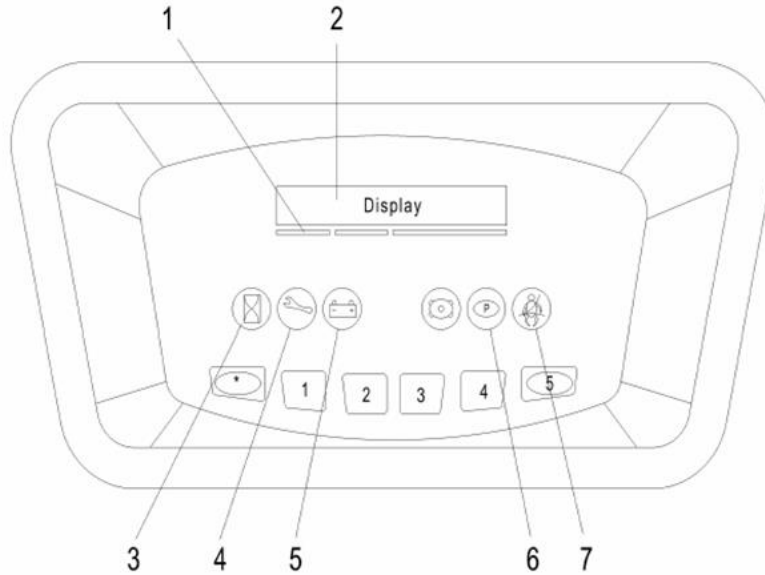

1. Battery discharge display	2. Alphanumeric display	3. Time
4. Repair the alarm	5. Battery alarm	6. Handbrake
7. Safety sea		

4. Wiring Diagram

Figure 3-4 Body Harness

Figure 3-5 Front Harness

Figure 3-6 Rear Harness

5. Circuitry

- a. 4-4 Forklift body part circuitry.
- b. 4-5 Headlight circuitry.
- c. 4-6 Taillight circuitry

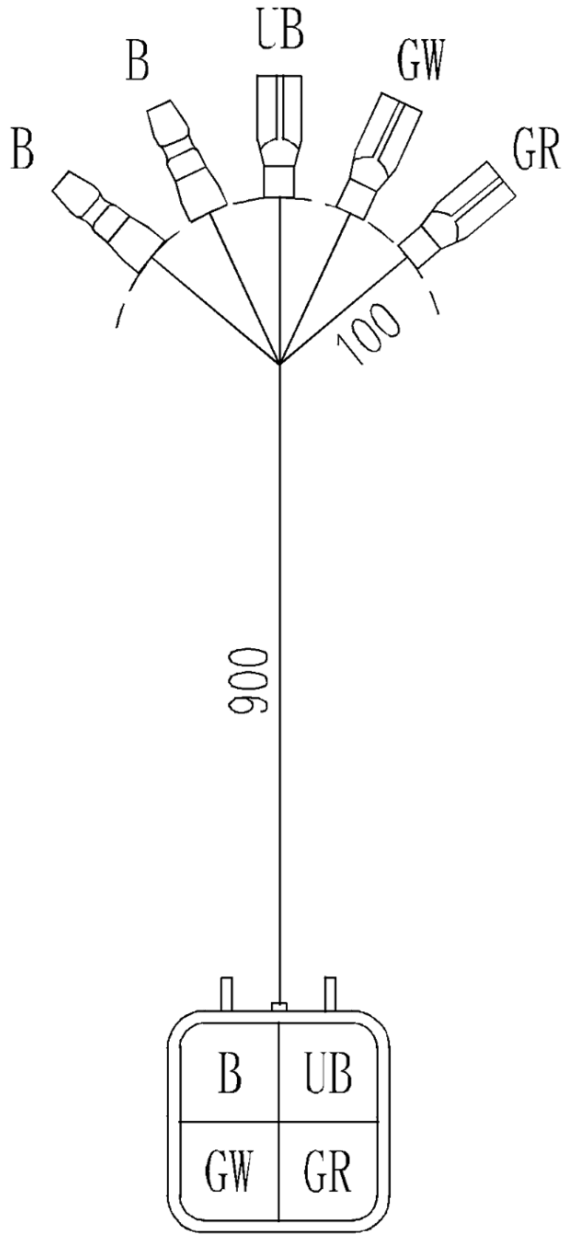

DJ7041Y-2.3-10

端子	型号
	DJ211-4B
	DJ221-4B

标志	线截面	线色
UB	0.85	蓝黑
GW	0.85	绿白
GR	0.85	绿红
B	0.85	黑

Fault Diagnosis

1. ZAPI Controller Fault Diagnosis

In the event of a forklift control system failure, the fault code will be displayed on the instrumentation. Repair personnel can use this information for fault detection. Refer to the attached "Fault Diagnosis Chart Instructions" in the "Fault Code" chapter of the manual for diagnosis and maintenance procedures.

2. Display LCD Instructions for Fault Diagnosis

When there is an electronic control failure in the vehicle, the fault indicator light will activate, and a fault code will be displayed. The corresponding fault codes and their diagnoses are listed in the table below.

Code	Description
249 CHECK UP NEEDED	Maintenance time is due. After servicing, set the parameter CHECK UP DONE to ON and restart.
250 THERMIC SENS.KO	Temperature sensor in the controller is damaged.
251 WRONG SET BAT	The voltage at the key switch does not match the set voltage level by more than 20%.
252 VACC NOT OK 2	Accelerator/lift potentiometer is pressed, causing the signal to exceed the minimum calibration value.
253 SLIP PROFILE	Incorrect parameter settings in the hardware menu.
254 AUX DRIV.SHRT	Auxiliary output port shorted to -BATT or another circuit, resulting in reduced voltage and inability to drive the coil. After replacing the assembly, ensure synchronization between components. Keep the key switch closed and wait about 2 minutes for the fault to clear.
234 BRAKE/QI RUN OUT	The output range of the brake potentiometer exceeds the calibration limits.
235 HANDBRAKE	Handbrake switch is not in the release position during operation.
236 CURRENT GAIN	Current gain parameter is not calibrated.
237 ANALOG INPUT	Analog-to-digital module is not functioning.
238 WRONG 0 VOLTAGE	Abnormal feedback value from the motor. Check the internal wiring, three-phase connections, and insulation between the terminal block and motor casing.
239 SAFETY OUTPUT	A19 port is shorted to -BATT or other lines, causing voltage to drop.
240 HARDWARE FAULT	The drive circuit for the main contactor/auxiliary output coil is damaged.
241 FLASH CHECKSUM	Software programming verification has failed.
242 ENCODER LOCKED	No feedback value from the encoder.
243 SENS MOT TEMP KO	Motor temperature sensor is damaged or disconnected.

Code	Description
244 SOFTWARE ERROR	Excessive interference on the CAN bus.
245 WRONG RAM MEMORY	RAM storage error.
246 AUX DRIV.OPEN	Coil on the auxiliary output circuit is not connected.
247 DATA ACQUISITION	Data acquisition is in progress; the fault will clear automatically once data retrieval is complete.
248 NO CAN MSG	Required information for the controller is missing.
223 WATCHDOG#1	WATCHDOG check has failed. If rebooting does not resolve the issue, there may be an internal circuit fault in the controller.
224 AUX COIL SHORT	Excessive current on A18 port.
226 VACC OUT RANGE	Output range of accelerator/lift potentiometer exceeds calibration limits.
227 WATCHDOG#2	WATCHDOG check has failed. If rebooting does not resolve the issue, there may be an internal circuit fault in the controller. This fault occurs after A6 port is disconnected with no operation for 30 seconds. If A6 port is closed or any other operation occurs, the fault will clear.
229 SAFETY INPUT	Safety line input is disconnected; not connected to -BATT or the pump control A19 port.
230 MC COIL SHORT	Main contactor coil is overloaded, shorted, or has too low resistance.
231 COIL SHORT HW KO	Circuit damage detected for the coils connected to A16 and A18 ports; "COIL SHORT HW 8X" indicates damage at A16 port; "COIL SHORT HW 0X" indicates damage at A18 port.
232 KEY OFF SHORT	Low voltage detected at the key switch terminal and the positive terminal of the controller when turning off.
233 POWER MOS SHORT	Power MOSFET is damaged.
31 VMN HIGH	Motor voltage is higher than expected.
37 CONTACTOR CLOSED	Contactor is stuck closed.
38 CONTACTOR OPEN	Contactor is not engaging.
53 STBY I HIGH	Static current is high.
60 CAPACITOR CHARGE	Capacitor pre-charge failure.
62 TH.PROTECTION	Controller temperature is too high.

Code	Description
65 MOTOR TEMPERATURE	Motor temperature is too high.
66 BATTERY LOW	Battery charge is low.
74 DRIVER SHORTED	Contactors coil is partially shorted.
75 CONTACTOR DRIVER	Contactors drive circuit fault.
78 VACC NOT OK	Accelerator/lift potentiometer is pressed, causing the signal to exceed the minimum calibration value.
79 INCORRECT START	Incorrect start sequence.
80 FORW+BACK	Simultaneous forward and reverse signals detected.
82 ENCODER ERROR	Error in encoder signal.
220 PROG VACC NOT OK	Minimum, middle, and maximum values of the accelerator/lift potentiometer do not match the calibration values.
221 SEAT MISMATCH	Seat switch for traction and pump control is not connected, causing inconsistent signals between the two controllers.
222 WAITING FOR NODE	Waiting for node response.

Code	Fault Name	Description
0	NONE	No fault
13	EEPROM KO	EEPROM failure
17	LOGIC FAILURE #3	Fault in overcurrent protection circuit part
18	LOGIC FAILURE #2	Fault in motor phase voltage feedback circuit
19	LOGIC FAILURE #1	Undervoltage or overvoltage fault
30	VMN LOW	Motor voltage is below expected level

Code	Fault Name	Description
243	PUMP INC	Warning: Pump start sequence is incorrect.
244	PUMP NOT OK	Warning: Pump accelerator voltage is 1V greater than the programmed minimum value of 0.50.

Hydraulic System

1. Overview

The hydraulic system includes the lift pump, steering pump, control valve, lift cylinder, tilt cylinder, and hydraulic lines.

The oil pump, which is directly connected to the motor, supplies hydraulic oil. The control valve distributes this oil to each pump.

For 2-3.5-ton forklifts, the oil tank is positioned at the rear, near the battery.

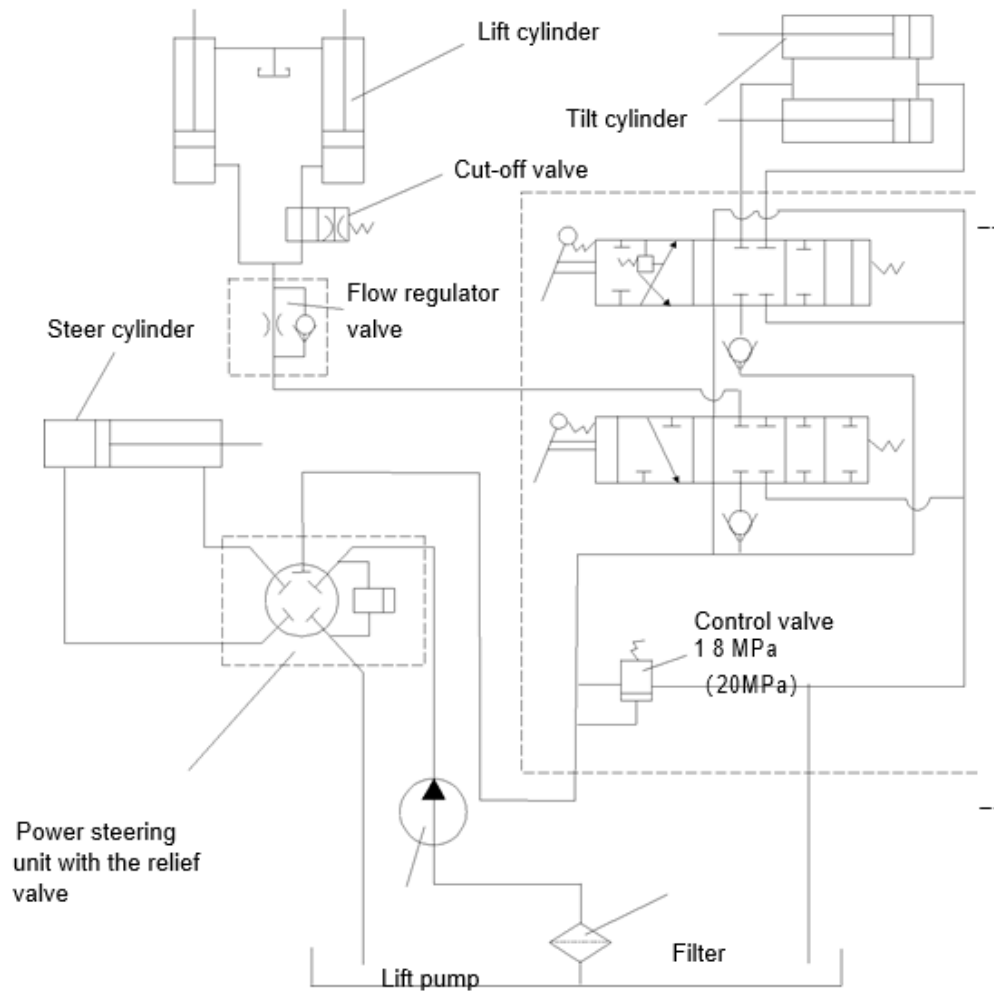

Fig.5-1 Hydraulic system

2. Pump

The electric forklift truck is equipped with gear pumps.

For the 2-3.5-ton forklift, the DSG05A18F9H1-R204C gear pump serves as the lift pump.

The lift pump is powered by the lift motor.

3. Control Valve

The control valve is a two-spool type and includes a four-valve housing with two spools. The relief valve features a four-valve housing secured with three bolts and nuts. The tilt spool valve incorporates a tilt lock valve.

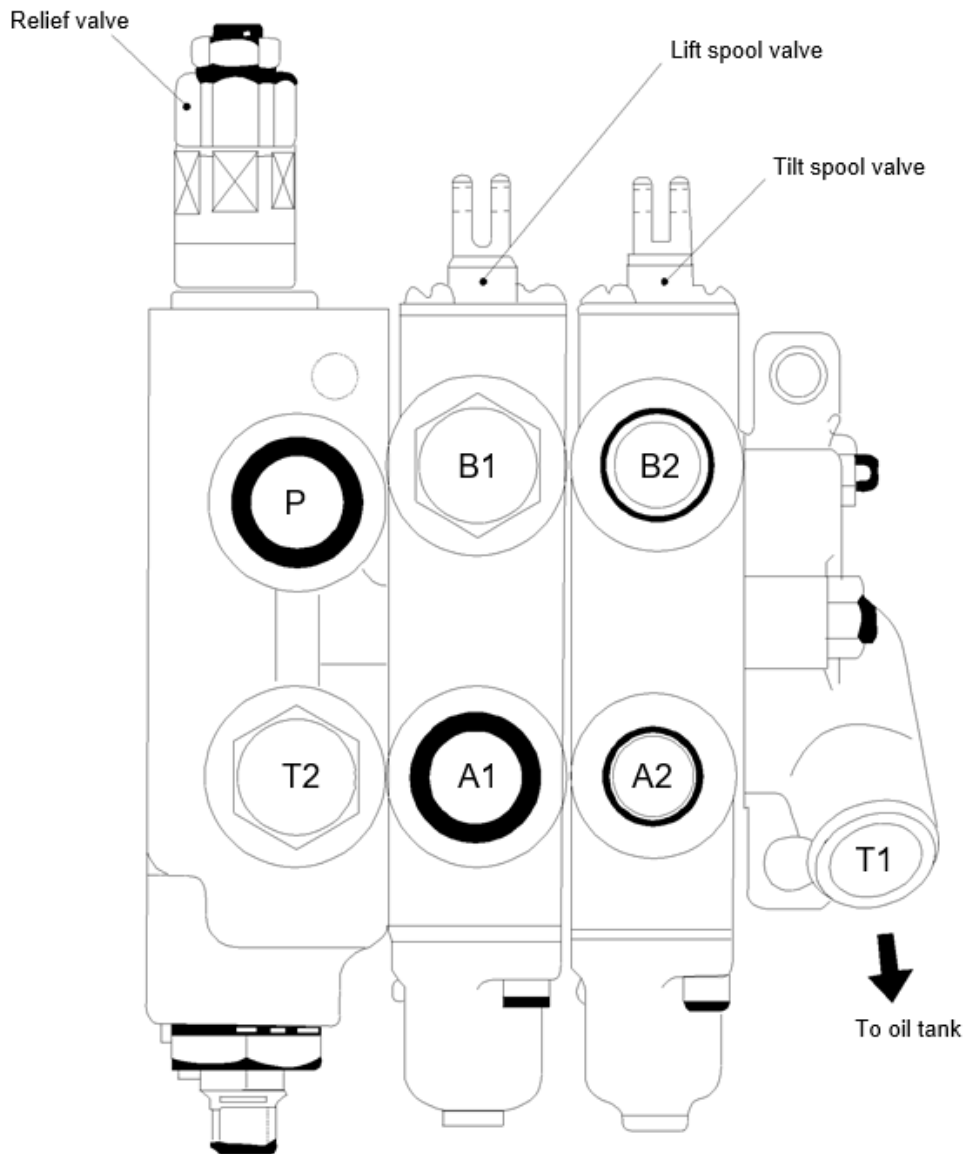

Fig.5-2 Control valve

(1) Spool Operation (using the tilt spool valve as an example)

(a) Neutral Position

In the neutral position, high-pressure oil from the lift pump returns to the oil tank via the mid-passage.

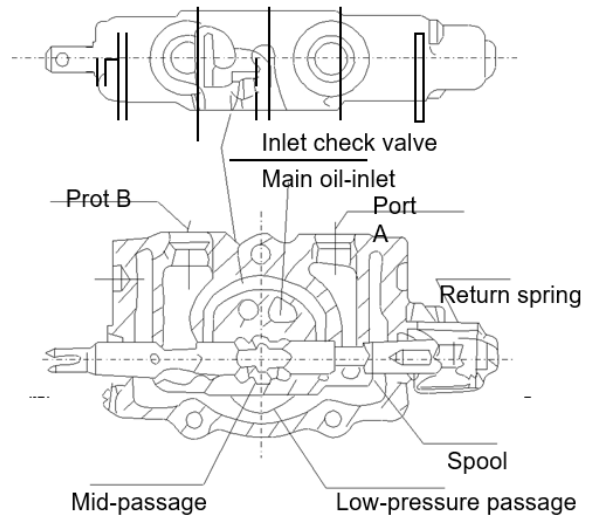

Fig.5-3

(b) Pushing the Spool In

When the spool is pushed in, it closes the mid-passage. This action allows oil from the main oil inlet to lift the inlet check valve and flow into port “B.” The return oil from port “A” then moves through the low-pressure passage back to the tank, while the return spring restores the spool to its neutral position.

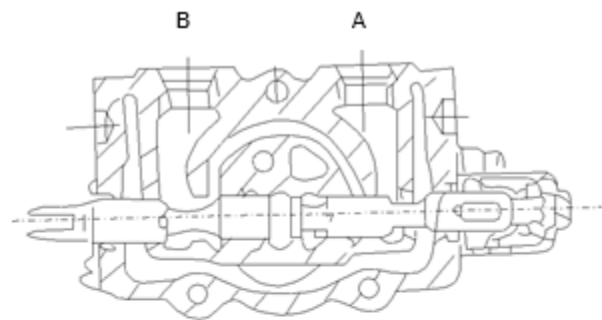

Fig.5-4

(c) Pulling the Spool Out

With the mid-passage closed, oil from the main oil inlet lifts the check valve and flows into port “A.” The return oil from port “B” travels through the low-pressure passage to the tank, and the return spring returns the spool to its neutral position.

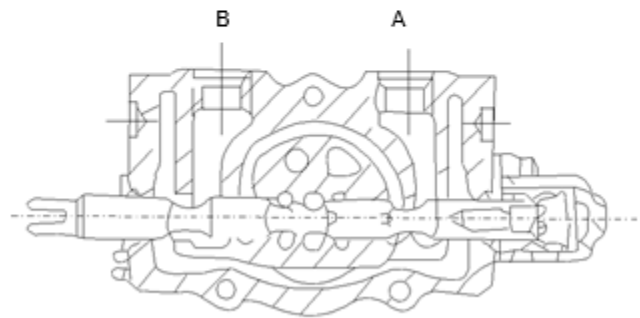

Fig.5-5

(2) Relief Valve Action

An overflow valve is situated between port “HP” of the pump and low-pressure port “LP.” Oil flowing through the tilt valve acts on the different diameter areas “A” and “B.” As a result, both the check valve “K” and the tilt valve “D” are pressed down onto their valve seats. (See Picture 5-6.)

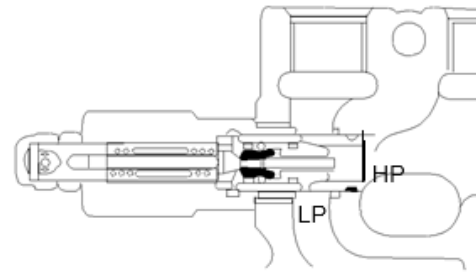

Fig.5-6

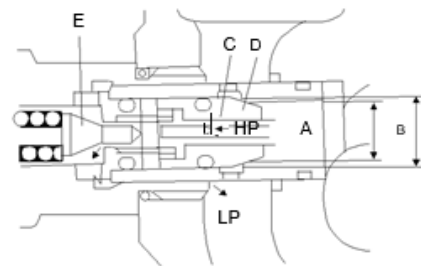

Fig.5-7

The adjusted pressure in the “HP” passage of the pump exerts force on the spring of the guided valve, causing the check valve “E” to open. (Refer to Picture 5-7.)

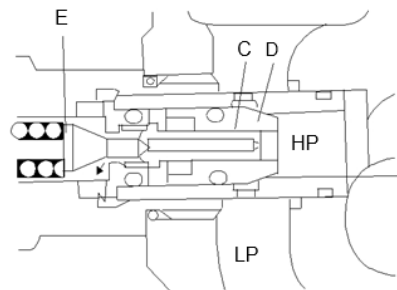

Fig.5-8

Once the guided valve “E” opens, the pressure on the side of valve “C” decreases, causing both valves “E” and “C” to settle onto their seats. This leads to a reduction in internal pressure. (See Picture 5-8.)

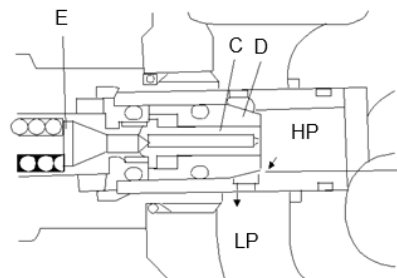

Fig.5-9

(3) Action of Tilt-Lock Valve

The tilt spool valve housing incorporates a tilt-lock valve designed to prevent mast vibrations caused by negative pressure in the tilt cylinder and to mitigate risks associated with improper handling of the spool. When the lift motor is not running, the mast cannot be tilted forward by pushing the tilt lever.

(A) Spool Pushed In

When the spool is pushed in, pressurized oil flows through port B to the tilt cylinder, activating the tilt-lock valve. This allows port A to connect to the low-pressure tank, enabling the tilt cylinder and mast to tilt forward.

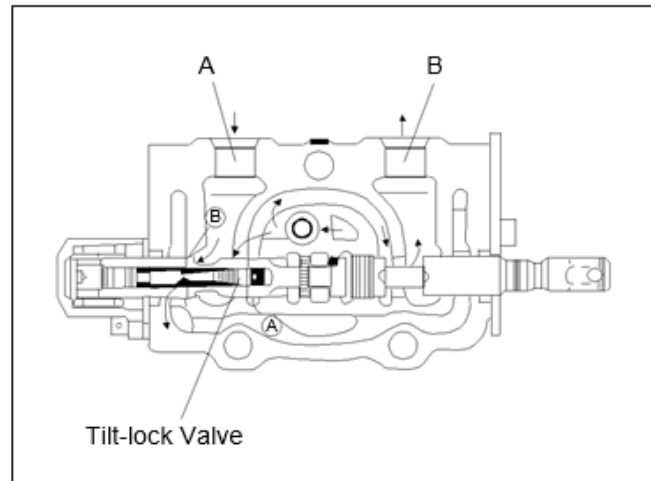

Fig.5-10

(B) Spool Pushed In (When the Lift Motor Stops)

When the lift motor stops, no pressurized oil flows to the tilt-lock valve. As a result, port A cannot connect to the low-pressure tank, preventing the mast from tilting forward.

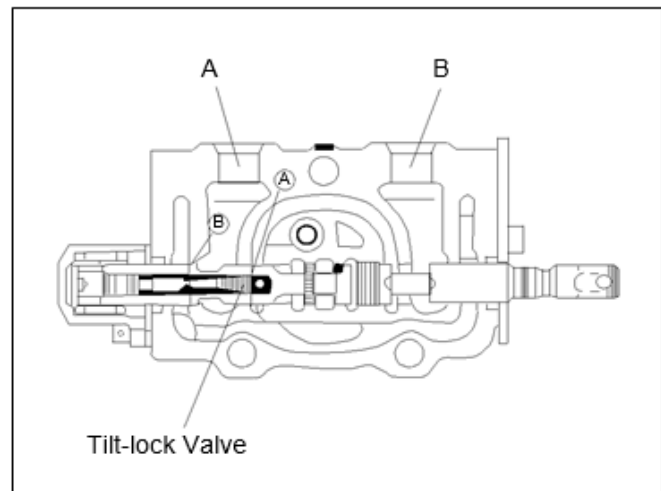

Fig.5-11

(4) Operation of the Control Valve

The control valve is operated using valve levers. All valve levers are mounted on a shaft, which is secured to the front guard with a bracket. The levers work together to control the operation of the valve.

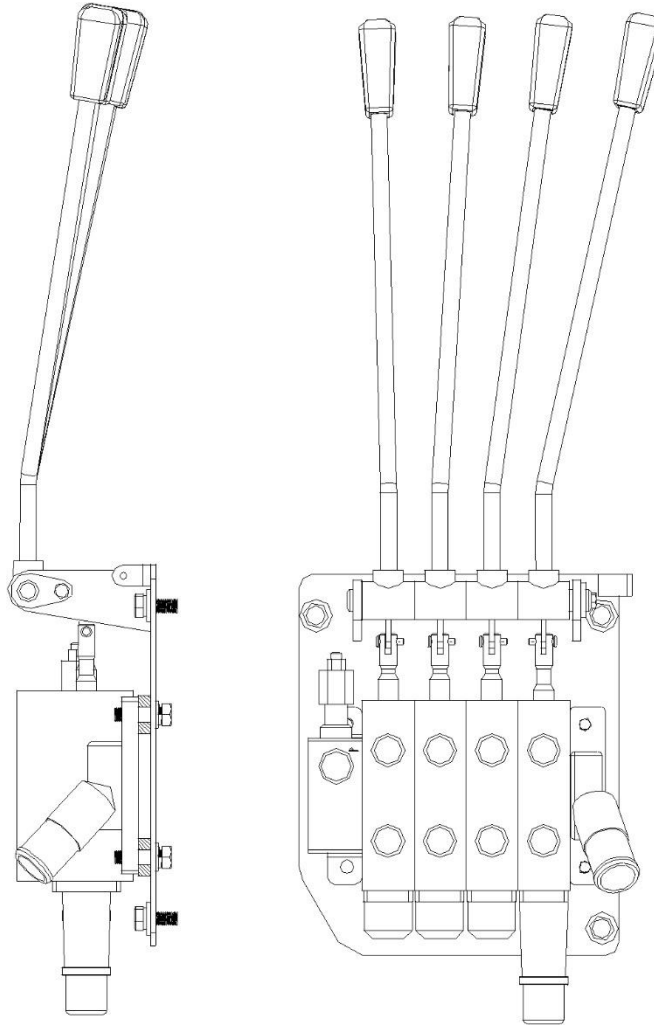

Fig. 5-12 Operation of the control valve

(5) Setting pressure

Specification	2-2.5t	3-3.5t
Main Relief Pressure	18.5 MPa	20 MPa
Steering Unit Pressure	6.3 MPa	6.3 MPa

4. Lifting Cylinder

The single-acting type lift cylinder combines the cylinder body, piston, piston rod, cylinder cap, cylinder base, and oil seals.

The bottom of the lifting cylinder is fixed to the outside bracket using a pin and bolt; the top of the cylinder (the top of the piston rod) is connected to the beam on the outside bracket.

The piston is fixed to the piston rod by an elastic spring; the outer ring of the piston is equipped with an oil seal and a back-up ring.

There is a cut-off valve at the bottom of the lifting cylinder (see Picture 10-11). In the event of a sudden crack in the high-pressure pipe, this valve prevents the load from falling sharply.

The cylinder end is equipped with a bearing and oil seal to support the piston and prevent the entry of dust.

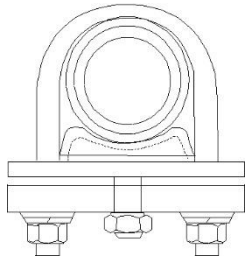

Cylinder Support

1. Top Rail
2. Spacer
3. Dust-Proof Ring
4. Oil Seal
5. Guide Sleeve
6. "O" Ring
7. Cylinder End
8. Steel Bearing
9. Cylinder Body
10. Piston Rod
11. Piston
12. Piston Oil Seal
13. Oil Seal
14. Seat Ring
15. Elastic Check Ring
16. Cut-Off Valve
17. Elastic Locking Ring
18. Cotter Pin
19. Locking Nut
20. Adjusting Nut
21. End Connector
22. Chain
23. Chain Wheel

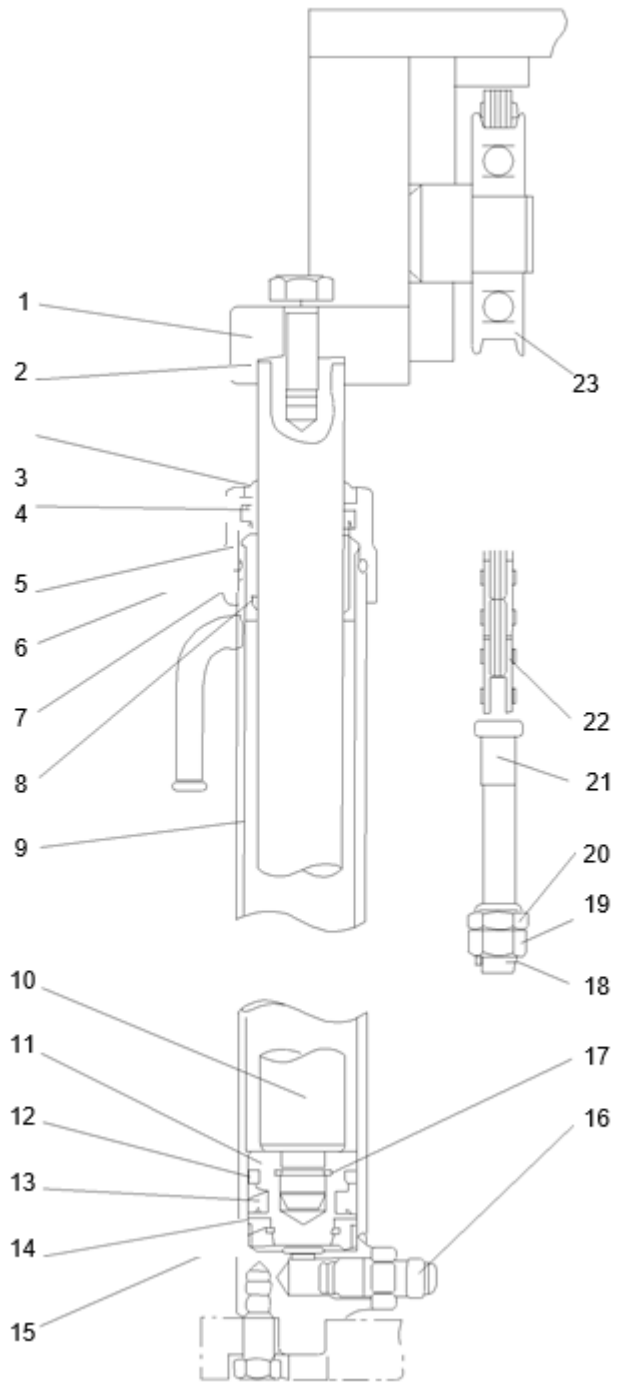

Fig. 5-13 Lifting Cylinder

Cut-off Valve Action

There is a cut-off valve that operates when the high-pressure hose bursts for any reason, preventing the load from dropping abruptly at the bottom of the lift cylinder. The oil from the lift cylinder flows through small holes in the circumference of the cut-off valve spool, creating a pressure difference between two chambers.

As the pressure difference resulting from the passing oil through the holes is smaller than the spring force, the cut-off valve spool remains in place. However, if the high-pressure hose bursts, the pressure difference becomes large enough to overcome the spring force, causing the spool to move.

This movement blocks the holes on the circumference of the spool, allowing only a small amount of oil to flow through the holes at the spool end. This design enables the forks to descend at a controlled, low speed.

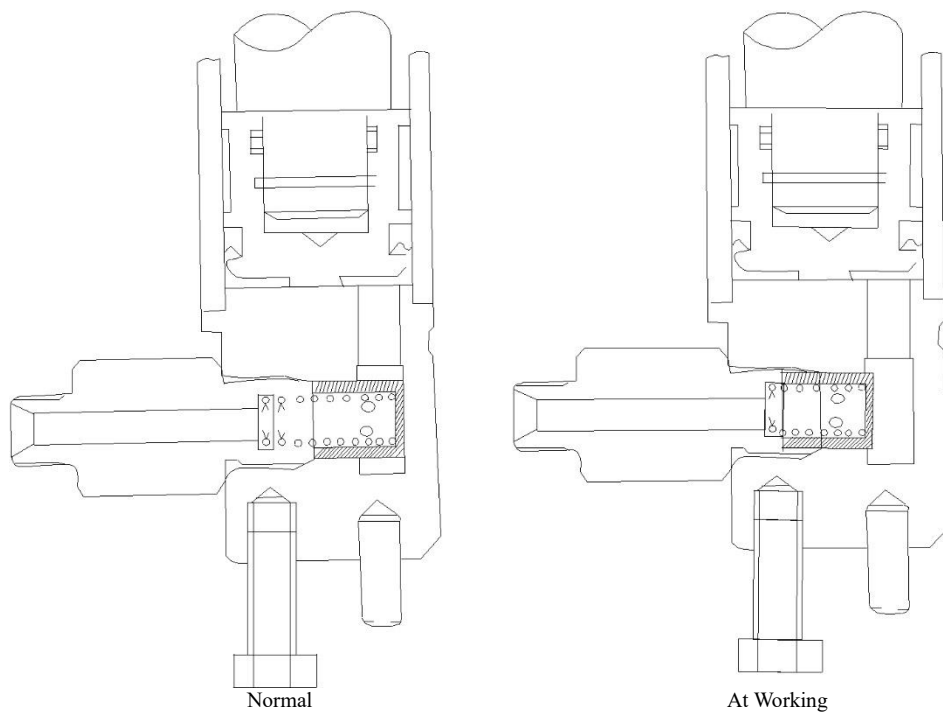

Fig. 5-14

5. Flow Regulator Valve

The flow regulator valve controls the descending speed of the forklift and acts as a safeguard in the event of a high-pressure hose rupture.

See picture 5-15

Working Situation of Flow Regulator Valve (see picture 5-16)

The return oil from the lift cylinder enters the valve cavity "G" and flows back to the control valve through passages "F," "E," "D," "C," "B," and "A." When a large volume of oil flows through the valve core "C," the pressure difference causes the valve core "C" to move to the right. This narrows the passage between holes "D" and "C," reducing the volume of return oil and slowing the forklift's descent speed.

To lift the forklift, high-pressure oil from the control valve enters the lift cylinder through passages "A," "B," "C," "D," "E," "F," and "G."

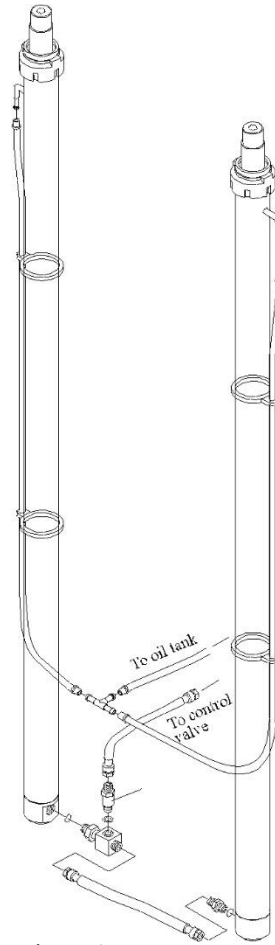

Fig. 5-15

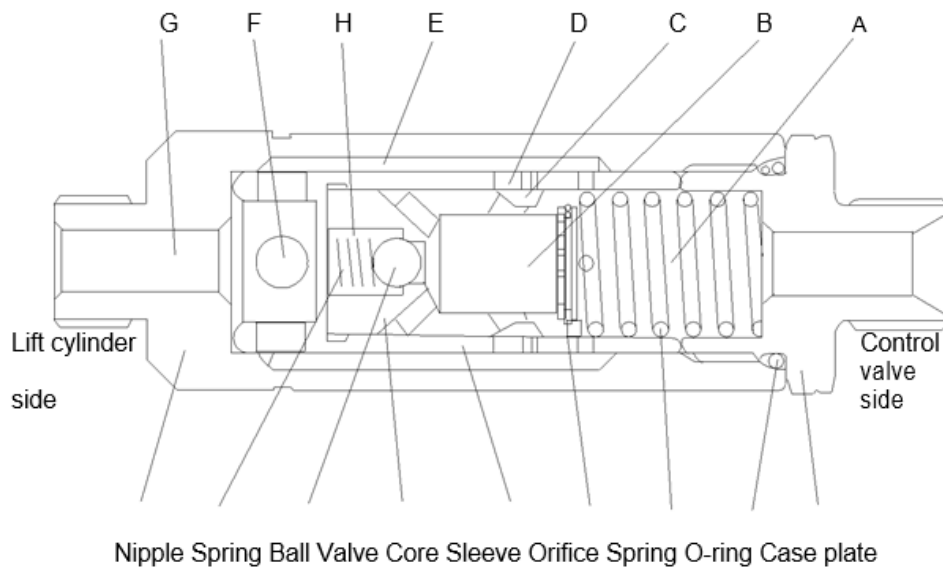

Fig.5-16 Flow regulator valve

6. Tilt Cylinder

The tilt cylinder is of a double-acting type. Each forklift has two tilt cylinders installed on either side of the frame with pins, while the piston rod ends are connected to the outer mast.

The tilt cylinder primarily consists of a piston, piston rod, cylinder body, cylinder base, guide sleeve, and seals. The piston, welded to the piston rod, is equipped with two Yx-rings and one wear ring around its circumference. A bushing, press-fitted to the inner side of the guide sleeve, supports the piston rod. The guide sleeve includes a dust seal, nap ring, Yx-ring, and O-ring to prevent oil leakage and keep dust out. With these components fitted, the guide sleeve is screwed into the cylinder body.

When the tilt lever is pushed forward, high-pressure oil enters the cylinder body from the cylinder tail, moving the piston forward and causing the mast assembly to tilt forward up to 6 degrees. When the tilt lever is pulled backward, high-pressure oil enters the cylinder body from the guide sleeve, moving the piston backward and tilting the mast assembly backward up to 12 degrees.

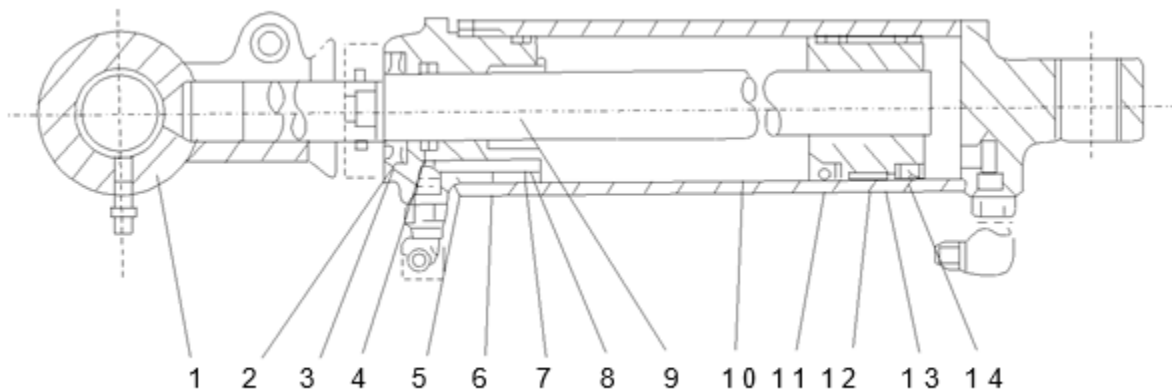

Fig.5-17 Tilt Cylinder

1. Ear Ring	2. Dust Seal	3. Snap Ring	4. Yx-Ring
5. O-Ring	6. Guide Sleeve	7. Bushing	8. O-Ring
9. Piston Rod	10. Cylinder Body	11. Yx-Ring	12. Wearing Ring
13. Piston	14. Yx-Ring		

7. Hydraulic Oil Tank

The hydraulic oil tank for 2-3.5t forklifts is installed on the backside of the battery group. An oil filter is located within the tank, and a returning oil filter is installed in the return oil circuit to ensure clean oil supply.

8. Hydraulic Oil Pipeline

For 2-3.5t forklifts, refer to picture 5-18 for the hydraulic oil pipeline.

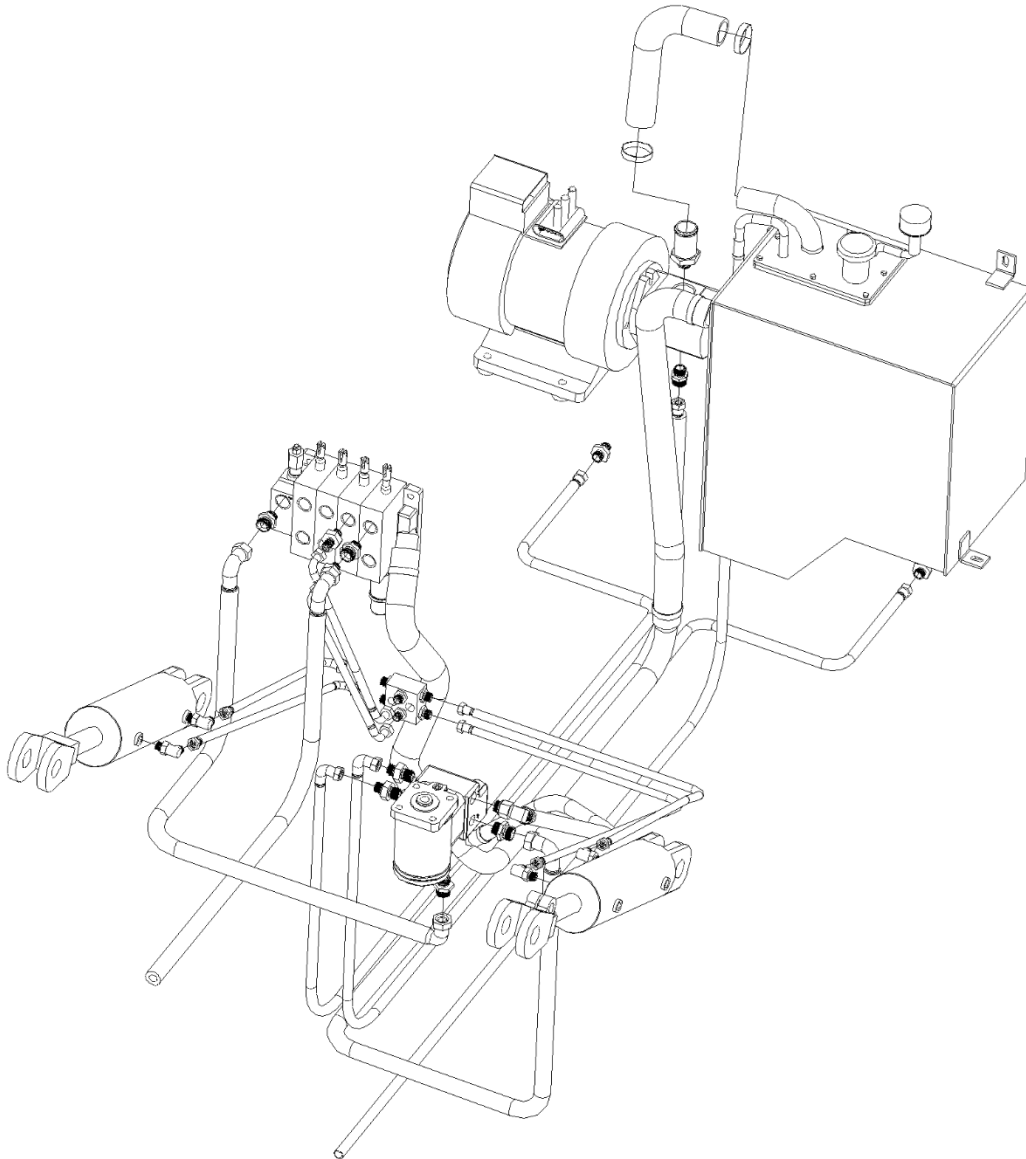

Fig. 5-18 Hydraulic Oil Circuit (2-3.5ton)

9. Maintenance of Lift Pump

(1) Disassembly

Before disassembling the pump, place the removed parts on paper or cloth to avoid damage.

(A) Hold the pump securely in a vice by lightly clamping the flange section.

(B) Remove bolts 11, the pump cover 5, and the pump body 1.

(C) Remove bushing 6, drive gear 2, and driven gear 3.

(D) Remove the seal ring and packing ring from the front or rear cover.

Note: Do not remove the seal ring and packing ring from the front or rear cover if they do not need replacement.

(2) Inspection

Inspect the disassembled parts and clean them with light oil. Do not wash rubber components with light oil.

(A) Body Inspection

If the scraping trace exceeds half the length of the inner circumference, replace the pump body.

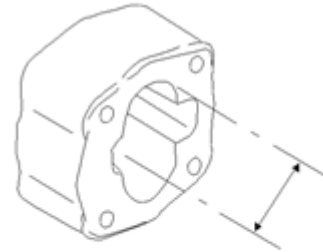

Fig.5-20

(B) Scale Board Inspection

Replace the scale board if its surface is damaged or if the thickness is less than the standard value.

Standard Thickness: 4.94 mm

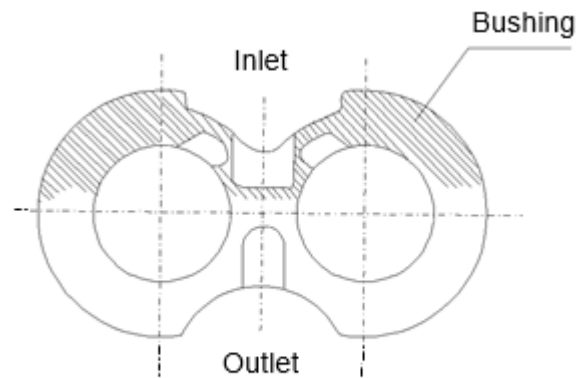

Fig.5-21

(C) Front and Rear Pump Cover Inspection

Replace the front and rear pump covers if the lining of the inner surface changes color (to brown) and exceeds a thickness of 150.



Fig.5-22

(D) Drive Gear and Driven Gear Inspection

Inspect the drive gear and driven gear from both the front and rear. If abrasion is excessive, replace with a new pair. If the size D is smaller than the standard value, replace several pairs.

Standard Size D: 20.961 mm

(E) Seal Replacement

Replace the seal ring, the seal component of the lining, the check ring, the oil seal, and the spring check ring as necessary.

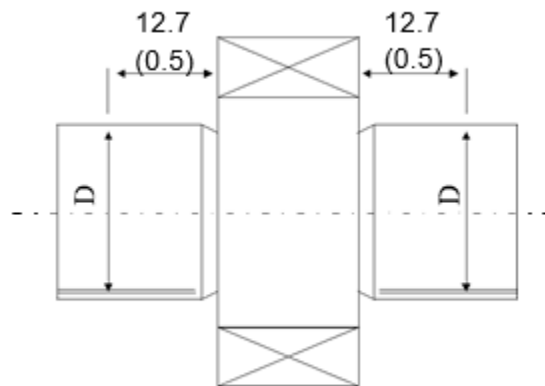

Fig.5-23

(3) Assembly

(a) Install a new seal ring and a new check ring on the front cover of the pump.

(b) Install the scale board in the groove of the front cover; ensure not to confuse the suction inlet with the oil outlet.

(c) Install the driven gear onto the front cover.

(d) Position the scale board on the side of the gear, aligning the groove with the gear point. Do not confuse the oil inlet side with the oil outlet side.

(e) Install a new seal ring and check ring in the groove of the rear cover.

(f) Attach the rear cover to the pump, ensuring not to confuse the oil inlet and oil outlet.

(g) After assembly is complete, tighten the connecting bolts to the standard torque of 9-10 kg·m.

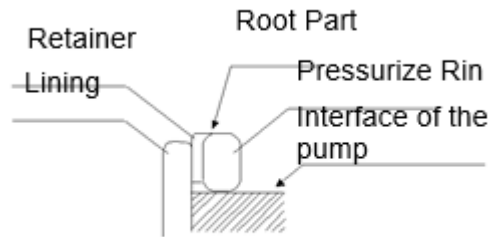

Fig.5-24 Lining seal cap

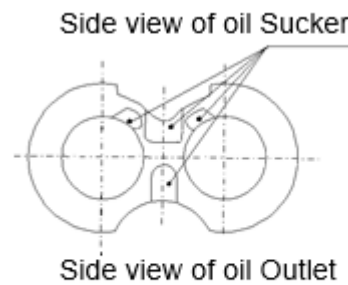

Fig.5-24 Scale board

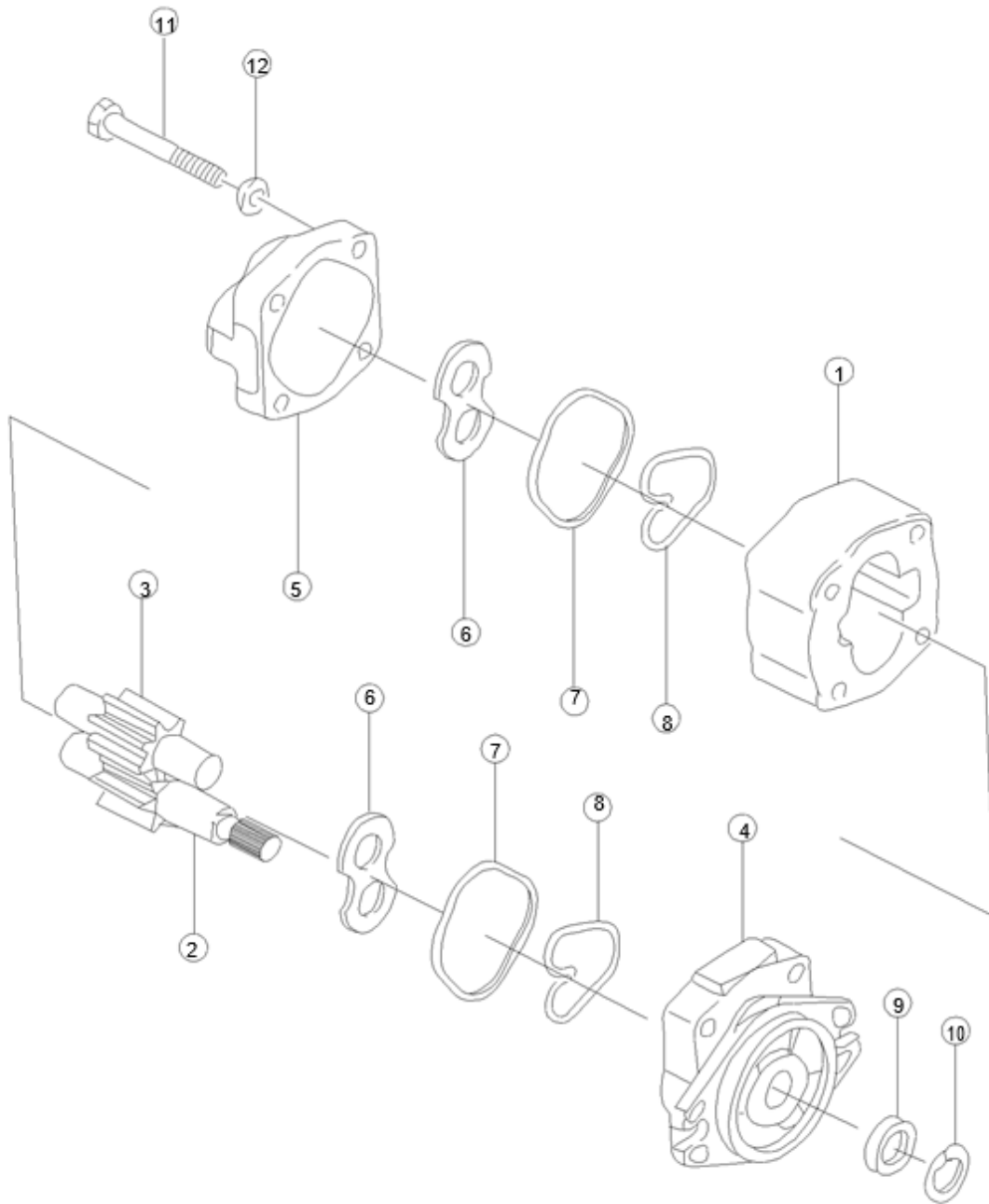

Fig.5-26 Gear pump

1. Pump body	7. Seal ring
2. Driven Gear	8. Check ring
3. Drive Gear	9. Oil seal
4. Front End Cover	10. Elastic check ring
5. Backend Cover	11. Bolts
6. Scaleboard	12. Washer

(4) Pilot Operation

The pilot operation runs the oil pump to check for normal operation.

Conduct the oil pump examination on the test bench and evaluate the pump on the forklift following these procedures:

(If the oil pump has been disassembled and repaired due to severe damage caused by hydraulic oil, ensure that the hydraulic oil and filter are replaced before operating the pump on the forklift.)

- (a) Install the pump on the forklift and attach the pressure gauge to the pressure detection outlet of the selector valve.
- (b) Loosen the overflow valve and adjust the screw. Run the pump for about ten minutes, ensuring the oil pressure is below 10 kg/cm².
- (c) Increase the pump speed to 1500-2000 RPM and run for approximately ten minutes.
- (d) Maintain the pump speed at 1500-2000 RPM and gradually increase the pressure to 20-30 kg/cm². The pump should run for five minutes until reaching 175 kg/cm². Then, operate each oil pathway for five minutes and change the strainer.

While increasing the oil pressure, monitor the temperature of the oil, the surface temperature of the pump, and the operating sound. If the temperature of the oil or pump surface becomes too high, reduce the load to lower the oil temperature and continue testing.

- (e) After the experiment, set the overflow pressure to 175 kg/cm² and measure the flow rate; the quantity of oil can be assessed through the lifting speed.

10. Troubleshooting

If the hydraulic system malfunctions, identify the cause and implement the necessary repairs.

(1) Selector Valve

Malfunction	Reason	Repairing Method
Lifting oil pressure cannot be increased	Slide valve jammed	Disassemble and clean
	Oil hole blocked	Disassemble and clean
Jolt and slow lifting pressure	Slide valve jammed	Disassemble and clean
	Insufficient air exhaust	Fully discharge air
Steering oil pressure exceeds standard value	Slide valve jammed	Disassemble and clean
	Oil hole blocked	Disassemble and clean
Standard oil quantity not reached	Improper overflow valve adjustment	Adjust
Noise present	Improper overflow valve adjustment	Adjust
	Damaged slide surface	Replace overflow valve
External oil leak	O-ring aging or damaged	Replace O-ring

Malfunction	Reason	Repairing Method
Low pressure	Damaged spring	Replace spring
	Damaged valve surface	Adjust or replace overflow valve
Internal oil leak	Damaged valve surface	Repair valve surface
High pressure	Jammed valve door	Disassemble and clean

(2) Oil Pump

Problem	Possible Cause	Remedies
Oil can't be pumped out	Low oil level in the tank	Add oil up to the specified level
	Blocked pipeline or oil filter	Clean or replace, especially if contaminated
Gear pump cannot be pressurized	Worn bushings 3 and 4 or damaged packings 9, 10, 11	Replace
	Misadjusted relief valve	Adjust the pressure of the relief valve; monitor the pressure gauge while increasing pressure
	Loose connections on the suction pipe	(1) Retighten loose connections
		(2) Add oil to the oil tank
(3) Check oil seal		
(4) Do not start the pump until there are no air bubbles in the oil tank		
Noisy gear pump	Twisted suction hose or cavitations due to blocked oil filter	Correct hose position and clean the filter
	Air entering due to loose suction connections	Retighten each connection
	Excessively high oil viscosity	(1) Use oil with proper viscosity
		(2) Start the pump only when the oil is at normal temperature
	Air bubbles in oil	Identify and correct the cause
Eccentrically mounted gear pump	Re-mount gear pump concentrically	
Oil leakage in pump	(1) Oil seal and packing 8 in pump broken down (2) Worn sliding surfaces (increased internal leakage)	Repair or replace as necessary

Lifting System

1. General Description

The lifting system is a two-stage design, consisting of the inner mast, outer mast, and lift bracket.

2. Inner and Outer Masts

Both the inner and outer masts are welded components. The bottom of the outer mast is connected to the drive axle, while the outer mast's middle section is connected to the frame via tilt cylinders. The mast assembly can tilt forward and backward by operating the tilt cylinders. The outer mast features a C-shaped cross-section, with main rollers and side rollers mounted at the top. The inner mast has a J-shaped cross-section and is equipped with main rollers and side rollers at its base.

Maintenance of the rollers and side rollers on both the inner and outer masts is classified as elevated maintenance; please exercise caution.

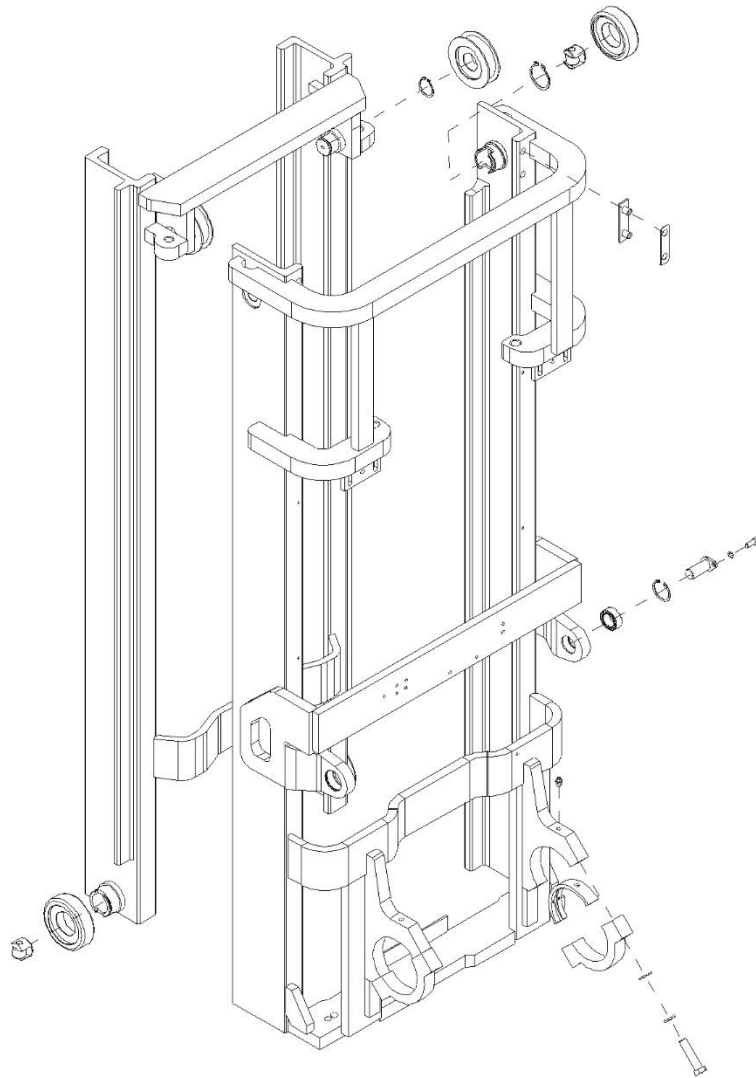

Fig.6-1 Inner and outer masts

3. Lift Bracket

The lift bracket moves smoothly up and down along the channel of the inner mast using main rollers. Each main roller is secured to its axis by a snap ring, and the axis is welded to the lift bracket. The side rollers are attached to the lift bracket with bolts. Main rollers support the longitudinal loads, while side rollers handle the transverse loads. When the forks reach their maximum height, the upper pair of main rollers will exit the top of the inner mast.

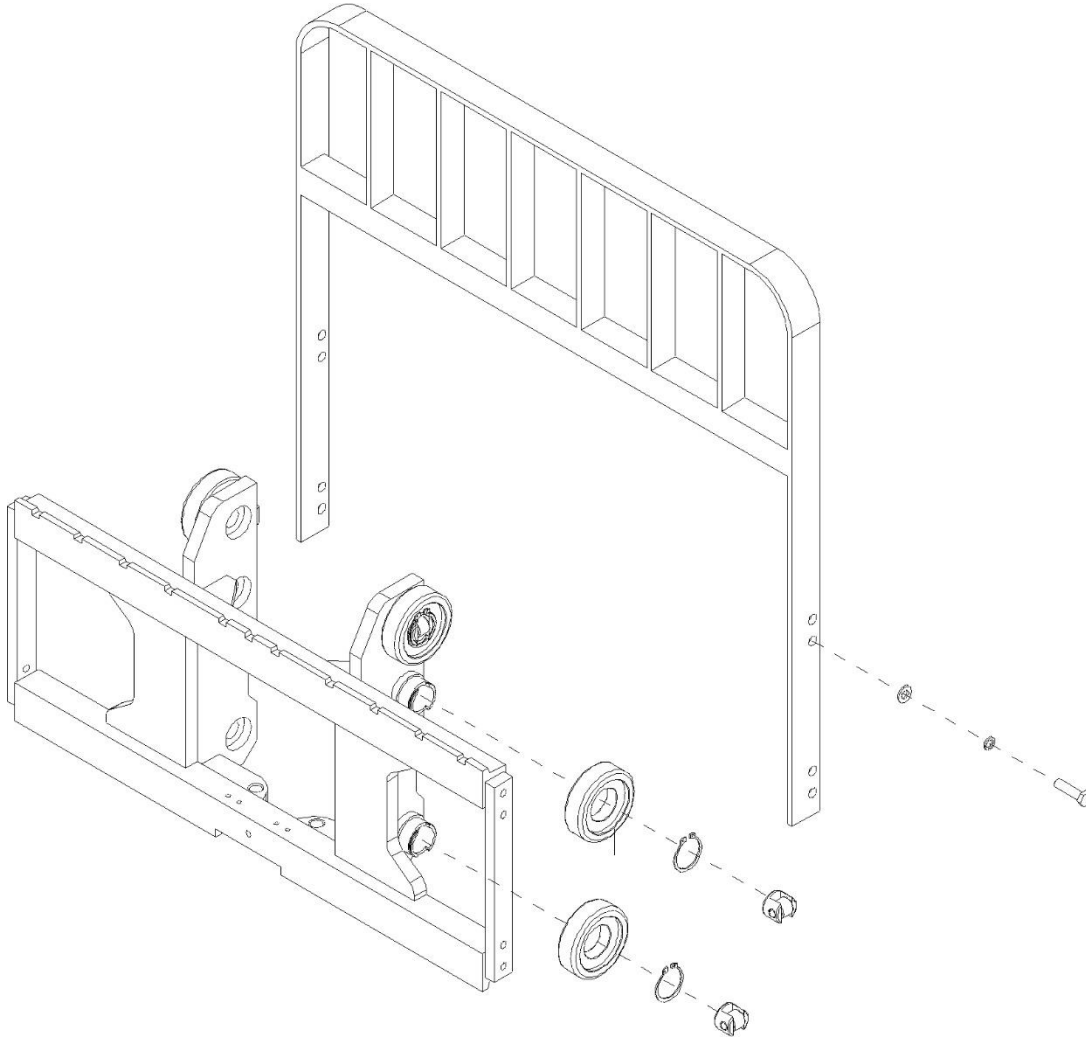

Fig.6-2 Lift bracket

4. Layout of Rollers

There are two types of rollers: main rollers and side rollers. Both types are installed on the outer mast, inner mast, and lift bracket. The main rollers and side rollers work together to support longitudinal and transverse loads, allowing the inner mast and lift bracket to operate smoothly.

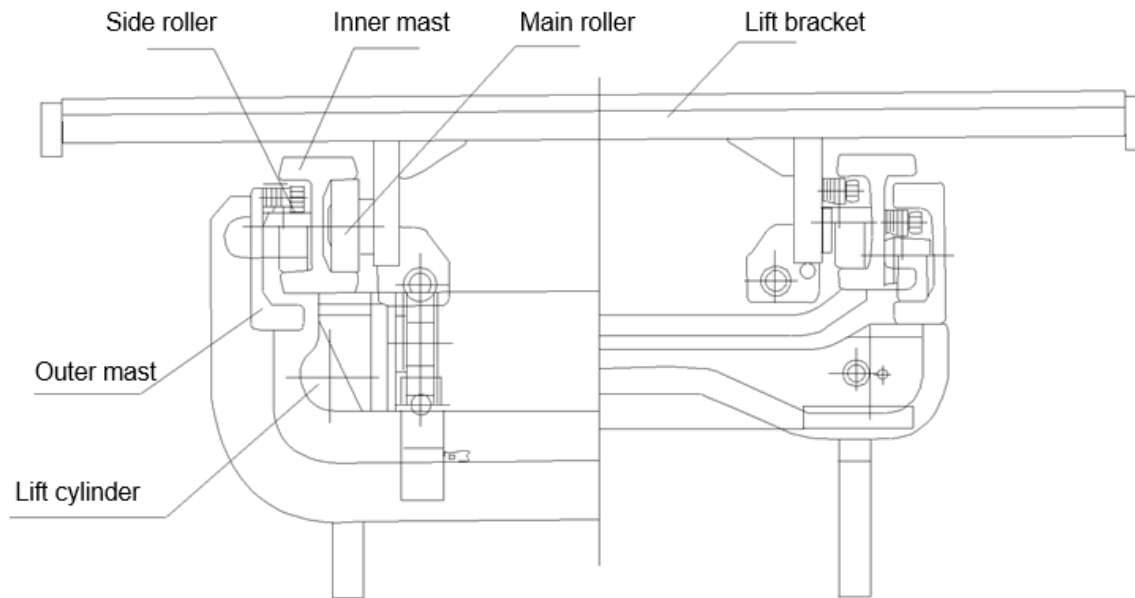

Fig.6-3 Position of rolls

Attention

(A) The clearance of the side roller is 0.5 mm.

(B) Please apply grease to the surface of the main rollers and the interface of the masts.

5. Adjust Lift Cylinder

The stroke of the lift cylinder must be readjusted when the lift cylinder, inner mast, or outer mast is replaced. Follow these steps:

- (1) Place the piston rod heads into the upper beam of the inner mast without shims.
- (2) Ensure that both lift cylinders operate simultaneously when the mast reaches its maximum stroke.
- (3) If they do not lift synchronously, add shims between the upper beam of the inner mast and the piston rod head of the cylinder that reaches its maximum stroke. The shims should be either 0.2 mm or 0.5 mm thick.
- (4) Adjust the tightness of the lift chains. Note that adjusting the lift cylinder is classified as elevated maintenance; please exercise caution.

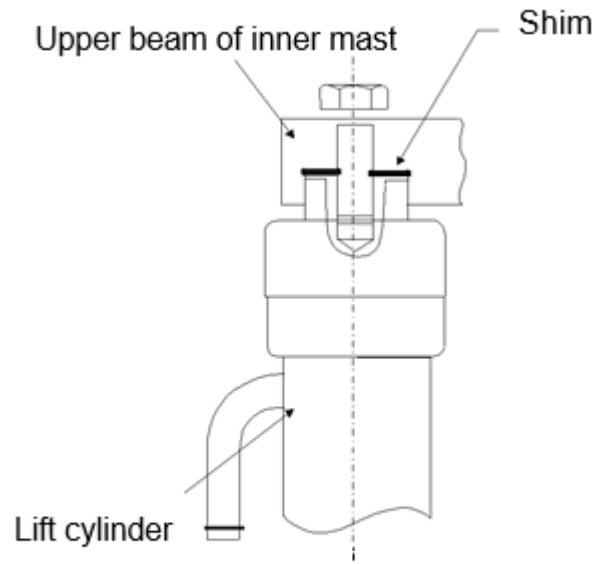

Fig.6-4

6. Adjust Lift Bracket Height

- (1) Ensure the truck is stopped on level ground, with the masts fully upright.
- (2) Lower the forks to the ground and adjust the set nut of the tie-in at the top of the chains to ensure the specified distance A between the main rollers and the lift bracket.

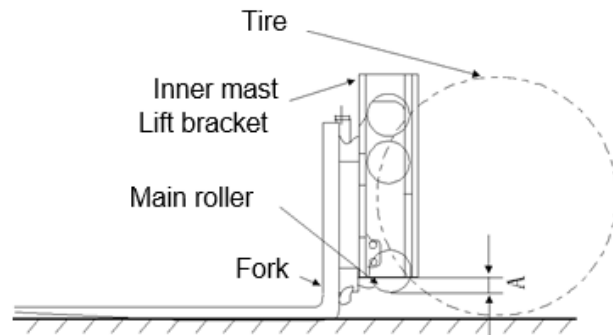

Fig.6-5

Type of forklift	A mm
2-2.5t	24-29
3-3.5t	19-24

(3) Tilt the mast assembly backward as the forks descend to the ground. Adjust the pulling force of the lift chains to ensure that their tightness is equal.

7. Replacing Rollers of the Lift Bracket

(1) Place a tray on the forks and ensure the forklift is parked on level ground.

(2) Lower the forks and tray to the ground.

(3) Remove the tie-in at the top of the chains and take the chains out from the sheave.

(4) Raise the inner mast.

(5) The forklift can be reversed once the lift bracket is disengaged from the outer mast.

(6) Replacing Main Rollers:

(a) Remove all snap rings from the lift bracket and take out the main rollers.

(b) Install the new main rollers (ensure they are the same type as the old ones) on the lift bracket and secure them with snap rings.

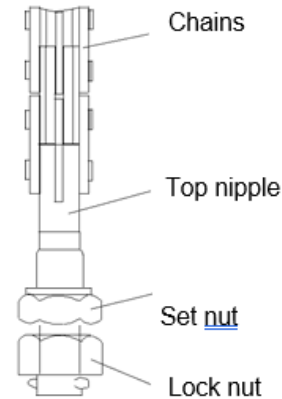

Fig.6-6

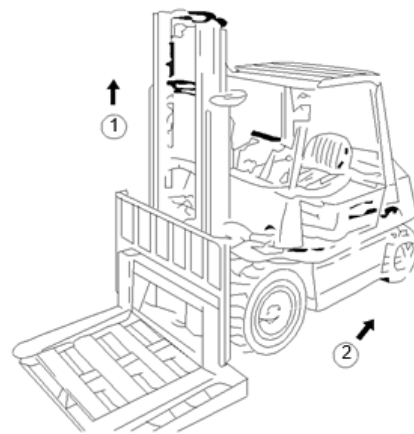

Fig.6-7

8. Replacing Rollers of Masts

(1) Remove the fork bracket from the inner mast, then replace the main rollers as described in section 6.2.3.

(2) Park the truck on level ground and lift the front wheels 250–300 mm off the ground.

(3) Fully engage the parking brake and use a wedge to secure the back wheels.

(4) Remove the bolts that secure the lift cylinders to the inner mast. Carefully hang the inner mast without losing the shims of the piston rod heads.

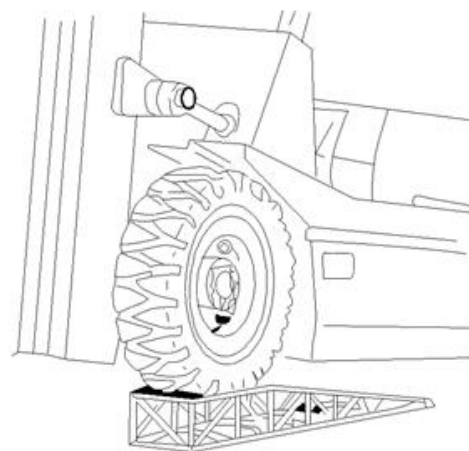

Fig.6-8

(5) Remove the bolts that connect the lift cylinders to the bottom of the outer mast and detach the oil pipe between the two lift cylinders without losing the nipple.

(6) Once the main rollers are removed from the bottom of the inner mast and the inner mast is laid down, the main rollers on the upper outer mast will become visible at the top of the inner mast.

(7) Replacing Main Rollers:

(A) Remove the upper main rollers without losing the shims.

(B) Install the new main rollers and shims onto the outer mast.

(8) Raise the inner mast and ensure all rollers are properly positioned within the inner mast.

(9) Reassemble the lift cylinder and lift bracket by reversing the disassembly steps.

Here's a revised version of the maintenance section for the battery forklift:

Battery Forklift Maintenance

To ensure optimal performance and longevity of the forklift, operate it carefully, make necessary adjustments, and maintain it in good working condition. The following measures should be taken:

(1) Replace the differential and gear oil in the reducer after the first 100 hours of operation for a new forklift, and ensure all components are tightened securely.

(2) Readjust the clearance between the drive gear and driven gear in the reducer after the first 200 hours of operation for a new forklift.

(3) Perform maintenance and service according to the instruction manual for the motor, controller, and battery group.

(4) Inspect all components at least once a month.

(5) Ensure waterproofing measures are in place; avoid washing with a pressure washer and refrain from using the forklift outdoors during rainy conditions.

(6) Clean the lift switch regularly to remove dirt and debris.

(7) Keep the surface of the battery dry and clean.

(8) After operation, follow the maintenance schedule outlined in the table below:

Sequence Number	Item	Maintenance	Period of Maintenance	Remark
1	Steering Wheel	Replace lubrication bearing	1000 hours	
2	Drive Wheel	Replace lubrication bearing	1000 hours	
3	Steering Rod	Replace lubrication	1000 hours	
4	Hand Brake Moving Point	Add lubrication	200 hours	
5	Foot Brake Pin	Add lubrication	200 hours	
6	Drive Axle	Replace gear oil	2400 hours	
7	Brake Lubrication	Add	Any time	
8	Tilt Cylinder Bearing	Add lubrication	400 hours	
9	Knuckle Main Pin	Replace lubrication	1000 hours	
10	Hydraulic Oil Tank	Clean and filter	1000 hours	
11	Hydraulic Oil	Replace	1000 hours	
12	Lifting Hinge	Replace	4800 hours	Replace any time when damaged
13	High-Pressure Tube	Replace	4800 hours	Replace any time when damaged
14	Lifting Switch	Remove dirt	200 hours	
15	Drive Motor's Charcoal Bush	Check	1000 hours	
16	Lifting Motor	Check	1000 hours	
17	Steering Motor	Check	1000 hours	