

Part List

EK13-130 Series Counter Balanced Stacker

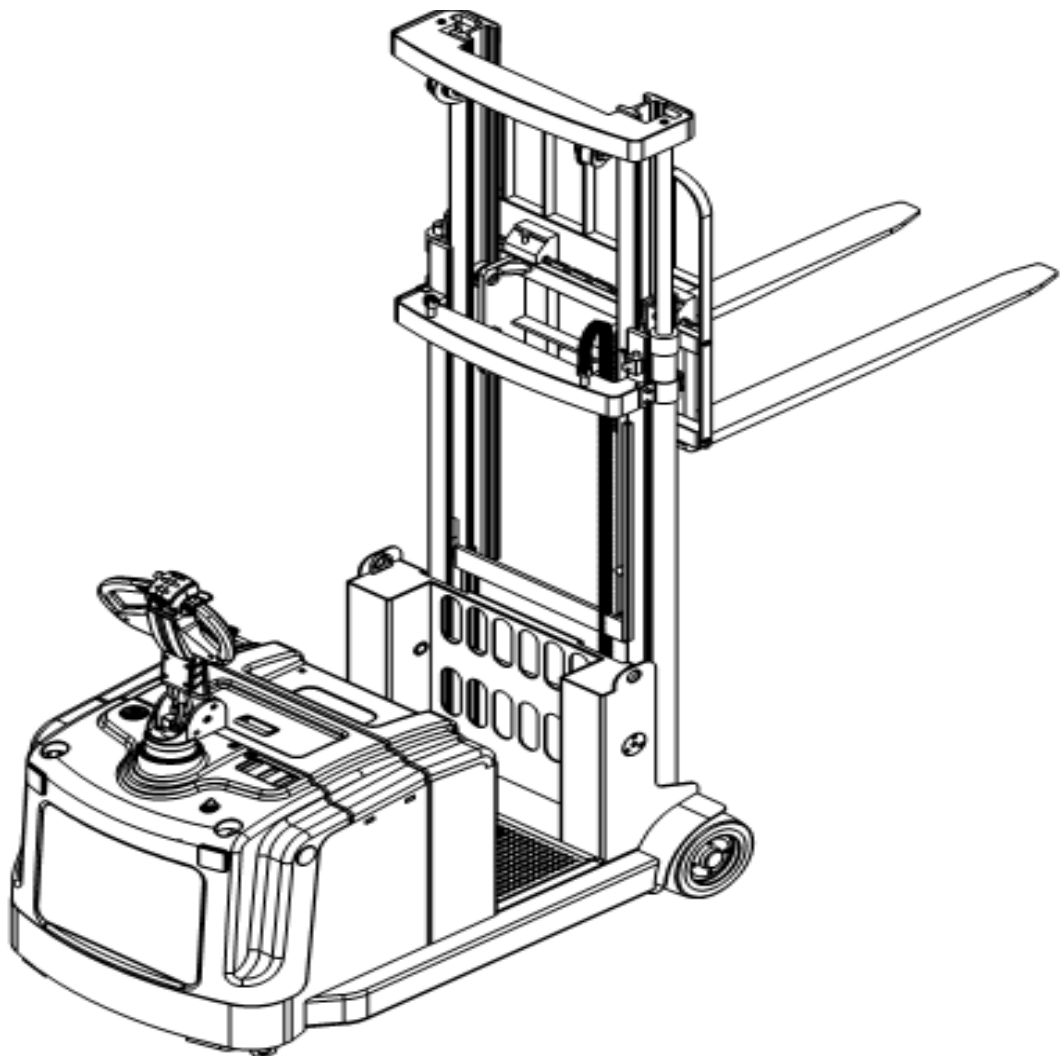

EKKO MATERIAL HANDLING EQUIPMENT MANUFACTURING, INC.

Contents

1.THE FRAME ASSEMBLY	- 2 -
1.1 THE FRAME ASSEMBLY	- 2 -
1.2 EXTERNAL COVER ASSEMBLY	- 4 -
1.3 BATTERY CARRIAGE	- 5 -
2.DRIVING ASSEMBLY	- 6 -
2.1 DRIVING ASSEMBLY	- 6 -
3.HANDLE ASSEMBLY	- 7 -
3.1 HANDLE ASSEMBLY	- 7 -
4.FRAME ASSEMBLY	- 9 -
4.1 FRAME ASSEMBLY	- 9 -
4.2 OUTER FRAME COMPONENTS	- 11 -
4.3 INNER FRAME COMPONENTS	- 13 -
4.4 CARRIAGE COMPONENTS	- 15 -
4.5 FRAME ASSEMBLY (THREE MAST OF FULL FREE)	- 16 -
4.6 OUTER FRAME ASSEMBLY (THREE MAST OF FULL FREE)	- 18 -
4.7 MIDDLE FRAME ASSEMBLY (THREE MAST OF FULL FREE)	- 20 -
4.8 INNER FRAME ASSEMBLY (THREE MAST OF FULL FREE)	- 22 -
4.9 CARRIAGE COMPONENTS (THREE MAST OF FULL FREE)	- 24 -
5. HYDRAULIC SYSTEM	- 25 -
5.1 HYDRAULIC SYSTEM	- 25 -
6.ELECTRICAL ASSEMBLY	- 27 -
6.1 ELECTRICAL ASSEMBLY	- 27 -
6.2 DK1232-01 AC ELECTRONIC CONTROL COMPONENTS	- 29 -

1.The Frame Assembly

1.1The Frame Assembly

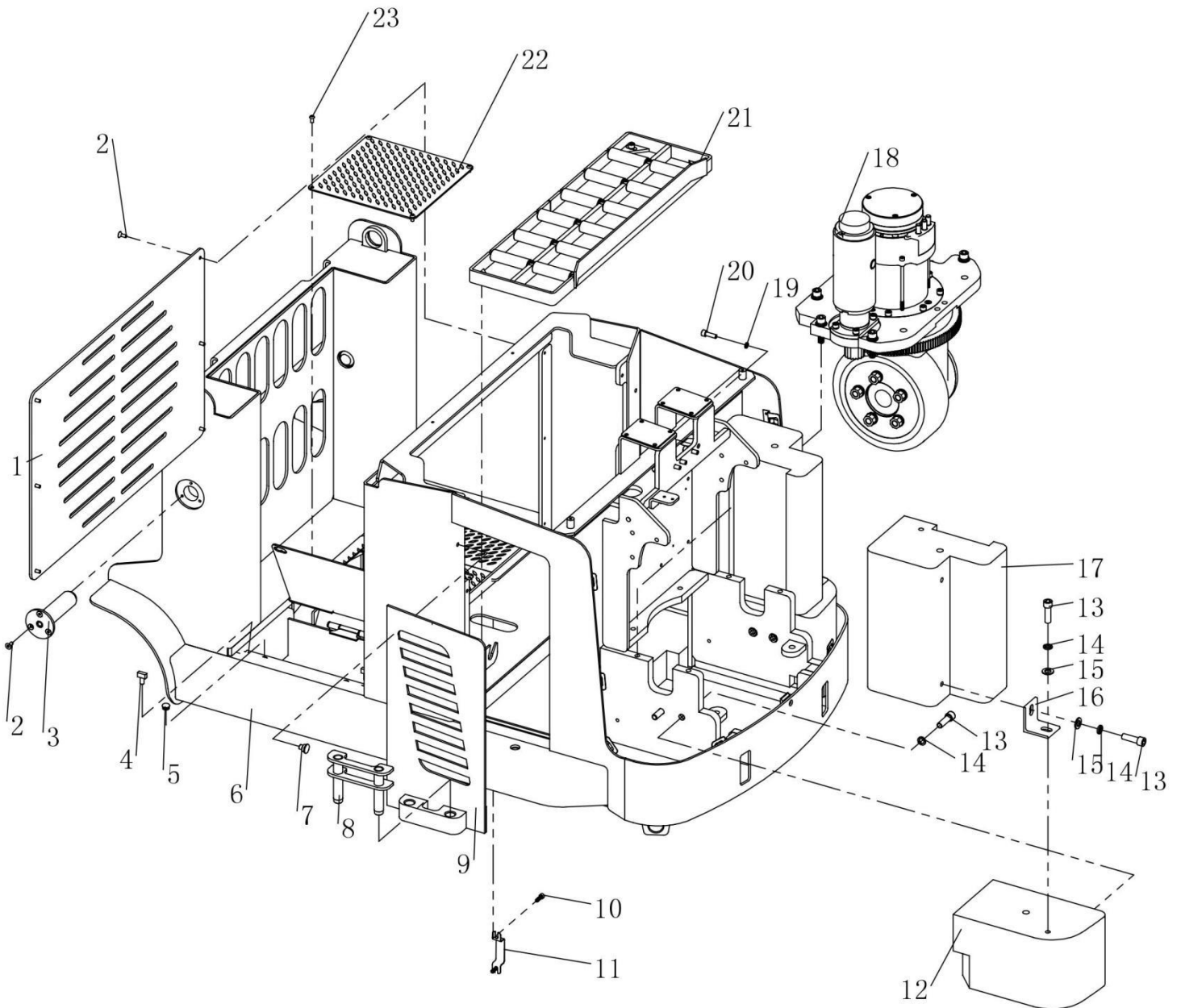

No.	Code No.	Name		Qty.	Note
1	EK13-01.18	Cove		1	
2	GB/T 70.3-2000	Hexagon socket countersunk head screws	M0.23×0.63	12	
3	EK13-01.8	Connection shaft welded for frame		2	
4	EK13-01.17	lock catch		4	
5		CL Rubber cover (small)		4	
6	EK13-01.1	Frame welded		1	
7	EK13-01.19	Card pin of battery		2	
8	EK13-01.10	Baffle card shaft welded		1	
9	EK13-01.3	Battery baffle (Left)		1	
10	GB/T 70.1-2000	Hexagon socket head cap screws	M0.23×0.8	2	
11	EK13-01.11	Clip		1	
12	EK13-01.23	Counterweight (3)		2	Symmetric one each
13	GB/T 70.1-2000	Hexagon socket head cap screws	M0.5×1.57	8	
14	GB/T 93-1987	Spring washer	Φ0.5	8	
15	GB/T 95-2002	Flat washer	Φ0.5	4	
16	EK13-01.26	Fixed Angle60×60×5		2	
17	EK13-01.24	Counterweight (4)		2	
18	EK13-01.9	Vertical drive electronic steering assembly.		1	
19	GB/T 93-1987	Spring washer	Φ0.3	4	
20	GB/T 70.1-2000	Hexagon socket head cap screws	M0.3×1	4	
21	EK13-01.5	Battery carriage		1	
22	EK13-01.16	Cover for Pedal plate		1	
23	GB/T 70.2-2000	Hexagon socket button head screws	M0.23×0.5	4	

1.2 External Cover Assembly

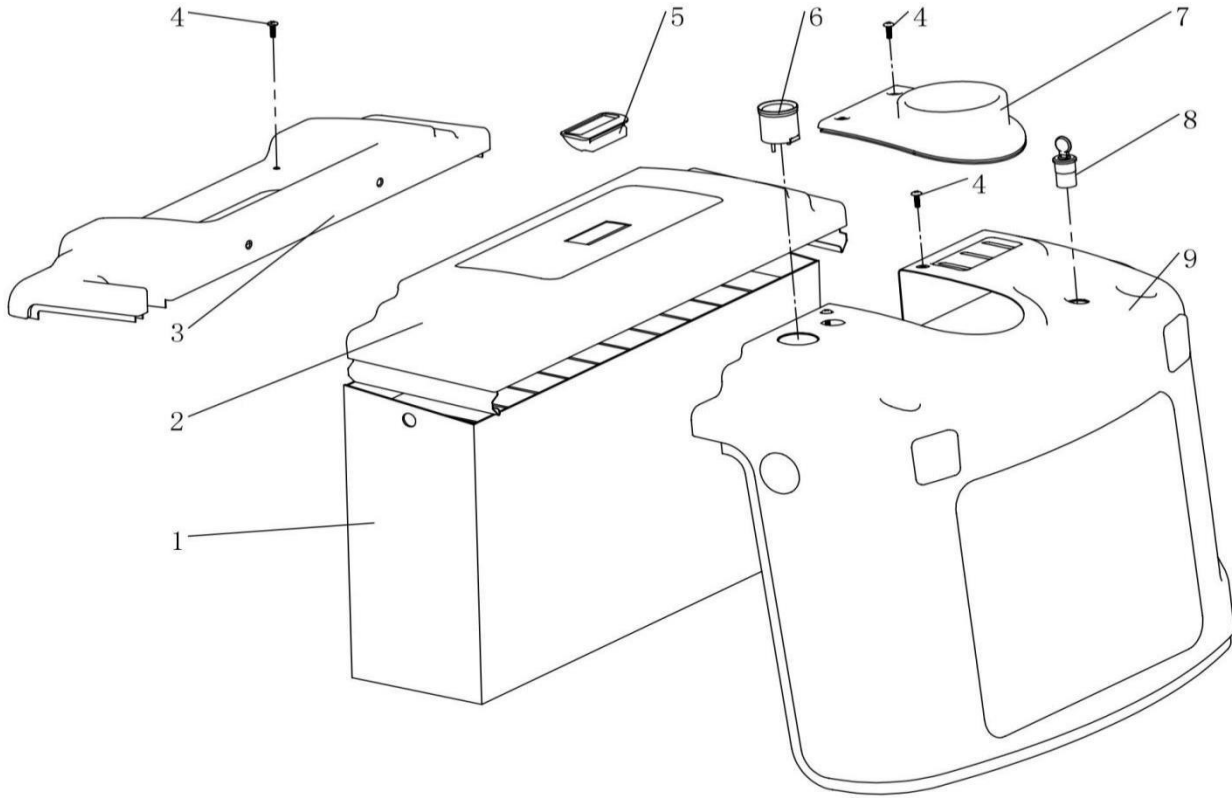

No.	Code No.	Name		Qty.	Note
1	EK13-05.6	Battery Component		1	
2	EK13-05.4	The cover for battery		1	
3	EK13-05.5	Electrical box cover		1	
4	GB 973-1976	Large flat head cross screw.	M0.23×0.63	6	
5	TY-02.8	Recessed aluminum extruded drawer pulls		1	
6	TY-01.16	Coulombmeter	DC24V	1	
7	EK13-05.7	Rubber sleeve		1	
8	TY-01.17	XF125 electric lock		1	
9	EK13-05.1	Cover		1	

1.3 Battery Carriage

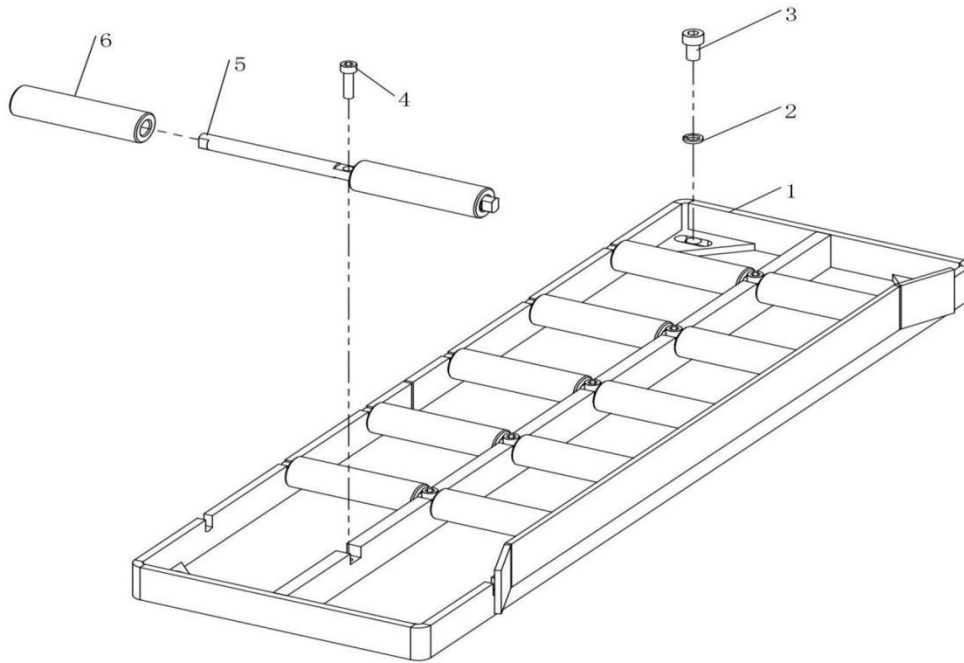

No.	Code No.	Name		Qty.	Note
1	EK13-01.5.1	Pulley frame welded		1	
2	GB/T 93-1987	Spring washer	Φ0.3	4	
3	GB/T 70.1-2000	Hexagon socket head cap screws	M0.3×0.6 3	4	
4	GB/T 70.1-2000	Hexagon socket head cap screws	M0.23×1	6	
5	EK13-01.5.2	Eel shaft		6	
6	EK13-01.5.3	Roller		12	

2. Driving Assembly

2.1 Driving Assembly

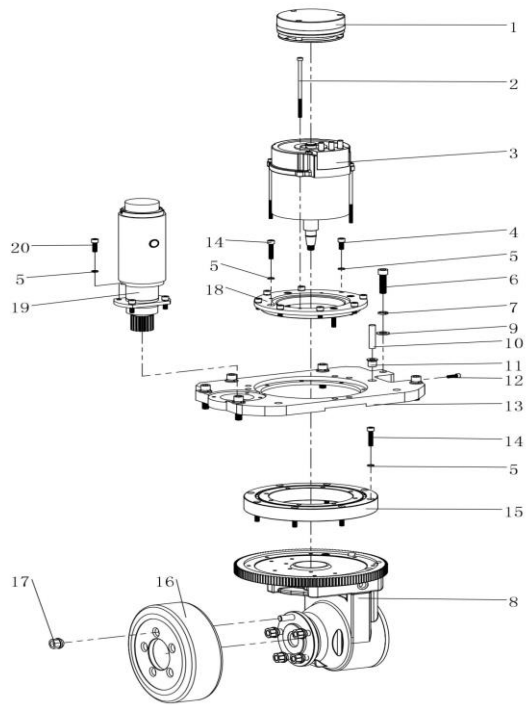

No.	Code No.	Name		Qty.	Note
1	EK13-01.6.3	Electromagnetic brake magnetic sensor assembly.		1	
2	GB/T 70.1-2000	Hexagon socket head cap screws	M0.23×5.9	4	
3	EK13-01.6.7	AC Motor		1	
4	GB/T 70.1-2000	Hexagon socket head cap screws	M0.3×0.8	8	
5	GB/T 93-1987	Spring washer	Φ0.3	24	
6	GB/T 70.1-2000	Hexagon socket head cap screws	M0.5×1.96	6	
7	GB/T 93-1987	Spring washer	Φ0.5	6	
8	ZD-ZV21-500-001	reduction gearbox		1	
9	GB/T 95-2002	Washer	Φ0.5	6	
10	TY-01.40	Proximity switchPM12-04N		1	
11	EK13-01.6.6	Mounting sleeve		1	
12	GB/T 70.1-2000	Hexagon socket head cap screws	M0.23×0.8	1	
13	EK13-01.9.1	Drive backplane (1)		1	
14	GB/T 70.1-2000	Hexagon socket head cap screws	M0.3×1.57	12	
15	EK13-01.6.4	Large slewing bearing		1	
16	ZD-ZV21-BJL-001	Driving big Wheel	Φ9.76	1	
17		Big wheel nut		5	
18	EK13-01.9.2	Drive backplane (2)		1	
19	TY-01.8	Steering wheel	0.2KW	1	
20	GB/T 70.1-2000	Hexagon socket head cap screws	M0.3×1	4	

3.Handle Assembly

3.1 Handle Assembly

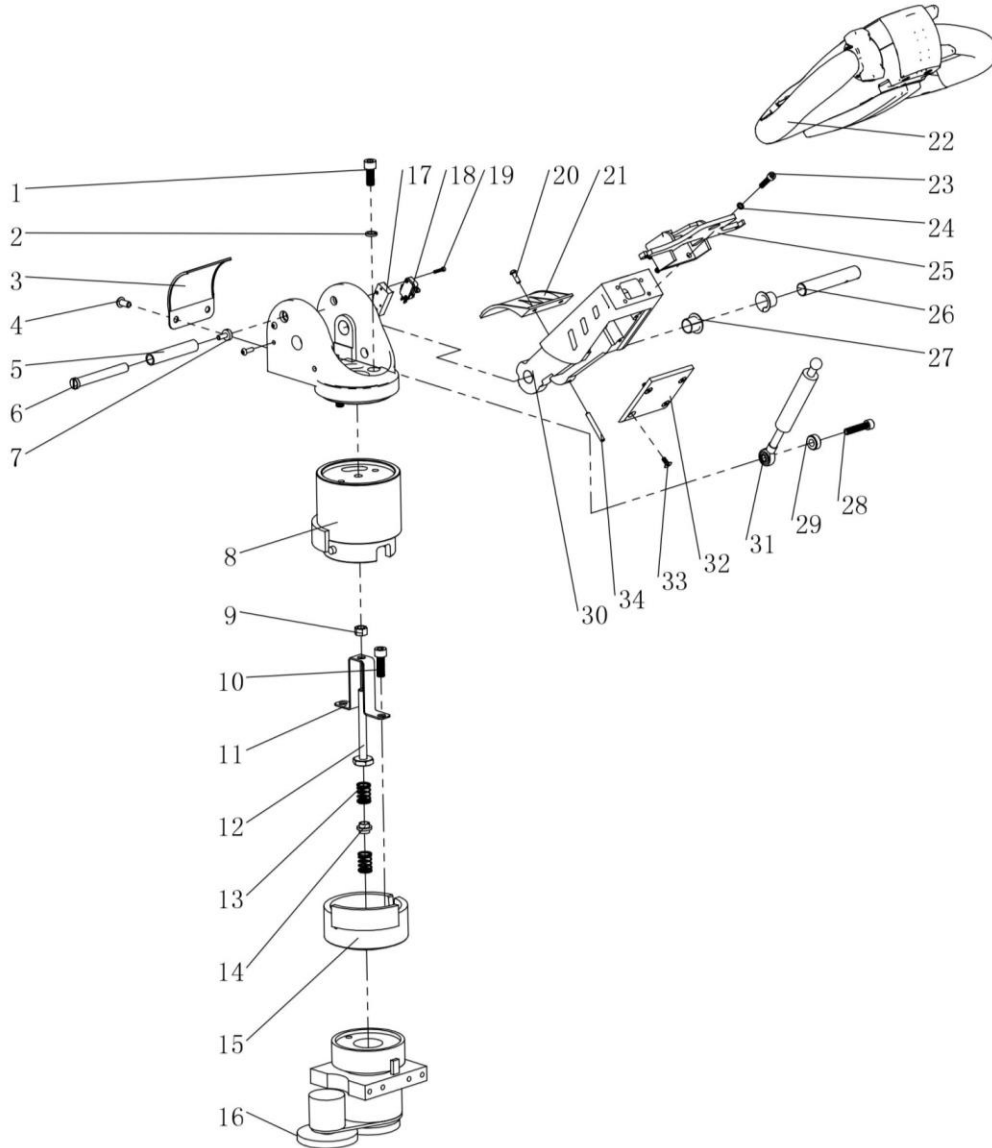

No.	Code No.	Name		Qty.	Note
1	GB/T 70.1-2000	Hexagon socket head cap screws	M0.39×1	2	
2	GB/T 93-1987	Spring washer	Φ0.39	2	
3	EK13-01.10.6	Inner cover		1	
4	GB/T 70.2-2000	Hexagon socket button head screws	M0.3×0.63	2	
5	EK13-01.10.1.4	Silicone tube		1	
6	EK13-01.10.1.2	Pin roll		1	
7	EK13-01.10.1.3	Screw		1	
8	EK13-02.1	Up casing welded		1	
9	GB/T 41-2000	Hexagon nut	M0.39	1	
10	GB/T 70.1-2000	Socket head cap screw	M0.39×1.18	2	
11	EK13-02.2.2	Spring shoe		1	
12	EK13-02.2.4	Adjusting screw		1	
13	EK13.10.3-3	Spring		2	
14	EK13-02.2.3	Spring seat		1	
15	EK13-02.2.1	Lowering casing welded		1	
16	EK13-01.10.3	Rotation direction sensor		1	
17	EK13-01.10.1.7	Mounting plate		1	
18	TY-01.7	MicroswitchRV-166-1C25		1	
19	GB/T 70.1-2000	Socket head cap screw		2	
20	GB/T 70.2-2000	Hexagon socket button head screws	M0.2×0.63	2	
21	EK13-01.10.7	Outer cover		1	
22	TY-01.12	DT Handle T606-1		1	
23	GB/T 70.1-2000	Hexagon socket head cap screws	M0.23×1	4	
24	GB/T 93-1987	Spring washer	Φ0.23	4	
25	EK13-01.10.04	Mounting plate welded		1	
26	EK13-01.10.8	Pin roll		1	
27	TY-02.2	Composite set with shoulder Φ28×Φ20×Φ18×16		2	
28	GB/T 70.1-2000	Hexagon socket head cap screws	M0.3×1.57	1	
29	EK13-01.10.12	Spacer bush		1	
30	EK13-01.10.5	Handle connecting rod		1	
31	EK13-01.10.02	Gas spring component		1	
32	EK13-01.10.11	Cover plate		1	
33	GB/T 70.3-2000	Hexagon socket countersunk head screws	M0.2×0.5	4	
34	GB/T 879.2-2000	Elastic cylindrical pin	Φ0.2×1.77	1	

4.Frame Assembly

4.1 Frame Assembly

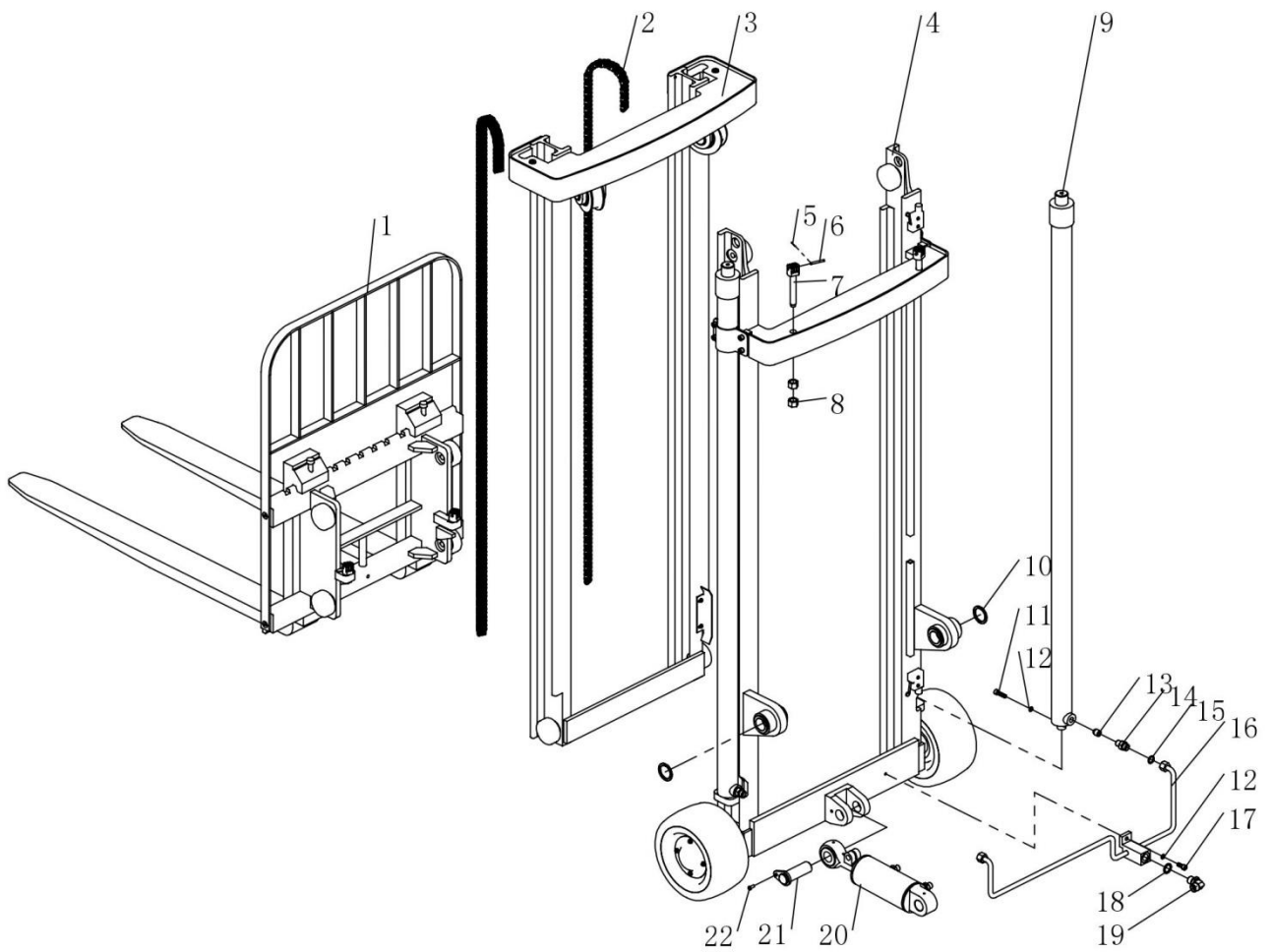

No.	Code No.	Name		Qty.	Note
1	EK13-03.3	Carriage components		1	
2	LH0866	Leaf chain		2	
3	EK13-03.2	Inner frame components		1	
4	EK13-03.1	Outer frame components		1	
5	GB/T 91-2000	Split pin	Φ0.05×0.7	8	
6	GB 880-86	Pins with split pin hole	Φ0.2×1.57	4	
7	CG1646.02-4	Chain bolt		2	
8	GB/T 41-2000	Hexagon nut	M0.63	4	
9	EK13-03.4	Lifting cylinder components		2	
10	EK13-03.7	Sleeve		2	
11	GB/T 70.1-2000	Hexagon socket head cap screws	M0.3×1.18	2	
12	GB/T 93-1987	Spring washer	Φ0.3	4	
13	CL10.4.3	Anti-explosion valve		1	
14	EK13-01.8.7	Straight Adapter		1	
15	GB982-77	Combination gasket	Φ0.63	1	
16	EK13-03.5	Steel tube		1	
17	GB/T 70.1-2000	Hexagon socket head cap cscrews	M0.3×0.8	2	
18	GB892-77	Combination gasket	Φ0.8	1	
19	EK13-03.6	Adjustable Adapter		1	
20	EK13-03.4	Inclined oil cylinder components		1	
21	EK13-01.6	Inclined oil cylinder Pin shaft welded		1	
22	GB/T 70.2-2000	Hexagon socket button head screws	M0.23×0.63	1	

4.2 Outer frame components

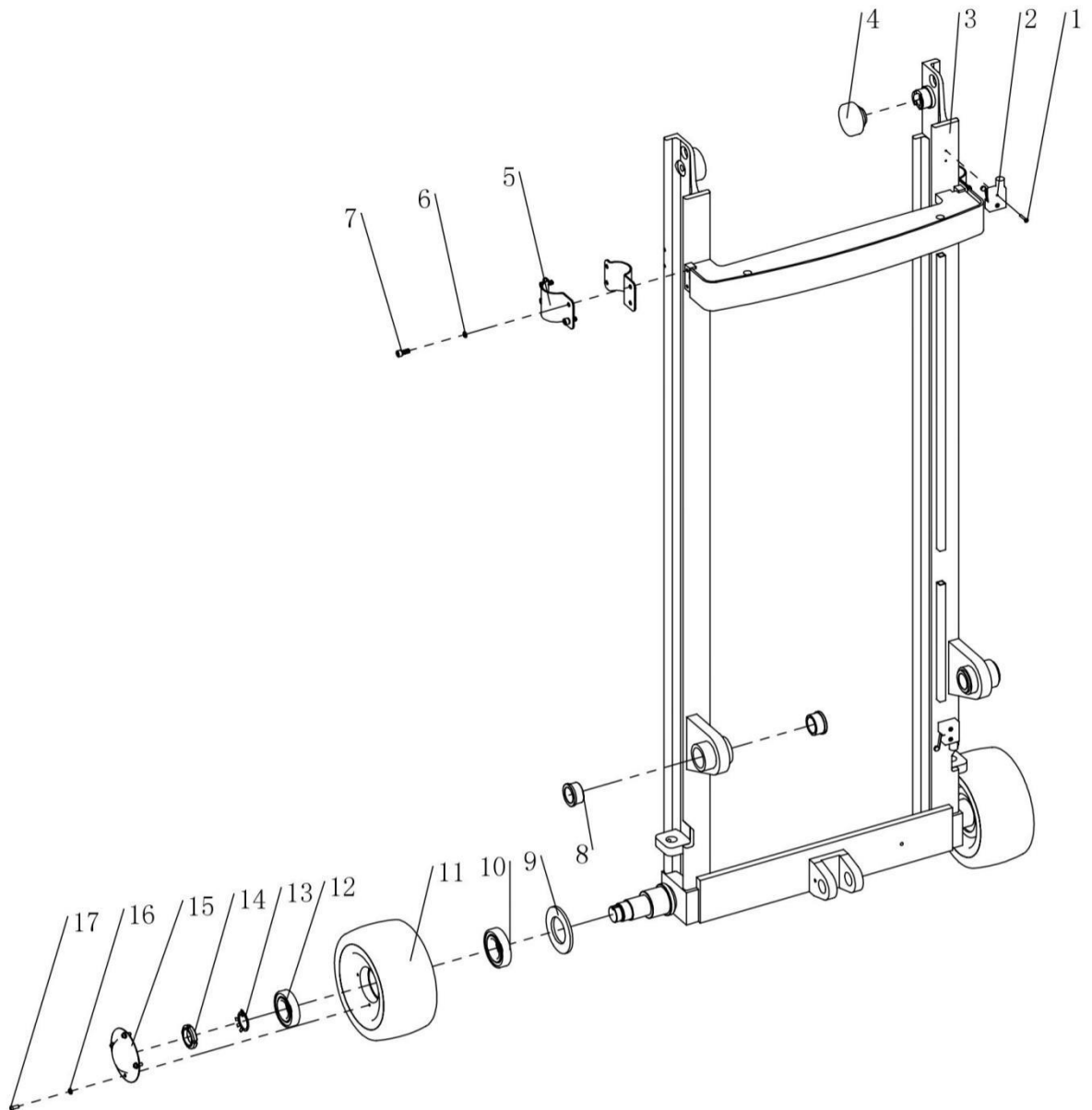

No.	Code No.	Name		Qty.	Note
1	GB/T 818-2000	Cross recessed pan head screw	M0.16×1	4	
2	TY-01.35	MicroswitchRZ-15GW2S-B3		2	
3	EK13-03.1.1	Outer frame welded		1	
4	CRA70.4-4S	Composite roller		2	
5	EK13-03.1.4	Oil cylinder hoop		4	
6	GB/T 93-1987	Spring washer	Φ0.3	8	
7	GB/T 70.1-2000	Hexagon socket head cap screws	M0.3×0.8	8	
8	EK13-03.10	Connect copper sleeve		4	
9	EK13-03.1.3.1	Felt seal ring		2	
10	GB/T 276-94	Deep groove ball bearing	6209-2Z	2	
11	TY-02.56	The front wheel		2	
12	GB/T 276-94	Deep groove ball bearing	6208-2Z	2	
13	GB 858-1988	lock washer for round nut	Φ1.37	2	
14	GB/T 812-1988	Round nut	M0.37×0.06	2	
15	EK13-03.1.5	The end cover for front wheel		2	
16	GB/T 95-2002	Flat washer	Φ0.23	8	
17	GB/T 70.2-2000	Hexagon socket button head screws	M0.23×0.63	8	

4.3 Inner Frame Components

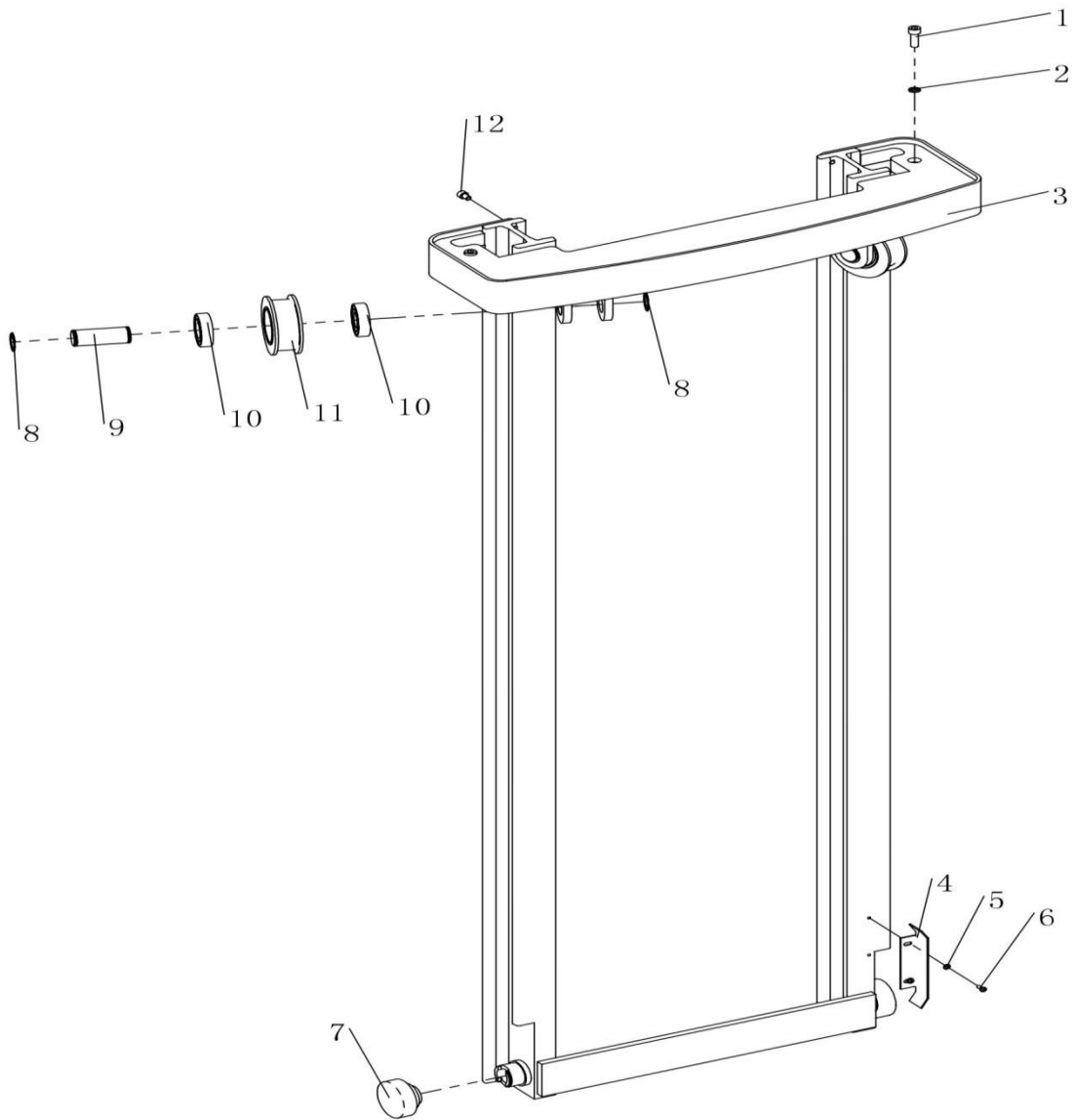

No.	Code No.	Name		Qty.	Note
1	GB/T 70.1-2000	Hexagon socket head cap screws	M0.39×1.18	2	
2	GB/T 93-1987	Spring washer	Φ0.39	2	
3	EK13-03.2.1	Inner frame welded		1	
4	EK13-03.2.2	Stop plate		1	
5	GB/T 95-2002	Flat washer	Φ0.2	2	
6	GB/T 818-2000	Cross recessed pan head screw	M0.2×0.5	2	
7	CRA70.4-4S	Composite roller		2	
8	GB 894.1-86	Circlip for shaft	Φ1.18	4	
9	CG1646.03.3-6	Chain wheel axle		2	
10	GB/T 276-94	Deep groove ball bearing	6206-2Z	4	
11	EK13.03.3-5	Chain wheel A		2	
12	GB/T 70.1-2000	Hexagon socket head cap screws	M0.3×0.5	2	

4.4 Carriage components

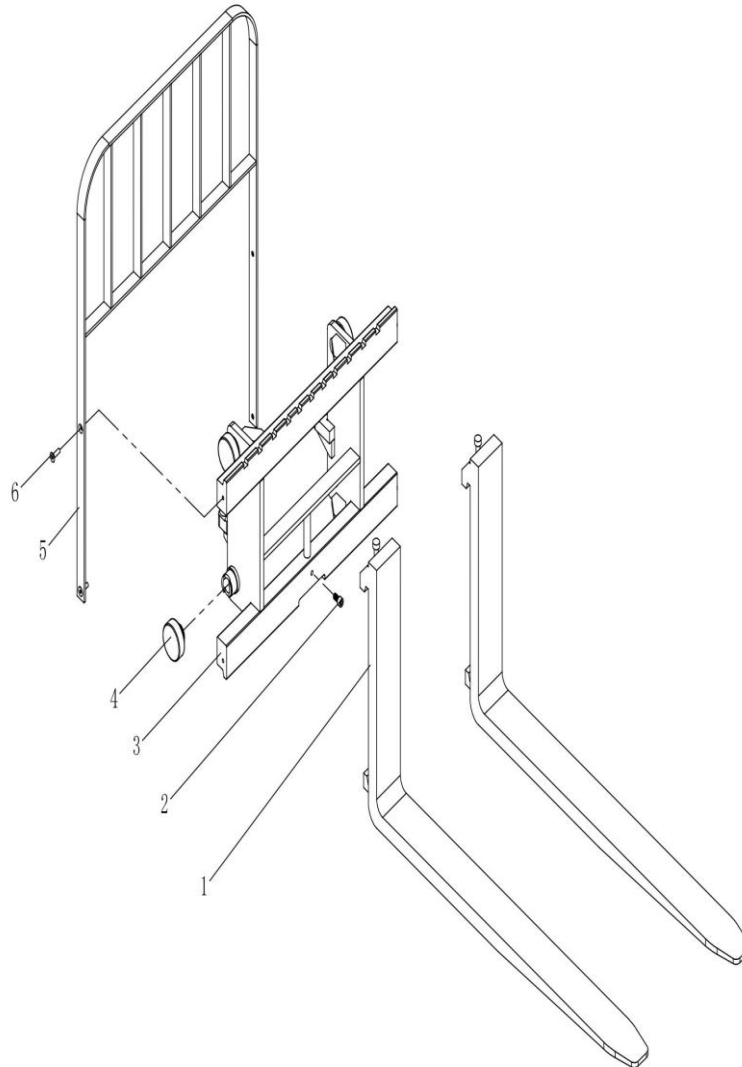

No.	Code No.	Name		Qty.	Note
1	EK13-03.3.3	Forks		2	
2	GB/T 70.1-2000	Hexagon socket head cap screws	M0.39×0.8	1	
3	EK13-03.3.1	Carriage welded		1	
4	CRA70.4-4S	Composite roller		4	
5	EK13-03.3.2	Parapet wall welded		1	
6	GB/T 70.3-2000	Hexagon socket countersunk head screws	M0.3×1.18	4	

4.5 Frame Assembly(Three Mast of Full free)

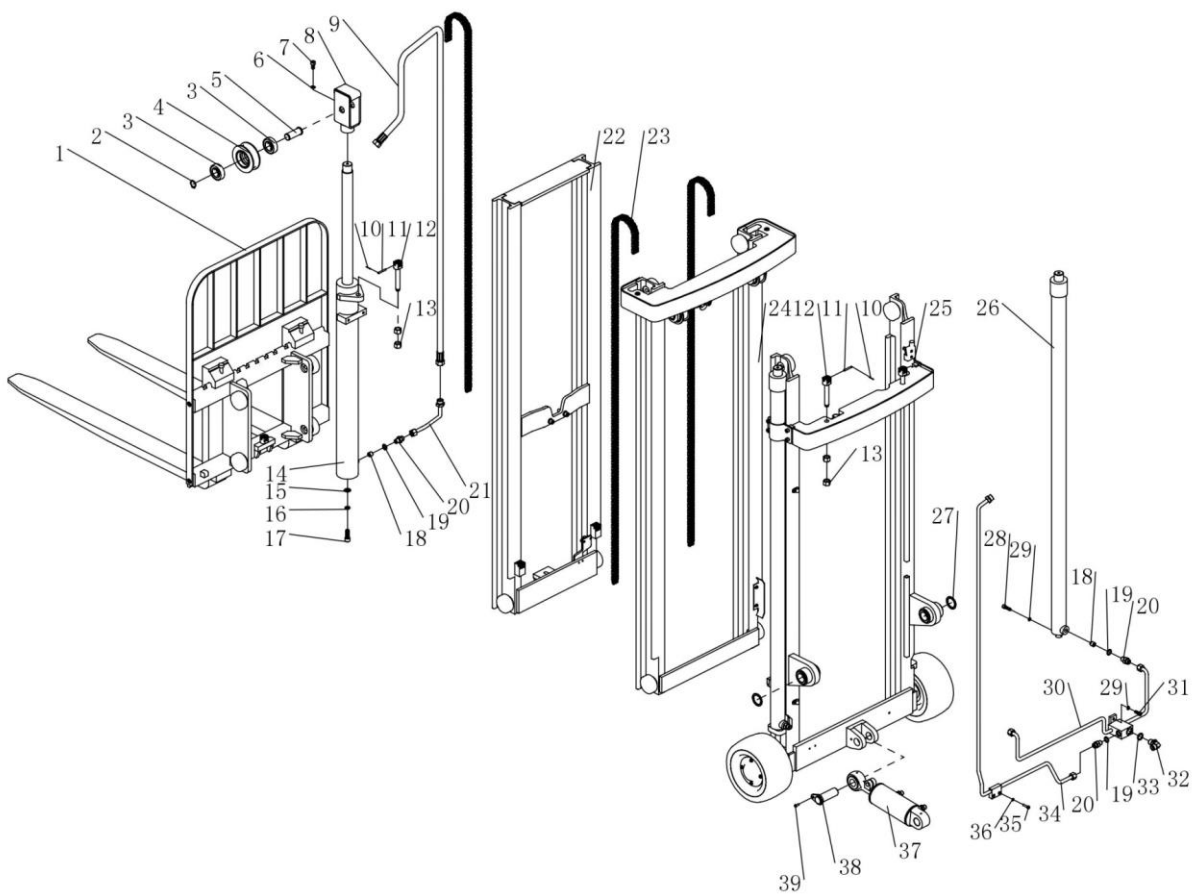

No.	Code No.	Name		Qty.	Note
1	EK13-06.4	Carriage components		1	
2	GB 894.1-86	Circlip for shaft	Φ1	1	
3	GB/T 276-94	Deep groove ball bearing	6305-2Z	2	
4	EK136.03.3-5	Chain wheel A		1	
5	EK13.02-09	Chain wheel axle		1	
6	GB/T 93-1987	Spring washer	Φ0.39	1	
7	GB/T 70.1-2000	Hexagon socket head cap screws	M0.39×0.8	1	
8	EK13QD.02.07	Chain wheel rack welded		1	
9	EK13-06.10	High pressure rubber hose		1	
10	GB/T 91-2000	Split pin	Φ0.05×0.7	2	
11	GB 880-86	Pins with split pin hole	Φ0.2×1.57	3	
12	EK131646.02-4	Chain bolt		3	
13	GB/T 41-2000	Hexagon nut	M0.63	6	
14	EK13-06.5	Lifting cylinder components in front		1	
15	GB/T 95-2002	Flat washer	Φ0.5	1	
16	GB/T 93-1987	Spring washer	Φ0.5	1	
17	GB/T 70.1-2000	Hexagon socket head cap screws	M0.5×1.37	1	
18	EK13.4.3	Explosion-proof valve core		3	
19	GB982-77	Combination gasket	Φ0.63	4	
20	EK13-01.8.7	Straight Adapter		4	
21	EK13-06.8	Steel tube (2)		1	
22	EK13-06.3	Inner frame components		1	
23	LH0866	Leaf chain		3	
24	EK13-06.2	Middle frame components		1	
25	EK13-03.1	Outer frame components		1	
26	EK13-06.6	Lifting cylinder components in rear		2	
27	EK13-03.7	Sleeve		2	
28	GB/T 70.1-2000	Hexagon socket head cap screws	M0.3×1.18	2	
29	GB/T 93-1987	Spring washer	Φ0.3	3	
30	EK13-06.7	Steel tube (1)		1	
31	GB/T 70.1-2000	Hexagon socket head cap screws	M0.3×0.8	1	
32	EK13-01.7.1	Adjustable Adapter		1	
33	GB892-77	Combination gasket	Φ0.8	1	
34	EK13-06.9	Steel tube (3)		1	
35	GB/T 70.1-2000	Hexagon socket head cap screws	M0.23×1	2	
36	GB/T 93-1987	Spring washer	Φ0.23	2	
37	EK13-03.4	Inclined oil cylinder components		1	
38	EK13-01.6	Inclined oil cylinder Pin shaft welded		1	
39	GB/T 70.2-2000	Hexagon socket button head screws	M0.23×0.63	1	

4.6 Outer Frame Assembly(Three Mast of Full free)

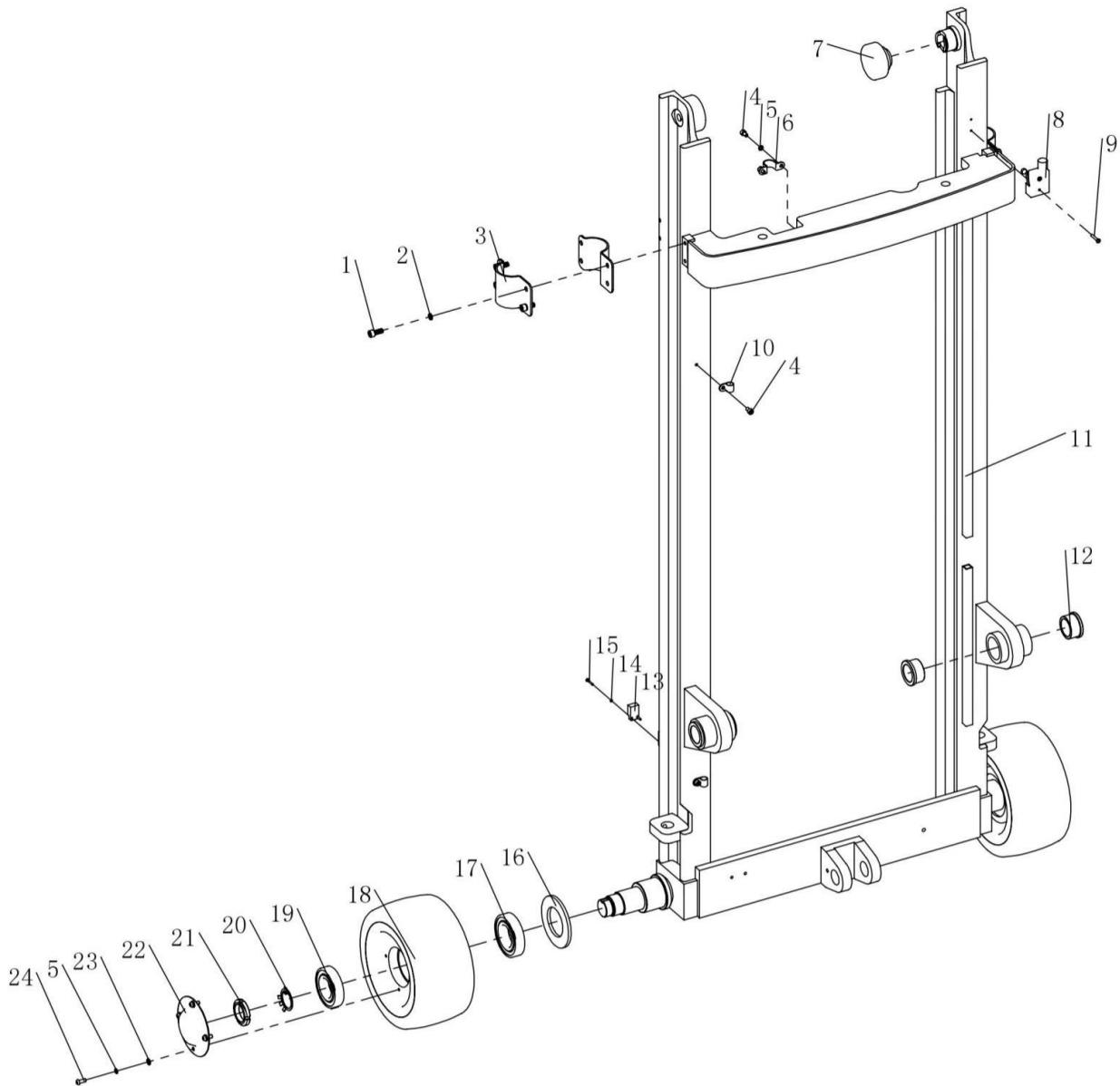

No.	Code No.	Name		Qty.	Note
1	GB/T 70.1-2000	Hexagon socket head cap screws	M0.3×0.8	8	
2	GB/T 93-1987	Spring washer	Φ0.3	8	
3	EK13-03.1.4	Oil cylinder hoop		4	
4	GB/T 70.1-2000	Hexagon socket head cap screws	M0.23×0.39	4	
5	GB/T 93-1987	Spring washer	Φ0.23	10	
6		Hoop	Φ0.82	1	
7	CRA70.4-4S	Composite roller		2	
8	TY-01.35	MicroswitchRZ-15GW2S-B3		1	
9	GB/T 818-2000	Cross recessed pan head screw	M0.16×1	2	
10		R hoop	Φ0.5	2	
11	EK13-06.1.1	Outer frame components		1	
12	EK13-03.10	Connect copper sleeve		4	
13	TY-01.38	Proximity switchCLJF20-05FA		1	
14	GB/T 93-1987	Spring washer	Φ0.11	2	
15	GB/T 818-2000	Cross recessed pan head screw	M0.11×0.8	2	
16	EK13-03.1.3.1	Felt seal ring		2	
17	GB/T 276-94	Deep groove ball bearing	6209-2Z	2	
18	TY-02.56	Front wheel		2	
19	GB/T 276-94	Deep groove ball bearing	6208-2Z	2	
20	GB 858-1988	Lock washer for round nut	Φ1.37	2	
21	GB/T 812-1988	Round nut	M1.37×0.06	2	
22	EK13-03.1.5	End cover for front wheel		2	
23	GB/T 95-2002	Flat washer	Φ0.23	8	
24	GB/T 70.2-2000	Hexagon socket button head screws	M0.23×0.63	8	

4.7 Middle Frame Assembly(Three Mast of Full free)

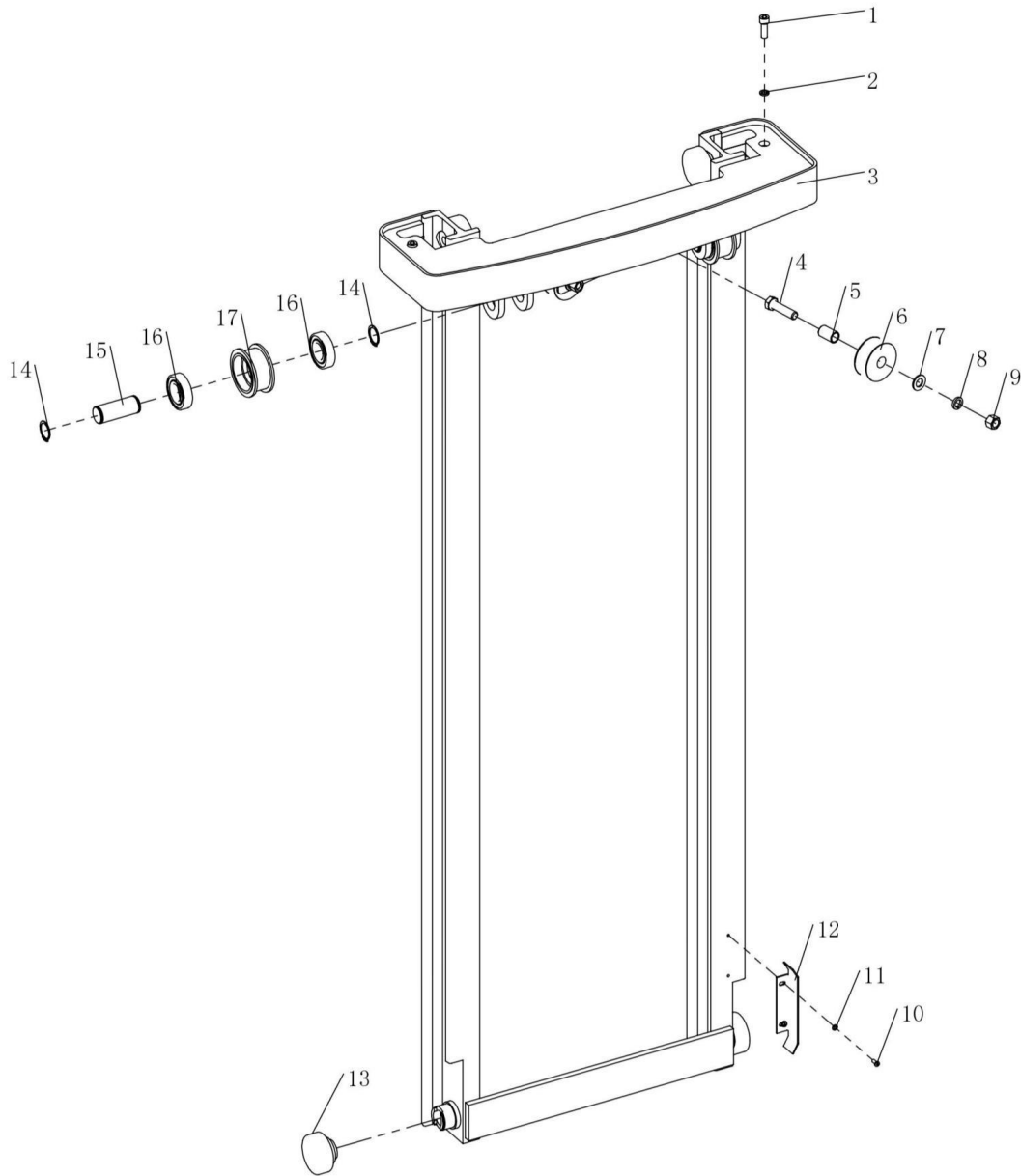

No.	Code No.	Name		Qty.	Note
1	GB/T 70.1-2000	Hexagon socket head cap screws	M0.39×1.18	2	
2	GB/T 93-1987	Spring washer	Φ0.39	2	
3	EK13-06.2.1	Middle frame welded		1	
4	GB/T 5781-2000	Hexagon bolt	M0.55×2.16	2	
5	EK13-07.2.3	Carriage sleeve		2	
6	EK13-07.2.2	Carriage		2	
7	GB/T 95-2002	Flat washer	Φ0.55	2	
8	GB/T 93-1987	Spring washer	Φ0.55	2	
9	GB/T 41-2000	Hexagon nut	M0.55	2	
10	GB/T 818-2000	Cross recessed pan head screw	M0.2×0.5	2	
11	GB/T 95-2002	Flat washer	Φ0.2	2	
12	EK13-03.2.2	Stop plate		1	
13	CRA70.4-4S	Composite roller		4	
14	GB 894.1-86	Circlip for shaft	Φ1.18	4	
15	EK131646.03.3-6	Chain wheel axle		2	
16	GB/T 276-94	Deep groove ball bearing	6206-2Z	4	
17	EK131646.03.2-7	Chain wheel B		2	

4.8 Inner Frame Assembly(Three Mast of Full free)

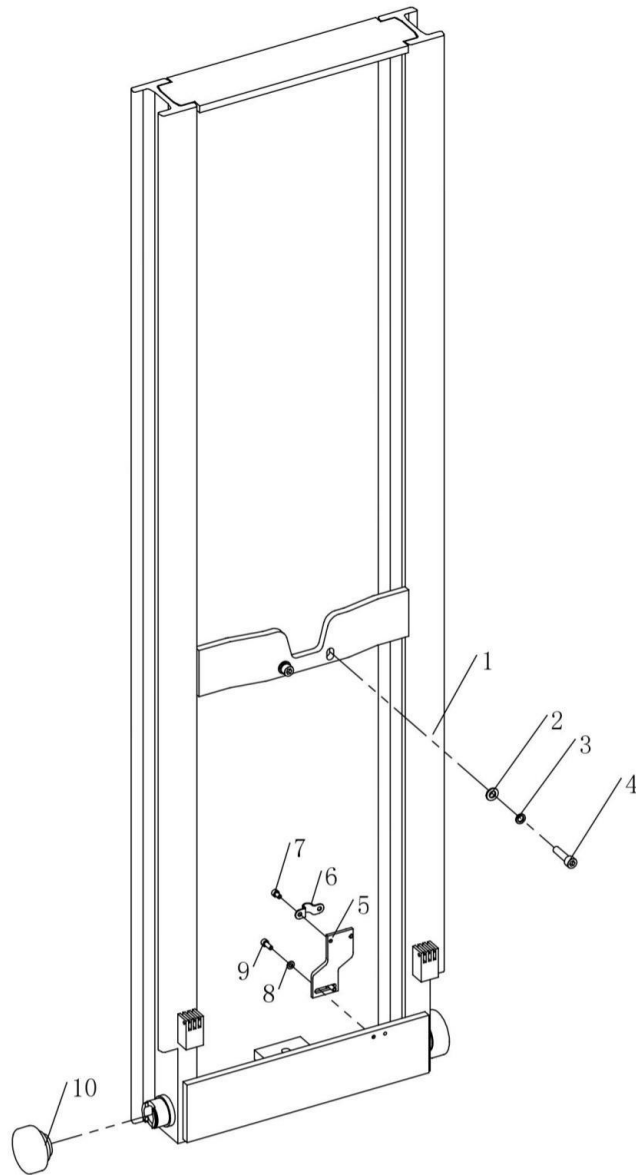

No.	Code No.	Name		Qty.	Note
1	EK13-06.3.1	Inner Frame welded		1	
2	GB/T 95-2002	Flat washer	Φ0.39	2	
3	GB/T 93-1987	Spring washer	Φ0.39	2	
4	GB/T 70.1-2000	Hexagon socket head cap screws	M0.39×1.57	2	
5	EK13QD.02.03.01-1	Tubing fixing plate		1	
6		Hoop	Φ0.5	1	
7	GB/T 70.1-2000	Hexagon socket head cap screws	M0.23×0.39	2	
8	GB/T 95-2002	Flat washer	Φ0.23	2	
9	GB/T 70.1-2000	Hexagon socket head cap screws	M0.23×0.63	2	
10	CRA70.4-4S	Composite roller		2	

4.9 Carriage Components(Three Mast of Full free)

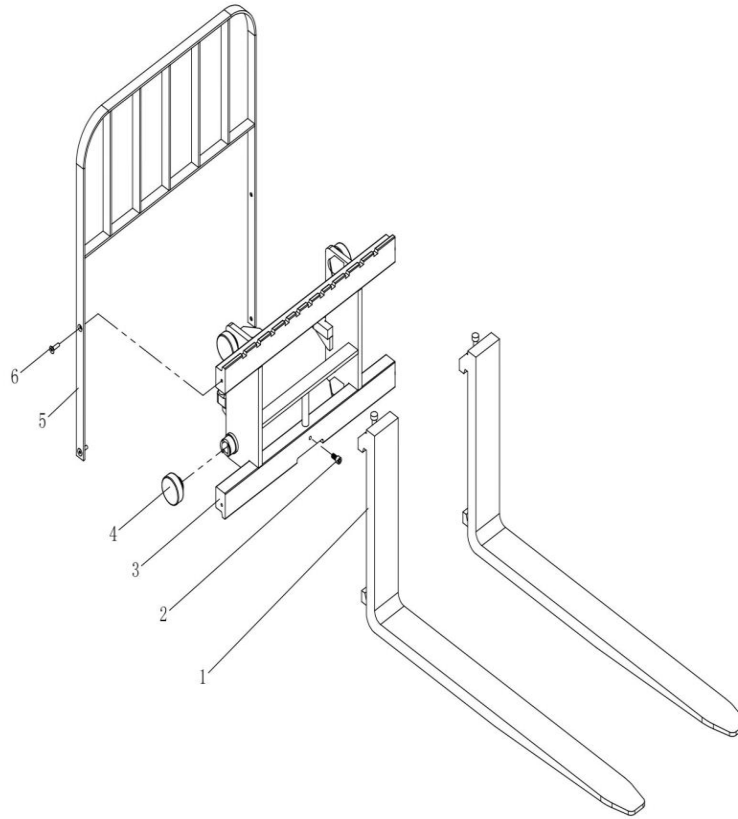

No.	Code No.	Name		Qty.	Note
1	EK13-03.3.3	Forks		2	
2	GB/T 70.1-2000	Hexagon socket head cap screws	M0.39×0.8	1	
3	EK13-06.4.1	Carriage welded		1	
4	CRA70.4-4S	Composite roller		4	
5	EK13-03.3.2	Parapet wall welded		1	
6	GB/T 70.3-2000	Hexagon socket countersunk head screws	M0.3×1.18	4	

5. Hydraulic System

5.1 Hydraulic System

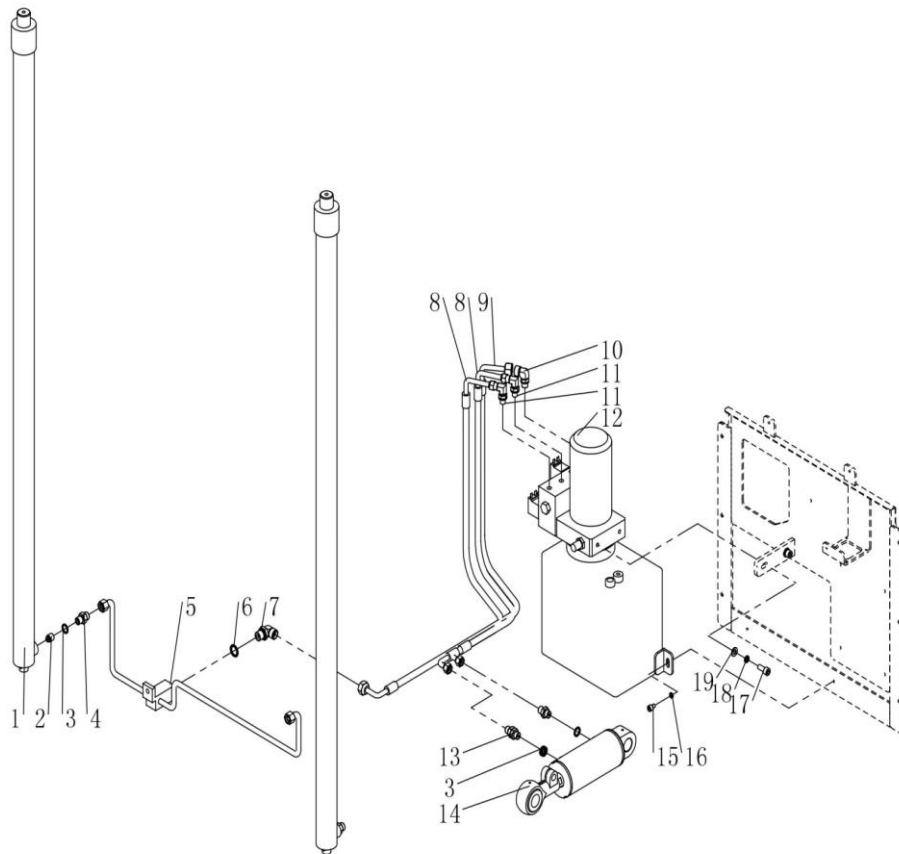

No.	Code No.	Name		Qty.	Note
1	EK13-03.4	Lifting oil cylinder components		2	
2	EK13.4.3	Explosion-proof valve core		1	
3	GB982-77	Combination gasket	Φ0.63	4	
4	EK13-01.8.7	Straight Adapter		2	
5	EK13-03.5	Steel tube		1	
6	GB892-77	Combination gasket	Φ0.8	1	
7	EK13-03.6	Adjustable Adapter		1	
8	EK13-01.6.5	Tilt hose		2	
9	EK13-01.6.4	Lifting hose		1	
10	EK13-01.7.1	Adjustable Adapter		1	
11	EK13-01.6.3	Adjustable Adapter		2	
12	EK13-01.6.2	Power unit		1	
13	EK13.05.1-4	Straight Adapter		2	
14	EK13-03.4	Inclined oil cylinder components		1	
15	GB/T 70.1-2000	Hexagon socket head cap screws	M0.3×0.5	2	
16	GB/T 93-1987	Spring washer	Φ0.3	2	
17	GB/T 70.1-2000	Hexagon socket head cap screws	M0.39×1	2	
18	GB/T 93-1987	Spring washer	Φ0.39	2	
19	GB/T 95-2002	Flat washer	Φ0.39	2	

6. Electrical Assembly

6.1 Electrical Assembly

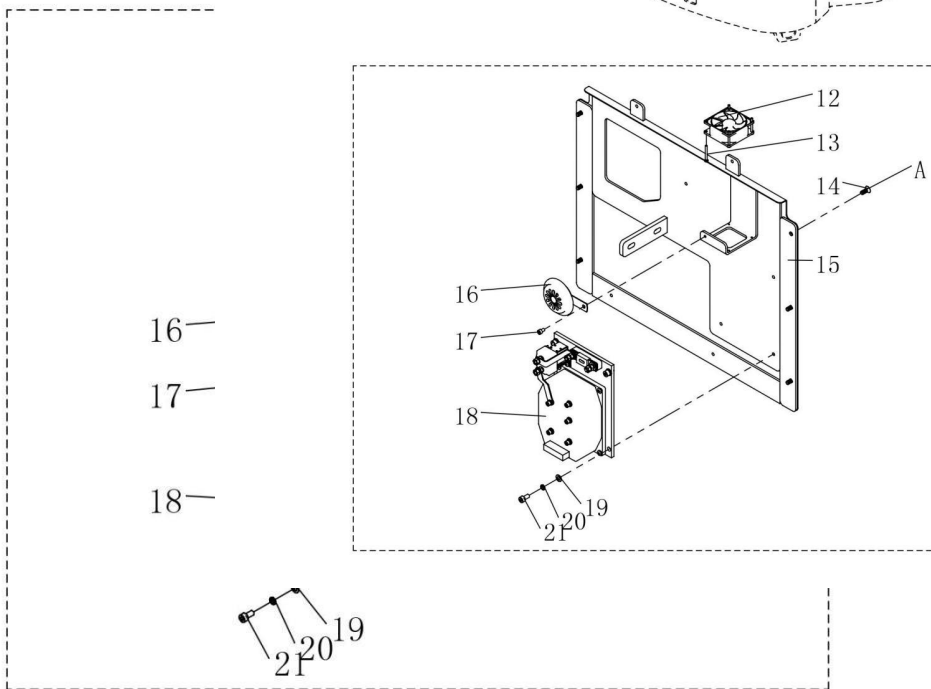
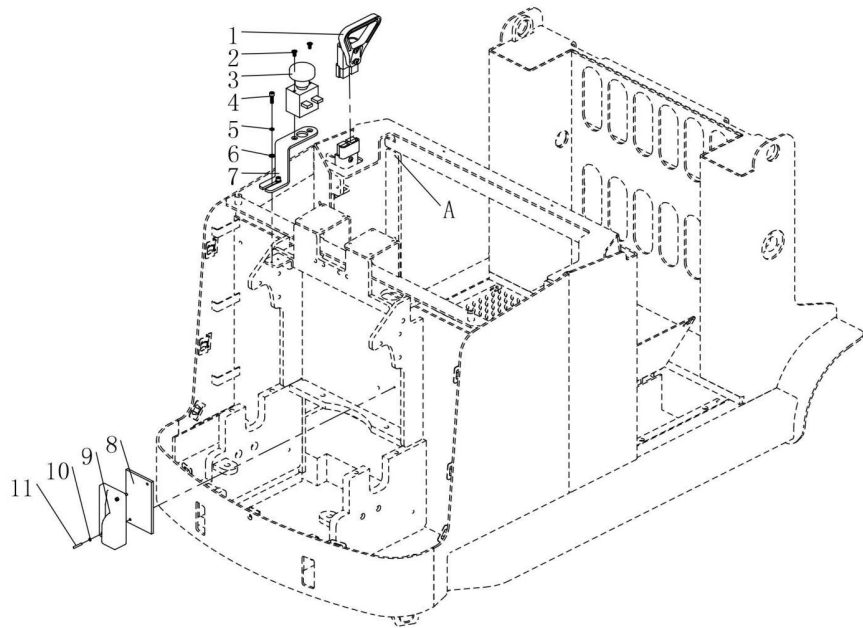
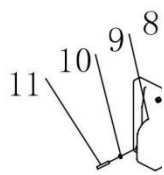
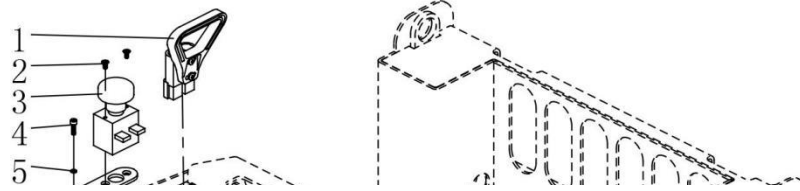

No.	Code No.	Name		Qty.	Note
1	TY-02.57	Large power supply connector components		1	
2	GB 2673-86	Hexagon socket countersunk head screws	M0.23×0.5	2	
3	TY-01.14	Emergency stop switch ZDK31-250		1	
4	GB/T 70.1-2000	Hexagon socket head cap screws	M0.23×0.8	2	
5	GB/T 93-1987	Spring washer	Φ0.23	2	
6	GB/T 95-2002	Flat washer	Φ0.23	2	
7	EK13-01.15	Power switch mounting bracket		1	
8	DK1220-01.1	Electrically controlled mounting plate		1	
9	TY-01.49	Steering electric controller 1212P-2502		1	
10	GB/T 859-1987	Spring washer	Φ0.16	2	
11	GB/T 70.1-2000	Hexagon socket head cap screws	M0.16×1.18	2	
12	TY-01.28	Fan	3.15×3.15	1	
13	GB/T 818-2000	Cross recessed pan head screw	M0.16×1.57	4	
14	GB 2673-86	Hexagon socket countersunk head screws	M0.3×0.8	6	
15	EK13-01.6.1	Neutral plate welded		1	
16	TY-01.18	Horn DC24-Φ125		1	
17	GB/T 70.1-2000	Hexagon socket head cap screws	M0.23×0.39	1	
18	DK1232-01	AC Electric control components		1	
19	GB/T 95-2002	Flat washer	Φ0.3	4	
20	GB/T 93-1987	Spring washer	Φ0.3	4	
21	GB/T 70.1-2000	Hexagon socket head cap screws	M0.3×0.63	4	

6.2 DK1232-01 AC Electronic control components.

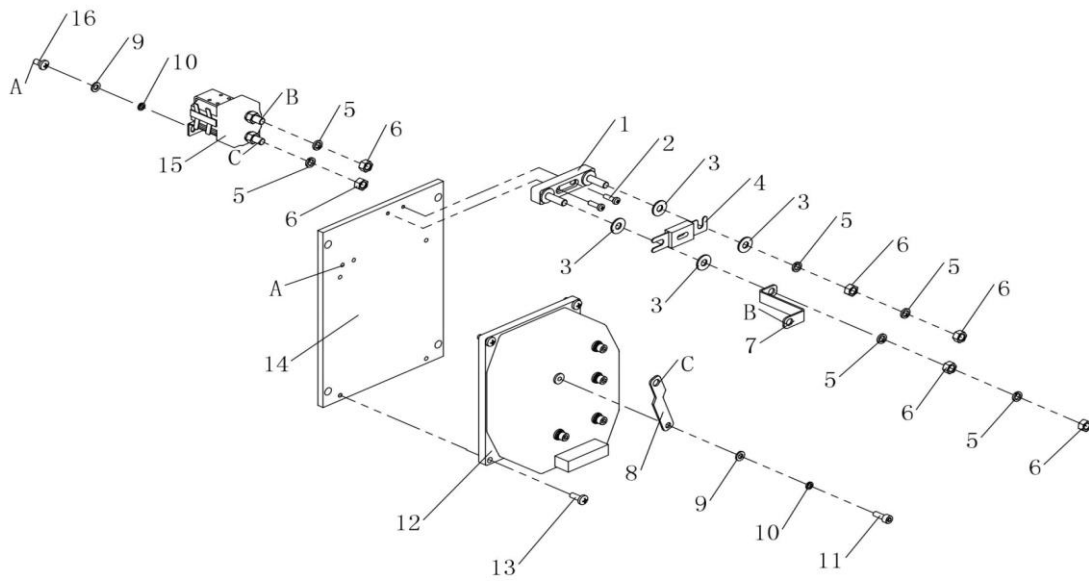

No.	Code No.	Name		Qty.	Note
1	TY-02.32	Fuse base		1	
2	GB/T 818-2000	Cross recessed pan head screw	M0.2×0.63	2	
3		Copper gasket		4	
4	TY-01.1	Fuse	200A	1	
5	GB/T 93-1987	Spring washer	Φ0.3	6	
6	GB/T 6170-2000	Hexagon nut	M0.3	6	
7	DK1230-01.2	Copper sheet (1)		1	
8	DK1232-01.2	Copper sheet (3)		1	
9	GB/T 95-2002	Flat washer	Φ0.23	7	
10	GB/T 93-1987	Spring washer	Φ0.23	7	
11	GB/T 70.1-2000	Hexagon socket head cap screws	M0.23×0.63	5	
12	1232E	AC electric controller		1	
13	GB/T 818-2000	Cross recessed pan head screw	M0.23×0.63	4	
14	DK1232-02.1	Electric controller mounting plate		1	
15	TY-01.41	Relay	SW80	1	
16	GB/T 818-2000	Cross recessed pan head screw	M0.23×0.5	2	

The power of interpretation of this part catalogue will be preserved by the manufacturer.