

- 3000 lbs. load capacity
- Lift height 118-138"
- Lowered Mast Height 85-94.2"
- Polyurethane Tires
- Batteries 24V/85Ah
- Charger Included
- DC Drive Motor
- USB charging port

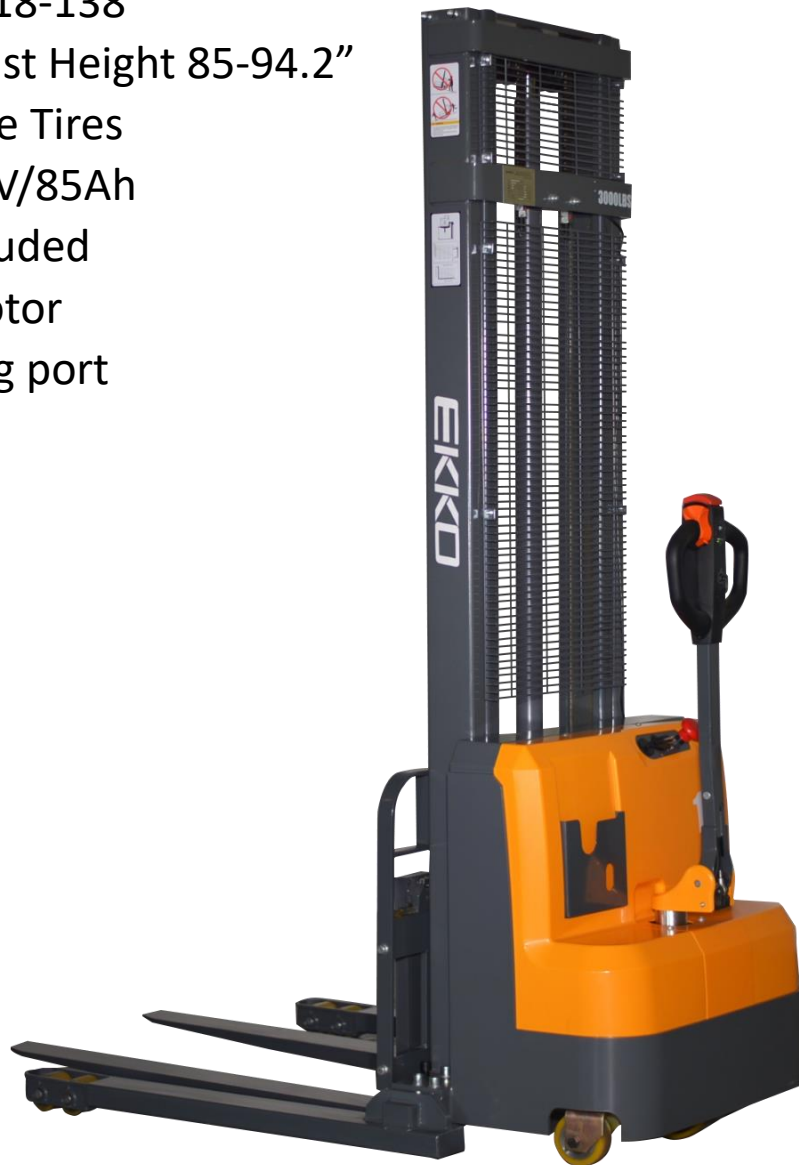

# Straddle Stacker

EB14C-118 / EB14C-138



Model	EB14C-118/138	
Power Type	Electric	
Operating Mode	Walk-behind	
Rated Load Capacity	Q (lb.)	3000
Load Center Distance	c (in)	20
Wheelbase	y (in)	50.2
Tire Type, Drive Wheel/Load Wheel	Polyurethane Tires	
Drive Wheel Size (Diameter × Width)	in	Φ8.2x2.8
Load Wheel Size (Diameter × Width)	in	Φ3.1x2.8
Number of Vehicles, x = Drive Wheel	1X+2/4	
Height When Mast is Retracted	h1 (in)	85.0 / 94.2
Lift Height	h3 (in)	118 / 138
Maximum Height When Mast is Extended	h4 (in)	146.5 / 166.9
Minimum Fork Height	h13 (in)	2.6
Overall Length	l1 (in)	71.3
Inner Width of Legs	in	35.4 / 39.4 / 43.3 / 47.2 / 51.2
Fork Dimensions	s/e/l	1.4 × 4.0 × 45.3
Fork Adjustment Range (Fork Outer Width)	b5 (in)	8.7 – 32.1
Minimum Ground Clearance at Wheelbase Center	m2(in)	1.2
Minimum Turning Radius	Wa(in)	57.5
Travel Speed, Laden/Unladen	mph	2.5/2.5
Lift Speed, Laden/Unladen	in/s	3.7/5.1
Climbing Speed, Laden/Unladen	%	5/10
Service Brake	Electromagnetic	
Drive Motor Power	kw	0.75
Lift Motor Power	kw	2.2
Battery Voltage/Rated Capacity	(V)/(Ah)	Lead-acid Battery 24/85
Charger Voltage	(V)/(A)	Lead-acid Battery 24/10
Type of Drive Control	DC	
Steering Type	Mechanical	

# Straddle Stacker

EB14C-118 / EB14C-138

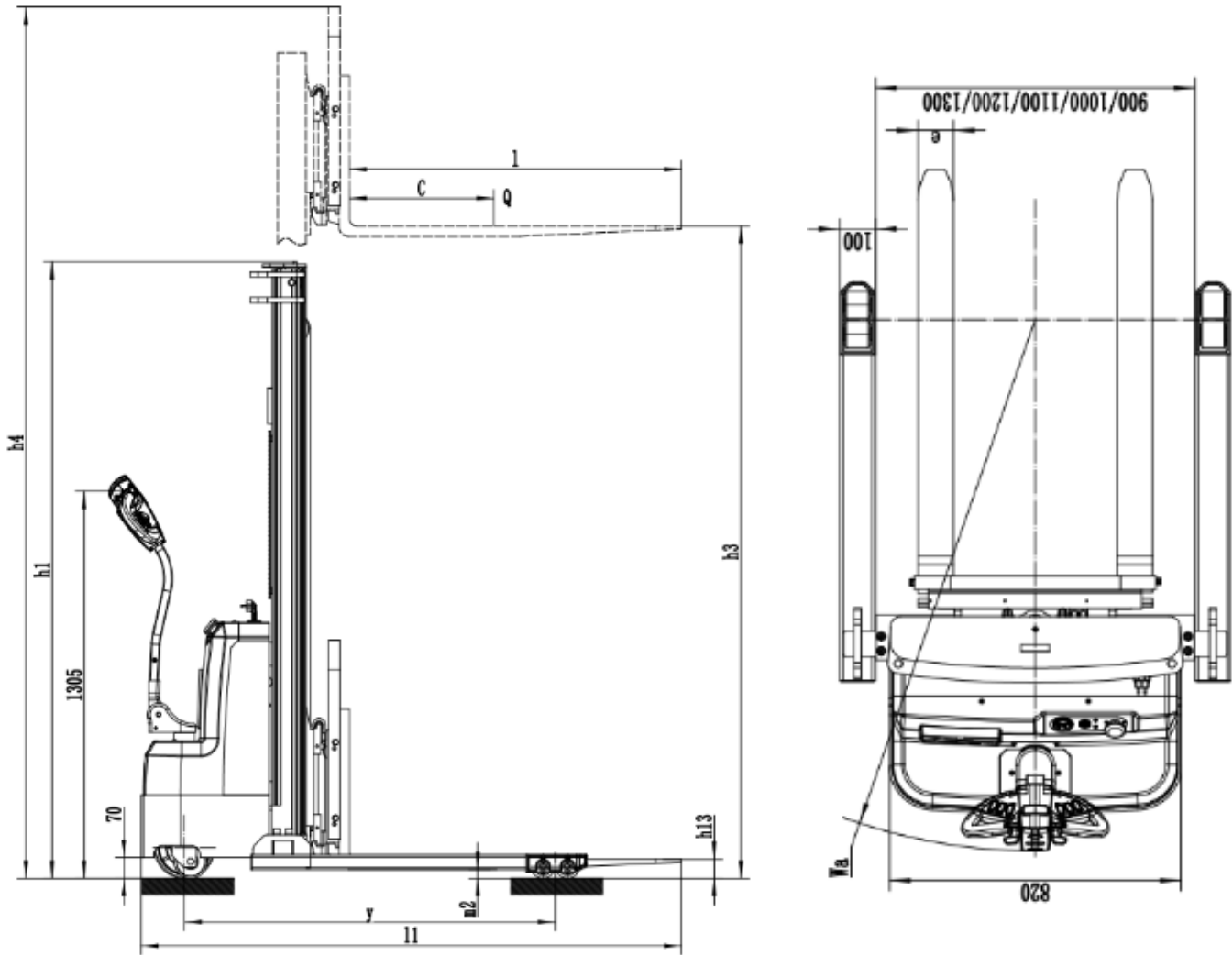

MODEL #	MAST	LIFT HEIGHT	MAX MAST HEIGHT	SERVICE WEIGHT
EB14C-118	85"	118"	146.5"	1520 Lbs.
EB14C-138	94.2"	138"	166.9"	1780 Lbs.



1761 W. Holt Ave.

Pomona, CA 91768 USA

AUTHORIZED DEALERS ONLY

[www.ekkolifts.com](http://www.ekkolifts.com)

T: (877) 232-6517 F: (909) 222-6861