

EKKO[®]

MATERIAL HANDLING EQUIPMENT

**MOVING
AHEAD**

CATALOG



WWW.EKKOLIFTS.COM

Table of Contents

Description	Page
About Us	1
Diesel Forklifts	2
LPG Forklifts	7
Electric Forklifts – Lead acid	20
Electric Forklifts – Lithium	27
Reach Trucks	
Order Picker	
Counterbalance Stackers	
Straddle Stacker	
Pallet Jacks	
Tow Tractor	
Scissor Lift	
Table Lift	



WWW.EKKOLIFTS.COM

About Us

Since 2008, EKKO Material Handling Equipment Manufacturing Inc. has become the go to manufacturer for the OEM and ODM channel. Due to our experience, innovative manufacturing capabilities, design, and our collaborations internationally, we have created enormous success with our partners in supplying them with nothing but quality forklifts, pallet trucks, walkie pallet trucks, walkie rider pallet trucks, stackers, walkie stackers, reachtrucks, and other material handling equipment.

With our strict research and development, quality control, and quality assurance departments, every product has and will continue to pass CE certification with international safety standards and ISO9001 Certification. In addition, our products have acquired self-managed import and export rights throughout North and South America, Europe, Australia and Asia.

OEM and ODM channels are welcomed. Furthermore, non-standard equipment is capable for production according to the customer's specifications and requirements. EKKO insists on the operating theory of "Services Create Enterprise Value", offering you top-ranking quality and professional after-service.

- **Superior Quality**
- **Reliability**
- **Versatility**
- **Advanced Engineering**
- **Competitive Pricing**
- **ISO Certified**
- **CE Certified**
- **Superior Support**
- **3 Years Warranty**



EK20D Diesel Forklift

Model		EK20D
Lift		Diesel
Drive		Sit-Down
Load capacity	(lb.)	4000
Load center distance	(in)	24
Wheelbase	(in)	62.9
Lifting height	(in)	185
Free lifting height	(in)	43.7
Lowered mast height	(in)	83
Mast/Fork carriage tilt forward/backward	(°)	3/6
Side Shift		Cascade
Overall length	(in)	141.8
Overall width	(in)	45.2
Tire Material	(in)	Solid Pneumatic Tire
Fork Size	(in)	42.1x4.8x1.5
Service Brake		Hydraulic Floor Pedal
Min Ground Clearance	In	4.3
Max traveling speed (load/unload)	Mph	10.6/11.8
Overall Height, forks raised	(in)	225
Battery	(V/A)	12/80
Engine		Mitsubishi 4EG
Engine Rated Power	HP/rp m	Diesel 49/2250
Service Weight	(lb.)	7716 lb.

The EKKO EK20D Diesel Forklift is designed to be used for all your material handling demands, warehousing, and distribution.

This unit is manufactured with high durable quality, Tier 4 EPA compliant with a Mitsubishi 4EG engine and competitive pricing.

- The operation space is enlarged and heightened overhead guard and using large arc shape of the overhead guard's front leg
- Multifunctional suspended seat increases the support of the driver, and reduce vibration, and balancing the weight of the driver.
- Steering wheel adjusting mechanism is disposed in the appropriate position making it easily adjustable.
- By using impedance composited muffler, this truck reduces the level of sound output.

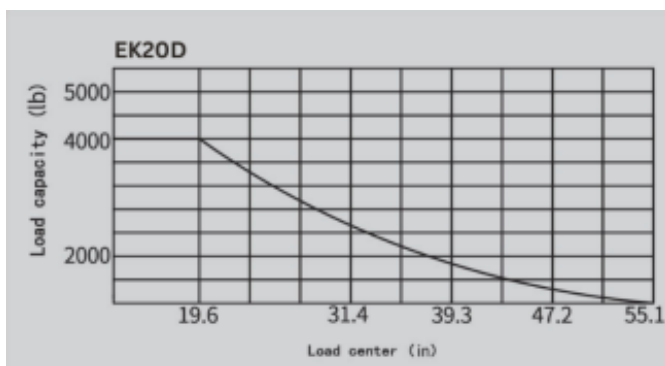

EK25D Diesel Forklift

Model		EK25D
Lift		Diesel
Drive		Sit-Down
Load capacity	(lb.)	5000
Load center distance	(in)	24
Wheelbase	(in)	62.9
Lifting height	(in)	185
Free lifting height	(in)	43.7
Lowered mast height	(in)	83
Mast/Fork carriage tilt forward/backward	(°)	3/6
Side Shift		Cascade
Overall length	(in)	144.6
Overall width	(in)	45.2
Tire Material	(in)	Solid Pneumatic Tire
Fork Size	(in)	42.1x4.8x1.5
Service Brake		Hydraulic Floor Pedal
Min Ground Clearance	In	4.3
Max traveling speed (load/unload)	Mph	10.6/11.8
Overall Height, forks raised	(in)	225
Battery	(V/A)	12/80
Engine		Mitsubishi 4EG
Engine Rated Power	HP/rp m	Diesel 49/2250
Service Weight	(lb.)	8465 lb.

The EKKO EK25D Diesel Forklift is designed to be used for all your material handling demands, warehousing, and distribution.

This unit is manufactured with high durable quality, Tier 4 EPA compliant with a Mitsubishi 4EG engine and competitive pricing.

- The operation space is enlarged and heightened overhead guard and using large arc shape of the overhead guard's front leg
- Multifunctional suspended seat increases the support of the driver, and reduce vibration, and balancing the weight of the driver.
- Steering wheel adjusting mechanism is disposed in the appropriate position making it easily adjustable.
- By using impedance composited muffler, this truck reduces the level of sound output.

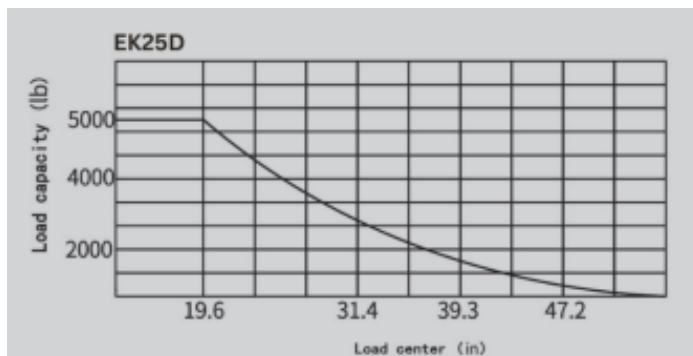

EK30D Diesel Forklift

Model		EK30D
Lift		Diesel
Drive		Sit-Down
Load capacity	(lb.)	6000
Load center distance	(in)	24
Wheelbase	(in)	66.9
Lifting height	(in)	185
Free lifting height	(in)	37.9
Lowered mast height	(in)	86.2
Mast/Fork carriage tilt forward/backward	(°)	3/6
Side Shift		Cascade
Overall length	(in)	151
Overall width	(in)	48.2
Tire Material	(in)	Solid Pneumatic Tire
Fork Size	(in)	42.1x4.8x1.5
Service Brake		Hydraulic Floor Pedal
Min Ground Clearance	In	4.7
Max traveling speed (load/unload)	Mph	11/12.1
Overall Height, forks raised	(in)	234
Battery	(V/A)	12/80
Engine		Mitsubishi 4EG
Engine Rated Power	HP/rp m	Diesel 49/2250
Service Weight	(lb.)	10,108 lb.

The EKKO EK30D Diesel Forklift is designed to be used for all your material handling demands, warehousing, and distribution.

This unit is manufactured with high durable quality, Tier 4 EPA compliant with a Mitsubishi 4EG engine and competitive pricing.

- The operation space is enlarged and heightened overhead guard and using large arc shape of the overhead guard's front leg
- Multifunctional suspended seat increases the support of the driver, and reduce vibration, and balancing the weight of the driver.
- Steering wheel adjusting mechanism is disposed in the appropriate position making it easily adjustable.
- By using impedance composited muffler, this truck reduces the level of sound output.

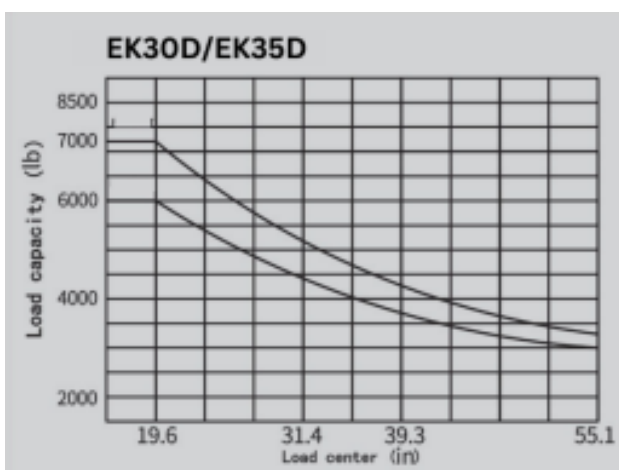

EK35D Diesel Forklift

Model		EK35D
Lift		DIESEL
Drive		Sit-Down
Load capacity	(lb.)	7000
Load center distance	(in)	24
Wheelbase	(in)	66.9
Lifting height	(in)	185
Free lifting height	(in)	37.9
Lowered mast height	(in)	86.2
Mast/Fork carriage tilt forward/backward	(°)	3/6
Side Shift		Cascade
Overall length	(in)	153
Overall width	(in)	50.5
Tire Material	(in)	Solid Pneumatic Tire
Fork Size	(in)	42.1x4.8x1.5
Service Brake		Hydraulic Floor Pedal
Min Ground Clearance	In	4.7
Max traveling speed (load/unload)	Mph	11/12.1
Overall Height, forks raised	(in)	234
Battery	(V/A)	12/80
Engine		Mitsubishi 4EG
Engine Rated Power	HP/rp m	Diesel 49/2250
Service Weight	(lb.)	10,967 lb.

The EKKO EK35D Diesel Forklift is designed to be used for all your material handling demands, warehousing, and distribution.

This unit is manufactured with high durable quality, Tier 4 EPA compliant with a Mitsubishi 4EG engine and competitive pricing.

- The operation space is enlarged and heightened overhead guard and using large arc shape of the overhead guard's front leg
- Multifunctional suspended seat increases the support of the driver, and reduce vibration, and balancing the weight of the driver.
- Steering wheel adjusting mechanism is disposed in the appropriate position making it easily adjustable.
- By using impedance composited muffler, this truck reduces the level of sound output.

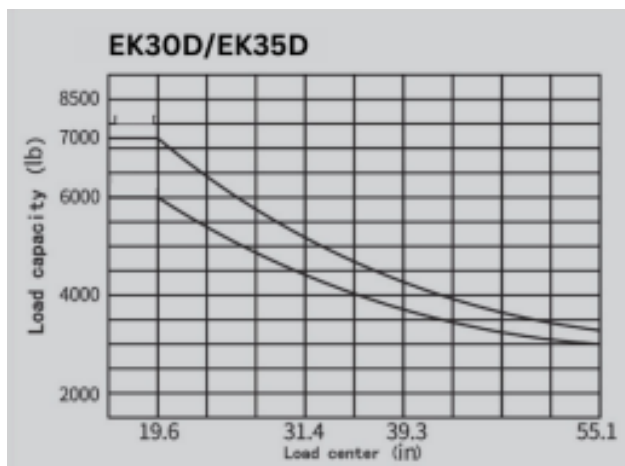

EK40D Diesel Forklift

Model		EK40D
Lift		Diesel
Drive		Sit-Down
Load capacity	(lb.)	8500
Load center distance	(in)	24
Wheelbase	(in)	70.8
Lifting height	(in)	185
Free lifting height	(in)	37.9
Lowered mast height	(in)	86.2
Mast/Fork carriage tilt forward/backward	(°)	3/6
Side Shift		Cascade
Overall length	(in)	157
Overall width	(in)	52.9
Tire Material	(in)	Solid Pneumatic Tire
Fork Size	(in)	42.1x4.8x1.5
Service Brake		Hydraulic Floor Pedal
Min Ground Clearance	In	4.7
Max traveling speed (load/unload)	Mph	10.3/11.2
Overall Height, forks raised	(in)	234
Battery	(V/A)	12/80
Engine		Mitsubishi 4EG
Engine Rated Power	HP/rp m	Diesel 49/2250
Service Weight	(lb.)	11,519 lb.

The EKKO EK40D Diesel Forklift is designed to be used for all your material handling demands, warehousing, and distribution. This unit is manufactured with high durable quality, Tier 4 EPA compliant with a Mitsubishi 4EG engine and competitive pricing.

- The operation space is enlarged and heightened overhead guard and using large arc shape of the overhead guard's front leg
- Multifunctional suspended seat increases the support of the driver, and reduce vibration, and balancing the weight of the driver.
- Steering wheel adjusting mechanism is disposed in the appropriate position making it easily adjustable.
- By using impedance composited muffler, this truck reduces the level of sound output.

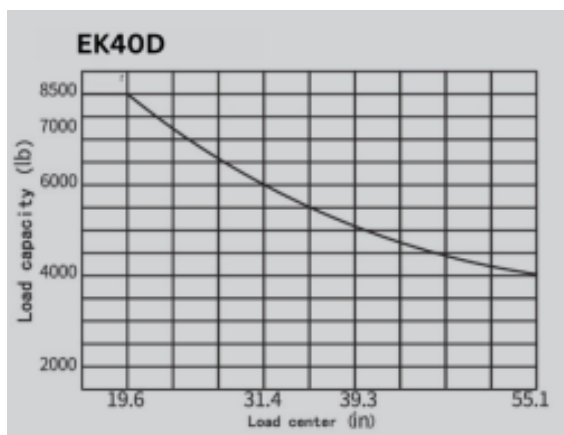

EK20TLP LPG Forklift

Model		EK20TLP
Lift		Propane
Drive		Sit-Down
Load capacity	(lb.)	4000
Load center distance	(in)	24
Wheelbase	(in)	62.9
Lifting height	(in)	185
Free lifting height	(in)	43.7
Lowered mast height	(in)	83
Mast/Fork carriage tilt forward/backward	(°)	3/6
Side Shift		Cascade
Overall length	(in)	141.8
Overall width	(in)	45.2
Tire Material	(in)	Solid Pneumatic Tire
Fork Size	(in)	42.1x4.8x1.5
Service Brake		Hydraulic Floor Pedal
Min Ground Clearance	In	4.3
Max traveling speed (load/unload)	Mph	10.6/11.8
Overall Height, forks raised	(in)	225
Battery	(V/A)	12/60
Engine		PSI 2.4
Engine Rated Power	HP/rp m	LPG: 63/2700
Service Weight	(lb.)	7716 lb.

The EKKO EK20TLP Liquid Propane 4 Wheel Forklift is designed to be used for all your material handling demands, warehousing, and distribution.

This unit is manufactured with high durable quality, Tier 4 EPA compliant with the PSI 2.4l engine and competitive pricing.

- The operation space is enlarged and heightened overhead guard and using large arc shape of the overhead guard's front leg
- Semi-suspension seat, and small steering wheel, electro-hydraulic direction changing, and automobile type double combined switch effectively improve driving comfort level.
- Cushion connection and whole suspension cab can absorb the vibrations of truck effectively.
- Small turning radius makes steering flexible and easy.
- with optimized hydraulic system, the truck is more energy-efficient and has lower fuel consumption.
- The engine satisfies the CARB 4 regulation

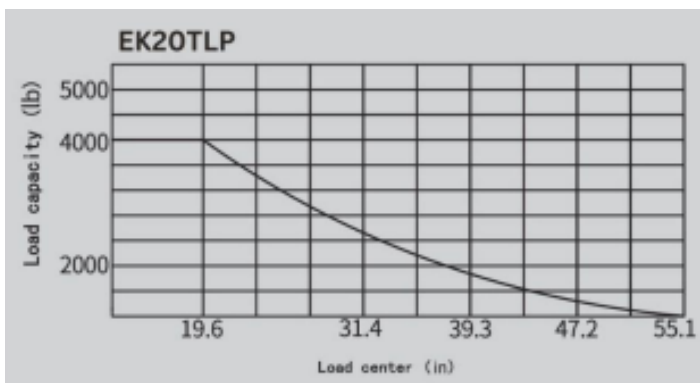

EK25TLP LPG Forklift

Model		EK25TLP
Lift		Propane
Drive		Sit-Down
Load capacity	(lb.)	5000
Load center distance	(in)	24
Wheelbase	(in)	62.9
Lifting height	(in)	185
Free lifting height	(in)	43.7
Lowered mast height	(in)	83
Mast/Fork carriage tilt forward/backward	(°)	3/6
Side Shift		Cascade
Overall length	(in)	144.6
Overall width	(in)	45.2
Tire Material	(in)	Solid Pneumatic Tire
Fork Size	(in)	42.1x4.8x1.5
Service Brake		Hydraulic Floor Pedal
Min Ground Clearance	In	4.3
Max traveling speed (load/unload)	Mph	10.6/11.8
Overall Height, forks raised	(in)	225
Battery	(V/A)	12/60
Engine		PSI 2.4
Engine Rated Power	HP/rp m	LPG: 63/2700
Service Weight	(lb.)	8465 lb.

The EKKO EK25TLP Liquid Propane 4 Wheel Forklift is designed to be used for all your material handling demands, warehousing, and distribution. This unit is manufactured with high durable quality, Tier 4 EPA compliant with the PSI 2.4l engine and competitive pricing.

- The operation space is enlarged and heightened overhead guard and using large arc shape of the overhead guard's front leg
- Semi-suspension seat, and small steering wheel, electro-hydraulic direction changing, and automobile type double combined switch effectively improve driving comfort level.
- Cushion connection and whole suspension cab can absorb the vibrations of truck effectively.
- Small turning radius makes steering flexible and easy.
- with optimized hydraulic system, the truck is more energy-efficient and has lower fuel consumption.
- The engine satisfies the CARB 4 regulation

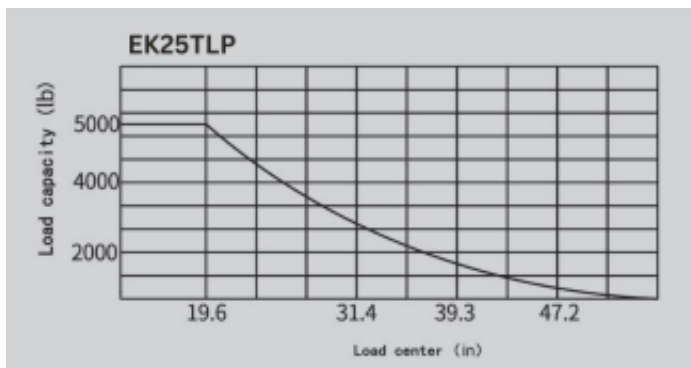

EK30TLP LPG Forklift

Model		EK30TLP
Lift		Propane
Drive		Sit-Down
Load capacity	(lb.)	6000
Load center distance	(in)	24
Wheelbase	(in)	66.9
Lifting height	(in)	185
Free lifting height	(in)	37.9
Lowered mast height	(in)	86.2
Mast/Fork carriage tilt forward/backward	(°)	3/6
Side Shift		Cascade
Overall length	(in)	151
Overall width	(in)	48.2
Tire Material	(in)	Solid Pneumatic Tire
Fork Size	(in)	42.1x4.8x1.5
Service Brake		Hydraulic Floor Pedal
Min Ground Clearance	In	4.7
Max traveling speed (load/unload)	Mph	11/12.1
Overall Height, forks raised	(in)	234
Battery	(V/A)	12/60
Engine		PSI 2.4
Engine Rated Power	HP/rp m	LPG: 63/2700
Service Weight	(lb.)	10,108 lb.

The EKKO EK30TLP Liquid Propane 4 Wheel Forklift is designed to be used for all your material handling demands, warehousing, and distribution. This unit is manufactured with high durable quality, Tier 4 EPA compliant with the PSI 2.4l engine and competitive pricing.

- The operation space is enlarged and heightened overhead guard and using large arc shape of the overhead guard's front leg
- Semi-suspension seat, and small steering wheel, electro-hydraulic direction changing, and automobile type double combined switch effectively improve driving comfort level.
- Cushion connection and whole suspension cab can absorb the vibrations of truck effectively.
- Small turning radius makes steering flexible and easy.
- with optimized hydraulic system, the truck is more energy-efficient and has lower fuel consumption.
- The engine satisfies the CARB 4 regulation

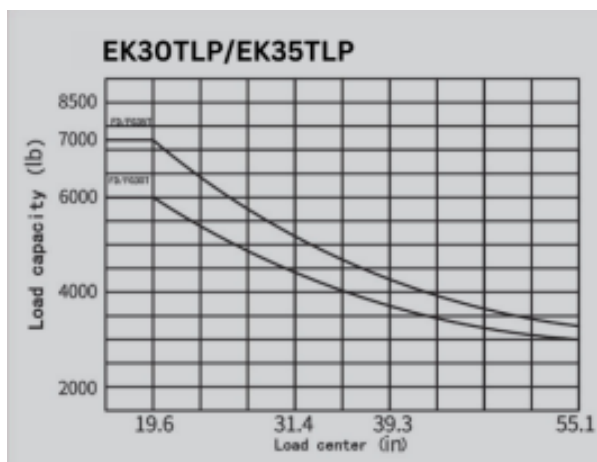

EK35TLP LPG Forklift

Model		EK35TLP
Lift		Propane
Drive		Sit-Down
Load capacity	(lb.)	7000
Load center distance	(in)	24
Wheelbase	(in)	66.9
Lifting height	(in)	185
Free lifting height	(in)	37.9
Lowered mast height	(in)	86.2
Mast/Fork carriage tilt forward/backward	(°)	3/6
Side Shift		Cascade
Overall length	(in)	153
Overall width	(in)	50.5
Tire Material	(in)	Solid Pneumatic Tire
Fork Size	(in)	42.1x4.8x1.5
Service Brake		Hydraulic Floor Pedal
Min Ground Clearance	In	4.7
Max traveling speed (load/unload)	Mph	11/12.1
Overall Height, forks raised	(in)	234
Battery	(V/A)	12/60
Engine		PSI 2.4
Engine Rated Power	HP/rp m	LPG: 63/2700
Service Weight	(lb.)	10,967 lb.

The EKKO EK35TLP Liquid Propane 4 Wheel Forklift is designed to be used for all your material handling demands, warehousing, and distribution. This unit is manufactured with high durable quality, Tier 4 EPA compliant with the PSI 2.4l engine and competitive pricing.

- The operation space is enlarged and heightened overhead guard and using large arc shape of the overhead guard's front leg
- Semi-suspension seat, and small steering wheel, electro-hydraulic direction changing, and automobile type double combined switch effectively improve driving comfort level.
- Cushion connection and whole suspension cab can absorb the vibrations of truck effectively.
- Small turning radius makes steering flexible and easy.
- with optimized hydraulic system, the truck is more energy-efficient and has lower fuel consumption.
- The engine satisfies the CARB 4 regulation

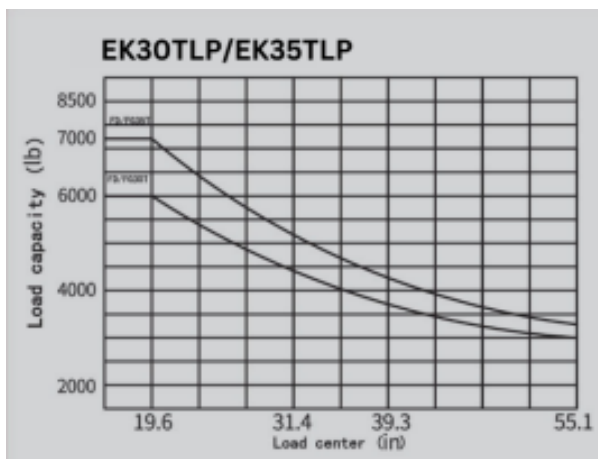

EK40TLP LPG Forklift

Model		EK40TLP
Lift		Propane
Drive		Sit-Down
Load capacity	(lb.)	8500
Load center distance	(in)	24
Wheelbase	(in)	70.8
Lifting height	(in)	185
Free lifting height	(in)	37.9
Lowered mast height	(in)	86.2
Mast/Fork carriage tilt forward/backward	(°)	3/6
Side Shift		Cascade
Overall length	(in)	157
Overall width	(in)	52.9
Tire Material	(in)	Solid Pneumatic Tire
Fork Size	(in)	42.1x4.8x1.5
Service Brake		Hydraulic Floor Pedal
Min Ground Clearance	In	4.7
Max traveling speed (load/unload)	Mph	10.3/11.2
Overall Height, forks raised	(in)	234
Battery	(V/A)	12/60
Engine		PSI 2.4
Engine Rated Power	HP/rp m	LPG: 63/2700
Service Weight	(lb.)	11,519 lb.

The EKKO EK40TLP Liquid Propane 4 Wheel Forklift is designed to be used for all your material handling demands, warehousing, and distribution. This unit is manufactured with high durable quality, Tier 4 EPA compliant with the PSI 2.4l engine and competitive pricing.

- The operation space is enlarged and heightened overhead guard and using large arc shape of the overhead guard's front leg
- Semi-suspension seat, and small steering wheel, electro-hydraulic direction changing, and automobile type double combined switch effectively improve driving comfort level.
- Cushion connection and whole suspension cab can absorb the vibrations of truck effectively.
- Small turning radius makes steering flexible and easy.
- with optimized hydraulic system, the truck is more energy-efficient and has lower fuel consumption.
- The engine satisfies the CARB 4 regulation

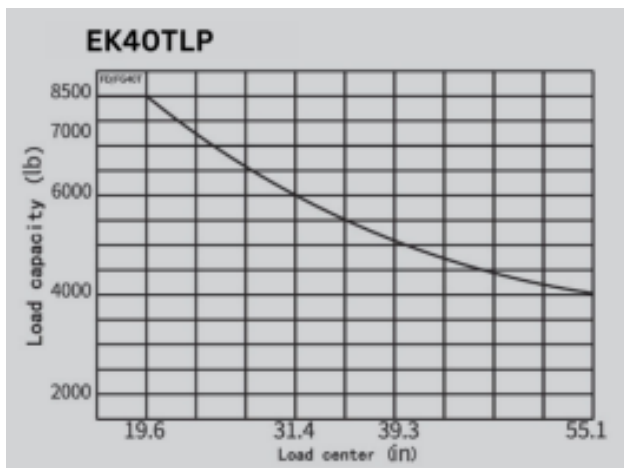

EK25LP LPG Forklift

Model		EK25LP
Lift		Propane
Drive		Sit-Down
Load capacity	(lb.)	5000
Load center distance	(in)	24
Wheelbase	(in)	65
Lifting height	(in)	189
Free lifting height	(in)	47.64
Lowered mast height	(in)	87
Mast/Fork carriage tilt forward/backward	(°)	3/6
Side Shift		3-way valve
Overall length	(in)	143.9
Overall width	(in)	45.3
Tire Material	(in)	Solid Pneumatic Tire
Fork Size	(in)	42.1x4.8x1.5
Service Brake		Hydraulic Floor Pedal
Min Ground Clearance	In	4.53
Max traveling speed (load/unload)	Mph	11.2/11.8
Backrest Height (from surface of the forks)	(in)	39.37
Battery	(V/A)	12/80
Engine		Kubota WG2503
Engine Rated Power	HP/rp m	LPG: 58.3/2600
Service Weight	(lb.)	8910 lb.

The EKKO EK25LP Liquid Propane 4 Wheel Forklift is designed to be used for all your material handling demands, warehousing, and distribution.

This unit is manufactured with high durable quality, Tier 4 EPA compliant with the Kubota engine and competitive pricing.

- Multifunction instrument panel - motoring for Safety and efficient operation
- Operator compartment- nonslip entrance step, wider access & leg room.
- Adjustable steering column limiting operator arm and shoulder fatigue.
- Excellent Operator visibility.
- Integral Heavy-Duty Chassis- ensuring driver protection
- Steer axle pivots to 80 degrees for tighter turning radius.
- Hydraulic controls

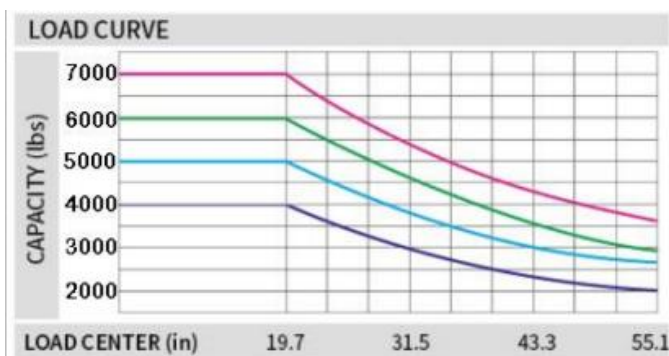

EK25-212LP LPG Forklift

Model		EK25-212LP
Lift		Propane
Drive		Sit-Down
Load capacity	(lb.)	5000
Load center distance	(in)	24
Wheelbase	(in)	65
Lifting height	(in)	212
Free lifting height	(in)	55.1
Lowered mast height	(in)	94.5
Mast/Fork carriage tilt forward/backward	(°)	3/6
Side Shift		3-way valve
Overall length	(in)	143.9
Overall width	(in)	45.3
Tire Material	(Solid Pneumatic Tire
Fork Size	(in)	42.1x4.8x1.5
Service Brake		Hydraulic Floor Pedal
Min Ground Clearance	In	4.53
Max traveling speed (load/unload)	Mph	11.2/11.8
Backrest Height (from surface of the forks)	(in)	39.37
Battery	(V/A)	12/80
Engine		Kubota WG2503
Engine Rated Power	HP/rp m	LPG: 58.3/2600
Service Weight	(lb.)	9120 lb.

The EKKO EK25-212LP Liquid Propane 4 Wheel Forklift is designed to be used for all your material handling demands, warehousing, and distribution.

This unit is manufactured with high durable quality, Tier 4 EPA compliant with the Kubota engine and competitive pricing.

- Multifunction instrument panel - motoring for Safety and efficient operation
- Operator compartment- nonslip entrance step, wider access & leg room.
- Adjustable steering column limiting operator arm and shoulder fatigue.
- Excellent Operator visibility.
- Integral Heavy-Duty Chassis- ensuring driver protection
- Steer axle pivots to 80 degrees for tighter turning radius.
- Hydraulic controls

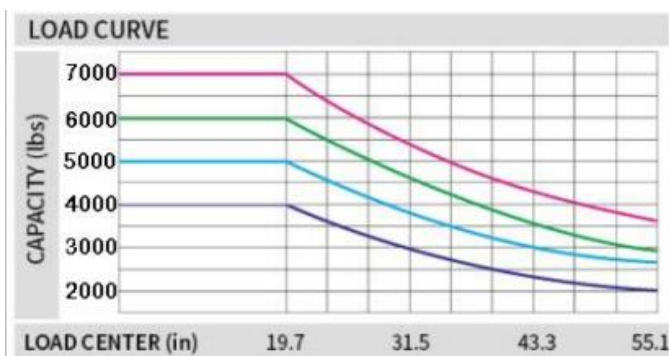

EK25CLP LPG Forklift

Model		EK25CLP
Lift		Propane
Drive		Sit-Down
Load capacity	(lb.)	5000
Load center distance	(in)	24
Wheelbase	(in)	58
Lifting height	(in)	189
Free lifting height	(in)	44
Lowered mast height	(in)	85
Mast/Fork carriage tilt forward/backward	(°)	3/6
Side Shift		3-way valve
Overall length	(in)	136.8
Overall width	(in)	42
Tire Material		Smooth Cushion Tires
Fork Size	(in)	42.1x4.8x1.5
Service Brake		Hydraulic Floor Pedal
Min Ground Clearance	In	3.5
Max traveling speed (load/unload)	Mph	10.8/10.8
Backrest Height (from surface of the forks)	(in)	40
Battery	(V/A)	12/60
Engine		Mitsubishi 4G64 (PSI Engine)
Engine Rated Power	HP/rp m	LPG: 63/2700
Service Weight	(lb.)	9370 lb.

The EKKO EK25CLP Liquid Propane 4 Wheel Forklift is designed to be used for all your material handling demands, warehousing, and distribution.

This unit is manufactured with high durable quality, Tier 4 EPA compliant with the Mitsubishi engine and competitive pricing.

- Multifunction instrument panel - motoring for Safety and efficient operation
- Operator compartment- nonslip entrance step, wider access & leg room.
- Adjustable steering column limiting operator arm and shoulder fatigue.
- Excellent Operator visibility.
- Integral Heavy-Duty Chassis- ensuring driver protection
- Steer axle pivots to 80 degrees for tighter turning radius.
- Hydraulic controls

The EK25CLP Features smooth Cushion Tires that are perfect for use indoors on a smooth flat surface



EK25SLP LPG Forklift

Model		EK25SLP
Lift		Propane
Drive		Sit-Down
Load capacity	(lb.)	5000
Load center distance	(in)	24
Wheelbase	(in)	58
Lifting height	(in)	189
Free lifting height	(in)	44
Lowered mast height	(in)	85
Mast/Fork carriage tilt forward/backward	(°)	3/6
Side Shift		3-way valve
Overall length	(in)	136.8
Overall width	(in)	42
Tire Material		Pattern Cushion Tires
Fork Size	(in)	42.1x4.8x1.5
Service Brake		Hydraulic Floor Pedal
Min Ground Clearance	In	3.5
Max traveling speed (load/unload)	Mph	10.8/10.8
Backrest Height (from surface of the forks)	(in)	40
Battery	(V/A)	12/60
Engine		Mitsubishi 4G64 (PSI Engine)
Engine Rated Power	HP/rp m	LPG: 63/2700
Service Weight	(lb.)	9370 lb.

The EKKO EK25SLP Liquid Propane 4 Wheel Forklift is designed to be used for all your material handling demands, warehousing, and distribution.

This unit is manufactured with high durable quality, Tier 4 EPA compliant with the Mitsubishi engine and competitive pricing.

- Multifunction instrument panel - motoring for Safety and efficient operation
- Operator compartment- nonslip entrance step, wider access & leg room.
- Adjustable steering column limiting operator arm and shoulder fatigue.
- Excellent Operator visibility.
- Integral Heavy-Duty Chassis- ensuring driver protection
- Steer axle pivots to 80 degrees for tighter turning radius.
- Hydraulic controls

The EK25SLP Features Pattern Cushion Tires to help prevent slipping on slick flooring.



EK30SLP LPG Forklift

Model		EK30SLP
Lift		Propane
Drive		Sit-Down
Load capacity	(lb.)	6000
Load center distance	(in)	24
Wheelbase	(in)	58
Lifting height	(in)	189
Free lifting height	(in)	44
Lowered mast height	(in)	88
Mast/Fork carriage tilt forward/backward	(°)	3/6
Side Shift		3-way valve
Overall length	(in)	140
Overall width	(in)	44
Tire Material		Pattern Cushion Tires
Fork Size	(in)	42.1x4.8x1.5
Service Brake		Hydraulic Floor Pedal
Min Ground Clearance	In	3.5
Max traveling speed (load/unload)	Mph	10.8/10.8
Backrest Height (from surface of the forks)	(in)	48
Battery	(V/A)	12/60
Engine		Mitsubishi 4G64 (PSI Engine)
Engine Rated Power	HP/rp m	LPG: 64/2700
Service Weight	(lb.)	10785 lb.

The EKKO EK30SLP Liquid Propane 4 Wheel Forklift is designed to be used for all your material handling demands, warehousing, and distribution.

This unit is manufactured with high durable quality, Tier 4 EPA compliant with the Mitsubishi engine and competitive pricing.

- Multifunction instrument panel - motoring for Safety and efficient operation
- Operator compartment- nonslip entrance step, wider access & leg room.
- Adjustable steering column limiting operator arm and shoulder fatigue.
- Excellent Operator visibility.
- Integral Heavy-Duty Chassis- ensuring driver protection
- Steer axle pivots to 80 degrees for tighter turning radius.
- Hydraulic controls

The EK30SLP Features Pattern Cushion Tires to help prevent slipping on slick flooring.



EK30LP LPG Forklift

Model		EK30LP
Lift		Propane
Drive		Sit-Down
Load capacity	(lb.)	6000
Load center distance	(in)	24
Wheelbase	(in)	69
Lifting height	(in)	189
Free lifting height	(in)	40.9
Lowered mast height	(in)	89.4
Mast/Fork carriage tilt forward/backward	(°)	3/6
Side Shift		3-way valve
Overall length	(in)	150.3
Overall width	(in)	48.2
Tire Material		Solid Pneumatic Tires
Fork Size	(in)	42.1x4.92x1.77
Service Brake		Hydraulic Floor Pedal
Min Ground Clearance	In	4.53
Max traveling speed (load/unload)	Mph	11.8/11.8
Backrest Height (from surface of the forks)	(in)	46.54
Battery	(V/A)	12/80
Engine		Kubota WG2503
Engine Rated Power	HP/rp m	LPG: 58.3/2600
Service Weight	(lb.)	10320 lb.

The EKKO EK30LP Liquid Propane 4 Wheel Forklift is designed to be used for all your material handling demands, warehousing, and distribution.

This unit is manufactured with high durable quality, Tier 4 EPA compliant with the Kubota engine and competitive pricing.

- Multifunction instrument panel - motoring for Safety and efficient operation
- Operator compartment- nonslip entrance step, wider access & leg room.
- Adjustable steering column limiting operator arm and shoulder fatigue.
- Excellent Operator visibility.
- Integral Heavy-Duty Chassis- ensuring driver protection
- Steer axle pivots to 80 degrees for tighter turning radius.
- Hydraulic controls

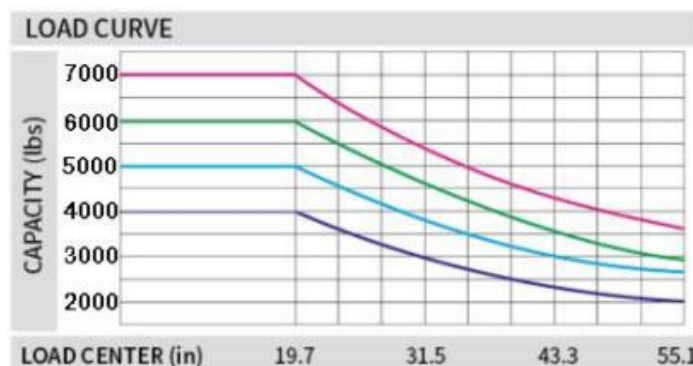

EK35LP LPG Forklift

Model		EK35LP
Lift		Propane
Drive		Sit-Down
Load capacity	(lb.)	7000
Load center distance	(in)	24
Wheelbase	(in)	68.9
Lifting height	(in)	189
Free lifting height	(in)	42.9
Lowered mast height	(in)	89.4
Mast/Fork carriage tilt forward/backward	(°)	3/6
Side Shift		3-way valve
Overall length	(in)	150.4
Overall width	(in)	48.2
Tire Material		Solid Pneumatic Tires
Fork Size	(in)	42.1x4.9x1.97
Service Brake		Hydraulic Floor Pedal
Min Ground Clearance	In	5.3
Max traveling speed (load/unload)	Mph	11.8/11.8
Backrest Height (from surface of the forks)	(in)	46.3
Battery	(V/A)	12/80
Engine		Kubota WG2503
Engine Rated Power	HP/rp m	LPG: 60.1/2400
Service Weight	(lb.)	10605 lb.

The EKKO EK35LP Liquid Propane 4 Wheel Forklift is designed to be used for all your material handling demands, warehousing, and distribution.

This unit is manufactured with high durable quality, Tier 4 EPA compliant with the Kubota engine and competitive pricing.

- Multifunction instrument panel - motoring for Safety and efficient operation
- Operator compartment- nonslip entrance step, wider access & leg room.
- Adjustable steering column limiting operator arm and shoulder fatigue.
- Excellent Operator visibility.
- Integral Heavy-Duty Chassis- ensuring driver protection
- Steer axle pivots to 80 degrees for tighter turning radius.
- Hydraulic controls

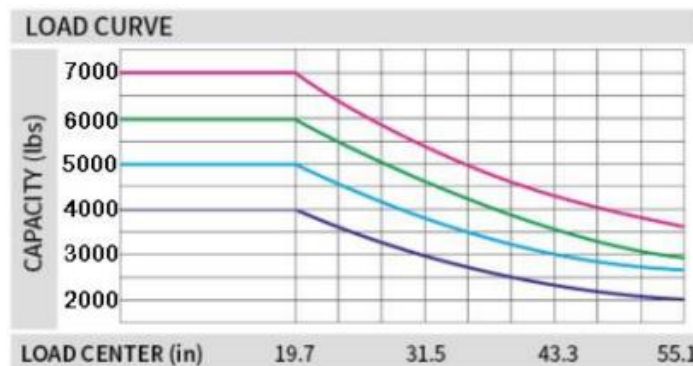

EK50LP LPG Forklift

Model		EK50LP
Lift		Propane
Drive		Sit-Down
Load capacity	(lb.)	10,000
Load center distance	(in)	24
Wheelbase	(in)	61.8
Lifting height	(in)	185
Free lifting height	(in)	44.3
Lowered mast height	(in)	91.9
Mast/Fork carriage tilt forward/backward	(°)	3/6
Side Shift		3-way valve
Overall length	(in)	157
Overall width	(in)	55.9
Tire Material		Pattern Cushion Tire
Fork Size	(in)	48x5.9x1.97
Service Brake		Hydraulic Foot Pedal
Min Ground Clearance	In	4.3
Max traveling speed (load/unload)	Mph	10.5/11.2
Backrest Height (from surface of the forks)	(in)	47.6
Parking Brake		Hand Lever
Engine		Kubota WG3800
Engine Rated Power	HP/rp m	LPG: 63.2
Service Weight	(lb.)	16,250 lb.

The EKKO EK50LP Liquid Propane 4 Wheel Forklift is designed to be used for all your material handling demands, warehousing, and distribution.

This unit is manufactured with high durable quality, Tier 4 EPA compliant with the Kubota engine and competitive pricing.

- Multifunction instrument panel - motoring for Safety and efficient operation
- Operator compartment- nonslip entrance step, wider access & leg room.
- Adjustable steering column limiting operator arm and shoulder fatigue.
- Excellent Operator visibility.
- Integral Heavy-Duty Chassis- ensuring driver protection
- Steer axle pivots to 80 degrees for tighter turning radius.
- Hydraulic controls

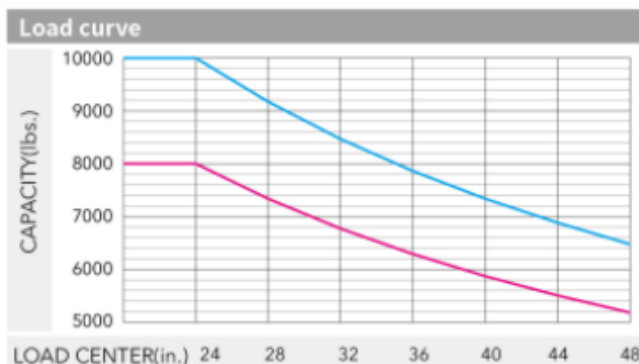

EK20GS Electric Forklift

Model		EK20GS
Lift		Electric
Drive		Sit-Down
Load capacity	(lb.)	4500
Load center distance	(in)	20
Wheelbase	(in)	65.4
Lifting height	(in)	189
Free lifting height	(in)	47.48
Lowered mast height	(in)	79
Mast/Fork carriage tilt forward/backward	(°)	6/6
Side Shift		3-way valve
Overall length	(in)	133
Overall width	(in)	46.45
Fork size,	(in)	42
Min Ground Clearance	(in)	3.95
Turning radius	(in)	85
Traveling Speed (laden/unladen)	MPH	9/9.3
Lift speed, laden/unladen	(in/s)	17.3/11.4
Service Brake		Hydraulic Foot Pedal
Charger	(3 PHASE 480V
Battery voltage	(V/Ah)	48V/600Ah Lead Acid
Service Weight	(lb.)	9232 lb.

The EKKO EK20GS 4 Wheel Electric Forklift is designed for use for all your material handling demands. It is ideal for loading and unloading trucks, loading docks, stock rooms, manufacturing floors and warehousing.

Made from high quality steel and components with durable quality drives to withstand any terrain, usage, impact and directional changes for the use of any application with confidence and assurance.

- Load Capacity 4500 lb.
- Raised Height 189" (15.75ft)
- Side Shift
- Solid Pneumatic Tires
- ZAPI Controller
- Battery 48/600 AH Lead acid
- 3-Phase 480V Charger (optional 220V)

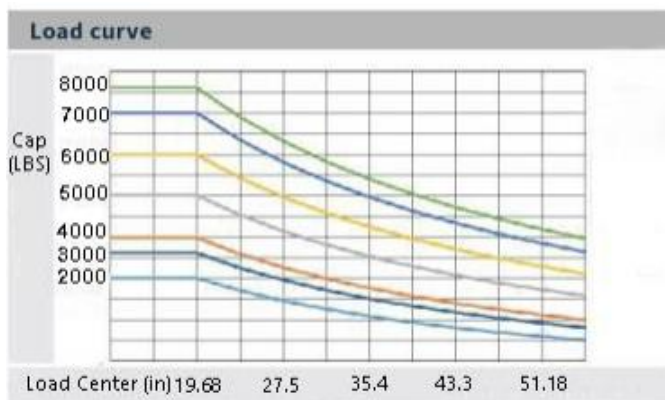

20

EK25GB Electric Forklift

Model		EK25GB
Lift		Electric
Drive		Sit-Down
Load capacity	(lb.)	5000
Load center distance	(in)	24
Wheelbase	(in)	65.35
Lifting height	(in)	189
Free lifting height	(in)	47.48
Lowered mast height	(in)	83
Mast/Fork carriage tilt forward/backward	(°)	6/6
Side Shift		3-way valve
Overall length	(in)	137.95
Overall width	(in)	46.45
Fork size, (thick/width/length)	(in)	1.57/4.72/42.12
Min Ground Clearance	(in)	3.95
Turning radius	(in)	84.2
Traveling Speed (laden/unladen)	MPH	9/9.3
Lift speed, laden/unladen	(in/s)	17.3/11.4
Service Brake		Hydraulic Foot Pedal
Charger	(3 PHASE 480V
Battery voltage	(V/Ah)	48V/600Ah Lead Acid
Service Weight	(lb.)	9981 lb.

The EKKO EK25GB 4 Wheel Electric Forklift is designed for use for all your material handling demands. It is ideal for loading and unloading trucks, loading docks, stock rooms, manufacturing floors and warehousing.

Made from high quality steel and components with durable quality drives to withstand any terrain, usage, impact and directional changes for the use of any application with confidence and assurance.

- Load Capacity 5000 lb.
- Raised Height 189" (15.75ft)
- Side Shift
- Solid Pneumatic Tires
- ZAPI Controller
- Battery 48/600 AH Lead acid
- 3-Phase 480V Charger (optional 220V)

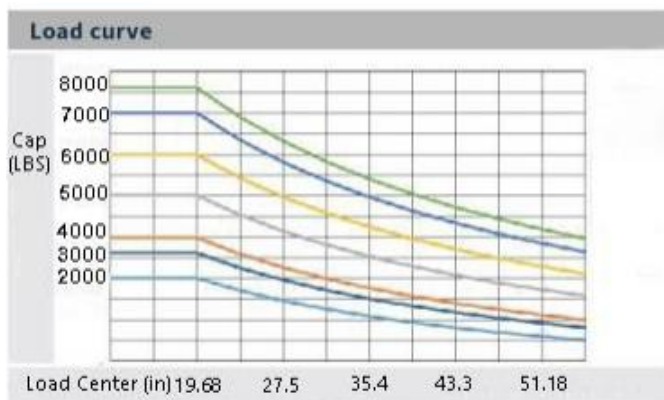

EK25GHB Electric Forklift

Model		EK25GHB
Lift		Electric
Drive		Sit-Down
Load capacity	(lb.)	5000
Load center distance	(in)	24
Wheelbase	(in)	65.35
Lifting height	(in)	212
Free lifting height	(in)	54.9
Lowered mast height	(in)	94.5
Mast/Fork carriage tilt forward/backward	(°)	6/6
Side Shift		3-way valve
Overall length	(in)	137.95
Overall width	(in)	46.45
Fork size, (thick/width/length)	(in)	1.57/4.72/42.12
Min Ground Clearance	(in)	3.95
Turning radius	(in)	84.2
Traveling Speed (laden/unladen)	MPH	9/9.3
Max gradient performance Laden/Unladen	(%)	15/25
Service Brake		Hydraulic Foot Pedal
Charger	(3 PHASE 480V
Battery voltage	(V/Ah)	48V/600Ah Lead Acid
Service Weight	(lb.)	10114 lb.

The EKKO EK25GHB 4 Wheel Electric Forklift is designed for use for all your material handling demands. It is ideal for loading and unloading trucks, loading docks, stock rooms, manufacturing floors and warehousing.

Made from high quality steel and components with durable quality drives to withstand any terrain, usage, impact and directional changes for the use of any application with confidence and assurance.

- Load Capacity 5000 lb.
- Raised Height 212" (17.67ft)
- Side Shift
- Solid Pneumatic Tires
- ZAPI Controller
- Battery 48/600 AH Lead acid
- 3-Phase 480V Charger (optional 220V)

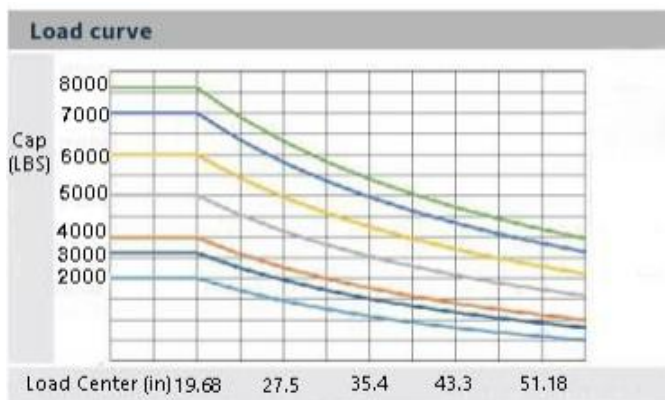

EK30GB Electric Forklift

Model		EK30GB
Lift		Electric
Drive		Sit-Down
Load capacity	(lb.)	6000
Load center distance	(in)	24
Wheelbase	(in)	68.9
Lifting height	(in)	189
Free lifting height	(in)	40.94
Lowered mast height	(in)	83
Mast/Fork carriage tilt forward/backward	(°)	6/6
Side Shift		3-way valve
Overall length	(in)	135.3
Overall width	(in)	49.6
Fork size, (thick/width/length)	(in)	1.57/4.72/42.12
Fork Adjust Width	(in)	8.7-29
Turning radius	(in)	87.9
Driving Motor	(K/W)	15
Max gradient performance Laden/Unladen	(%)	17/26
Service Brake		Hydraulic Foot Pedal
Charger	(3 PHASE 480V
Battery voltage	(V/Ah)	48V/600Ah Lead Acid
Service Weight	(lb.)	10795 lb.

The EKKO EK30GB 4 Wheel Electric Forklift is designed for use for all your material handling demands. It is ideal for loading and unloading trucks, loading docks, stock rooms, manufacturing floors and warehousing.

Made from high quality steel and components with durable quality drives to withstand any terrain, usage, impact and directional changes for the use of any application with confidence and assurance.

- Load Capacity 6000 lb.
- Raised Height 189" (15.75ft)
- Side Shift
- Solid Pneumatic Tires
- ZAPI Controller
- Battery 48/600 AH Lead acid
- 3-Phase 480V Charger (optional 220V)

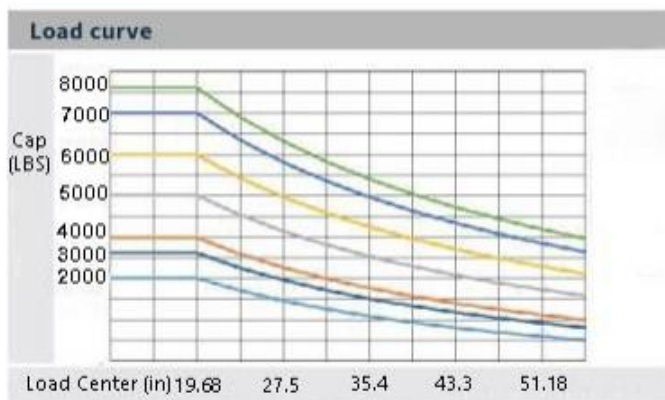

EK35GB Electric Forklift

Model		EK35GB
Lift		Electric
Drive		Sit-Down
Load capacity	(lb.)	7000
Load center distance	(in)	24
Wheelbase	(in)	68.9
Lifting height	(in)	189
Free lifting height	(in)	40.94
Lowered mast height	(in)	83
Mast/Fork carriage tilt forward/backward	(°)	6/6
Side Shift		3-way valve
Overall length	(in)	136.3
Overall width	(in)	49.6
Fork size, (thick/width/length)	(in)	1.57/4.72/42.12
Fork Adjust Width	(in)	8.7-29
Turning radius	(in)	87.9
Driving Motor	(K/W)	15
Max gradient performance Laden/Unladen	(%)	15/23
Service Brake		Hydraulic Foot Pedal
Charger	(3 PHASE 480V
Battery voltage	(V/Ah)	48V/600Ah Lead Acid
Service Weight	(lb.)	11408 lb.

The EKKO EK35GB 4 Wheel Electric Forklift is designed for use for all your material handling demands. It is ideal for loading and unloading trucks, loading docks, stock rooms, manufacturing floors and warehousing.

Made from high quality steel and components with durable quality drives to withstand any terrain, usage, impact and directional changes for the use of any application with confidence and assurance.

- Load Capacity 7000 lb.
- Raised Height 189" (15.75ft)
- Side Shift
- Solid Pneumatic Tires
- ZAPI Controller
- Battery 48/600 AH Lead acid
- 3-Phase 480V Charger (optional 220V)

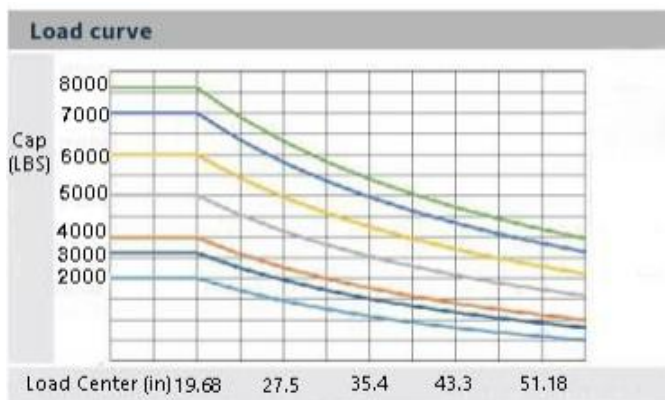

EK15A 3 Wheel Electric Forklift

Model		EK15A
Lift		Electric
Drive		Electric
Load capacity	(lb.)	3300
Load center distance	(in)	24
Wheelbase	(in)	43
Lifting height	(in)	177
Free lifting height	(in)	59
Lowered mast height	(in)	79.6
Mast/Fork carriage tilt forward/backward	(°)	2/5
Side Shift		3-way valve
Overall length	(in)	106.6
Overall width	(in)	36
Fork size, Thick/Width/Length	(in)	1.4/4/45.3
Fork adjust width	(in)	8.7-29
Turning radius	(in)	53
Max gradient performance, laden/unladen	(%)	6/8
Lift speed, laden/unladen	(in/s)	4/5.5
Lowering speed, laden/unladen	(in/s)	5.3/4.7
Charger	(V/A)	24V/50A
Driving Motor	(V/W)	AC 24V/2000W
Lifting Motor	(V/W)	24V/2500W
Battery voltage	(V/Ah)	24V/400Ah (Side)
Service Weight	(lb.)	5665

The EKKO EK15A 3 Wheel Electric Forklift is designed for use for small aisles, limited spaces and budget. It is ideal for loading and unloading trucks, loading docks, stock rooms, manufacturing floors and warehousing.

Made from high quality steel and components with durable quality drives to withstand any terrain, usage, impact and directional changes for the use of any application with confidence and assurance.

- Load Capacity 3300 Lbs.
- Raised Height 177" (14.75ft)
- Side Shift
- Free Lift 59"
- EPS (Electric Power Steering)
- 24V AC Drive Motor
- Solid Wheels
- Battery 24V/400AH
- Charger 24V/50A

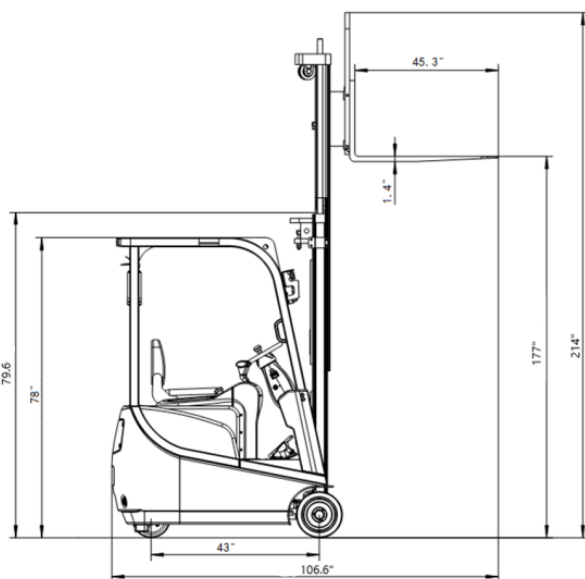

EK13A 3 Wheel Electric Forklift

Model		EK13A
Lift		Electric
Drive		Electric
Load capacity	(lb.)	3300
Load center distance	(in)	24
Wheelbase	(in)	43
Lifting height	(in)	138
Free lifting height	(in)	4
Lowered mast height	(in)	88.4
Mast/Fork carriage tilt forward/backward	(°)	2/5
Side Shift		3-way valve
Overall length	(in)	105
Overall width	(in)	36
Fork size, Thick/Width/Length	(in)	1.4/4/45.3
Fork adjust width	(in)	8.7-29
Turning radius	(in)	53
Max gradient performance, laden/unladen	(%)	6/8
Lift speed, laden/unladen	(in/s)	4/5.5
Lowering speed, laden/unladen	(in/s)	5.3/4.7
Charger	(V/A)	24V/50A
Driving Motor	(V/W)	AC 24V/2000W
Lifting Motor	(V/W)	24V/2500W
Battery voltage	(V/Ah)	24V/350Ah (Side)
Service Weight	(lb.)	5200

The EKKO EK13A 3 Wheel Electric Forklift is designed for use for small aisles, limited spaces and budget. It is ideal for loading and unloading trucks, loading docks, stock rooms, manufacturing floors and warehousing.

Made from high quality steel and components with durable quality drives to withstand any terrain, usage, impact and directional changes for the use of any application with confidence and assurance.

- Load Capacity 3300 Lbs.
- Raised Height 138” (11.5ft)
- Side Shift
- Free Lift 4”
- EPS (Electric Power Steering)
- 24V AC Drive Motor
- Solid Wheels
- Battery 24V/400AH
- Charger 24V/50A

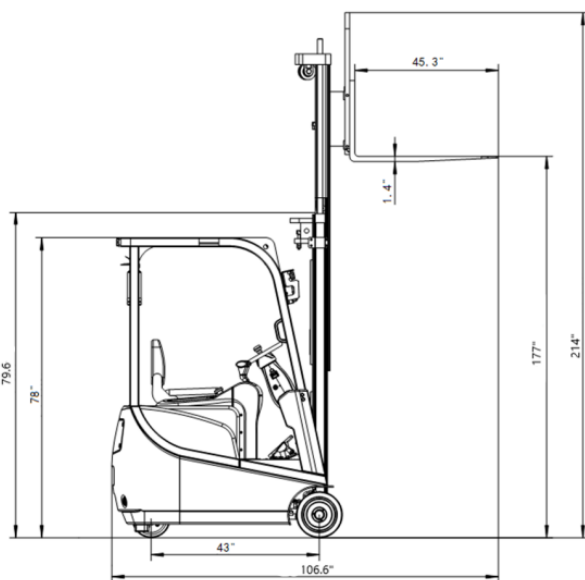

EK20GT-LI Lithium Powered Forklift

Model		EK20GT-LI
Lift		Electric
Drive		Electric
Load capacity	(lb.)	4000
Load center distance	(in)	24
Wheelbase	(in)	63.7
Lifting height	(in)	185
Free lifting height	(in)	43.7
Lowered mast height	(in)	83
Mast/Fork carriage tilt forward/backward	(°)	6/6
Side Shift		Cascade
Overall length	(in)	138.9
Overall width	(in)	45.2
Fork size, Length	(in)	42.1
Min. Outside Turning Radius	(in)	86.2
Travel Speed (laden/unladen)	(mph)	9.3/9.3
Ground clearance at mast	(in)	4.3
Service Brake		Hydraulic foot Pedal
Controller		INMOTION
Charger	(V/A)	3 phase 480V
Battery, Lithium	(V/A)	115v/125Ah
Service Weight	(lb.)	7594

The EKKO EK20GT-LI 4 Wheel Electric Forklift is designed for use for all your material handling demands. It is ideal for loading and unloading trucks, loading docks, stock rooms, manufacturing floors and warehousing.

Made from high quality steel and components with durable quality drives to withstand any terrain, usage, impact and directional changes for the use of any application with confidence and assurance.

- Load Capacity 4000 Lbs.
- Raised Height 185” (15.4ft)
- Side Shift
- Free Lift 43.7”
- EPS (Electric Power Steering)
- Solid Pneumatic Tires
- Battery 115V/125Ah
- Charger 3-Phase 480V (optional 220V & 110V)



EK25GT-LI Lithium Powered Forklift

Model		EK25GT-LI
Lift		Electric
Drive		Electric
Load capacity	(lb.)	5000
Load center distance	(in)	24
Wheelbase	(in)	63.7
Lifting height	(in)	185
Free lifting height	(in)	43.7
Lowered mast height	(in)	83
Mast/Fork carriage tilt forward/backward	(°)	6/6
Side Shift		Cascade
Overall length	(in)	141
Overall width	(in)	45.2
Fork size, Length	(in)	42.1
Min. Outside Turning Radius	(in)	88.9
Travel Speed (laden/unladen)	(mph)	9.3/9.3
Ground clearance at mast	(in)	4.3
Service Brake		Hydraulic foot Pedal
Controller		INMOTION
Charger	(V/A)	3 phase 480V
Battery, Lithium	(V/A)	115v/125Ah
Service Weight	(lb.)	8344

The EKKO EK25GT-LI 4 Wheel Electric Forklift is designed for use for all your material handling demands. It is ideal for loading and unloading trucks, loading docks, stock rooms, manufacturing floors and warehousing.

Made from high quality steel and components with durable quality drives to withstand any terrain, usage, impact and directional changes for the use of any application with confidence and assurance.

- Load Capacity 5000 Lbs.
- Raised Height 185” (15.4ft)
- Side Shift
- Free Lift 43.7”
- EPS (Electric Power Steering)
- Solid Pneumatic Tires
- Battery 115V/125Ah
- Charger 3-Phase 480V (optional 220V & 110V)



EK30GT-LI Lithium Powered Forklift

Model		EK30GT-LI
Lift		Electric
Drive		Electric
Load capacity	(lb.)	6000
Load center distance	(in)	24
Wheelbase	(in)	66.9
Lifting height	(in)	185
Free lifting height	(in)	37.9
Lowered mast height	(in)	86.2
Mast/Fork carriage tilt forward/backward	(°)	6/6
Side Shift		Cascade
Overall length	(in)	148
Overall width	(in)	48.2
Fork size, Length	(in)	42.1
Min. Outside Turning Radius	(in)	96.2
Travel Speed (laden/unladen)	(mph)	9.3/9.3
Ground clearance at mast	(in)	4.7
Service Brake		Hydraulic foot Pedal
Controller		INMOTION
Charger	(V/A)	3 phase 480V
Battery, Lithium	(V/A)	115v/173Ah
Service Weight	(lb.)	9788

The EKKO EK30GT-LI 4 Wheel Electric Forklift is designed for use for all your material handling demands. It is ideal for loading and unloading trucks, loading docks, stock rooms, manufacturing floors and warehousing.

Made from high quality steel and components with durable quality drives to withstand any terrain, usage, impact and directional changes for the use of any application with confidence and assurance.

- Load Capacity 6000 Lbs.
- Raised Height 185” (15.4ft)
- Side Shift
- Free Lift 37.9”
- EPS (Electric Power Steering)
- Solid Pneumatic Tires
- Battery 115V/173Ah
- Charger 3-Phase 480V (optional 220V & 110V)



EK35GT-LI Lithium Powered Forklift

Model		EK35GT-LI
Lift		Electric
Drive		Electric
Load capacity	(lb.)	7000
Load center distance	(in)	24
Wheelbase	(in)	66.9
Lifting height	(in)	185
Free lifting height	(in)	37.9
Lowered mast height	(in)	86.2
Mast/Fork carriage tilt forward/backward	(°)	6/6
Side Shift		Cascade
Overall length	(in)	150
Overall width	(in)	50.5
Fork size, Length	(in)	42.1
Min. Outside Turning Radius	(in)	98.2
Travel Speed (laden/unladen)	(mph)	9.3/9.3
Ground clearance at mast	(in)	4.7
Service Brake		Hydraulic foot Pedal
Controller		INMOTION
Charger	(V/A)	3 phase 480V
Battery, Lithium	(V/A)	115V/173Ah
Service Weight	(lb.)	10648

The EKKO EK35GT-LI 4 Wheel Electric Forklift is designed for use for all your material handling demands. It is ideal for loading and unloading trucks, loading docks, stock rooms, manufacturing floors and warehousing.

Made from high quality steel and components with durable quality drives to withstand any terrain, usage, impact and directional changes for the use of any application with confidence and assurance.

- Load Capacity 7000 Lbs.
- Raised Height 185” (15.4ft)
- Side Shift
- Free Lift 37.9”
- EPS (Electric Power Steering)
- Solid Pneumatic Tires
- Battery 115V/173Ah
- Charger 3-Phase 480V (optional 220V & 110V)



EK40GT-LI Lithium Powered Forklift

Model		EK40GT-LI
Lift		Electric
Drive		Electric
Load capacity	(lb.)	8500
Load center distance	(in)	24
Wheelbase	(in)	70.8
Lifting height	(in)	185
Free lifting height	(in)	37.9
Lowered mast height	(in)	86.2
Mast/Fork carriage tilt forward/backward	(°)	6/6
Side Shift		Cascade
Overall length	(in)	154
Overall width	(in)	53.7
Fork size, Length	(in)	42.1
Min. Outside Turning Radius	(in)	99.6
Travel Speed (laden/unladen)	(mph)	9.3/9.3
Ground clearance at mast	(in)	4.7
Service Brake		Hydraulic foot Pedal
Controller		INMOTION
Charger	(V/A)	3 phase 480V
Battery, Lithium	(V/A)	115V/173Ah
Service Weight	(lb.)	11364

The EKKO EK40GT-LI 4 Wheel Electric Forklift is designed for use for all your material handling demands. It is ideal for loading and unloading trucks, loading docks, stock rooms, manufacturing floors and warehousing.

Made from high quality steel and components with durable quality drives to withstand any terrain, usage, impact and directional changes for the use of any application with confidence and assurance.

- Load Capacity 8500 Lbs.
- Raised Height 185” (15.4ft)
- Side Shift
- Free Lift 37.9”
- EPS (Electric Power Steering)
- Solid Pneumatic Tires
- Battery 115V/173Ah
- Charger 3-Phase 480V (optional 220V & 110V)



EK20G-LI Lithium Powered Forklift

Model		EK20G-LI
Lift		Electric
Drive		Electric
Load capacity	(lb.)	4500
Load center distance	(in)	24
Wheelbase	(in)	65.4
Lifting height	(in)	189
Free lifting height	(in)	47.8
Lowered mast height	(in)	79
Mast/Fork carriage tilt forward/backward	(°)	6/6
Side Shift		3-way valve
Overall length	(in)	133
Overall width	(in)	46.47
Fork size, Length	(in)	42
Min. Outside Turning Radius	(in)	85
Travel Speed (laden/unladen)	(mph)	9/9.3
Ground clearance at mast	(in)	3.95
Service Brake		Hydraulic foot Pedal
Controller		ZAPI
Charger	(V/A)	3 phase 480V
Battery, Lithium	(V/A)	80V/202Ah
Service Weight	(lb.)	9032

The EKKO EK20G-LI 4 Wheel Electric Forklift is designed for use for all your material handling demands. It is ideal for loading and unloading trucks, loading docks, stock rooms, manufacturing floors and warehousing.

Made from high quality steel and components with durable quality drives to withstand any terrain, usage, impact and directional changes for the use of any application with confidence and assurance.

- Load Capacity 4500 Lbs.
- Raised Height 189” (15.75ft)
- Side Shift
- Free Lift 47.48”
- ZAPI Controller
- Solid Pneumatic Tires
- Battery 80V/202Ah Lithium
- Charger 3-Phase 480V (optional 220V & 110V)

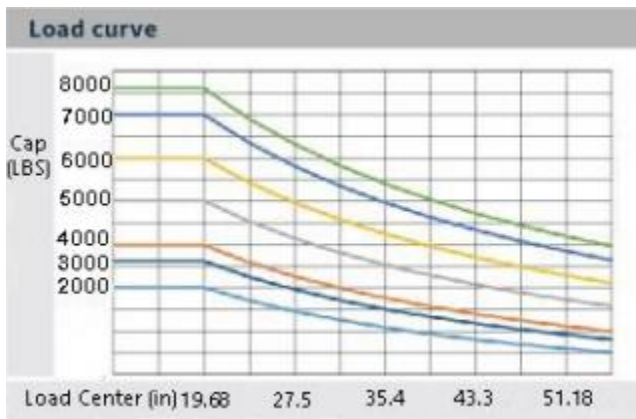

EK25G-LI Lithium Powered Forklift

Model		EK25G-LI
Lift		Electric
Drive		Electric
Load capacity	(lb.)	5000
Load center distance	(in)	24
Wheelbase	(in)	65.35
Lifting height	(in)	189
Free lifting height	(in)	47.48
Lowered mast height	(in)	83
Mast/Fork carriage tilt forward/backward	(°)	6/6
Side Shift		3-way valve
Overall length	(in)	137.95
Overall width	(in)	46.45
Fork size, Length	(in)	42
Min. Outside Turning Radius	(in)	84.2
Max Gradient Performance (laden/unladen)	(%)	15/25
Ground clearance at mast	(in)	3.95
Service Brake		Hydraulic foot Pedal
Controller		ZAPI
Charger	(V/A)	3 phase 480V
Battery, Lithium	(V/A)	80V/202Ah
Service Weight	(lb.)	9782

The EKKO EK25G-LI 4 Wheel Electric Forklift is designed for use for all your material handling demands. It is ideal for loading and unloading trucks, loading docks, stock rooms, manufacturing floors and warehousing.

Made from high quality steel and components with durable quality drives to withstand any terrain, usage, impact and directional changes for the use of any application with confidence and assurance.

- Load Capacity 5000 Lbs.
- Raised Height 189” (15.75ft)
- Side Shift
- Free Lift 47.48”
- ZAPI Controller
- Solid Pneumatic Tires
- Battery 80V/202Ah Lithium
- Charger 3-Phase 480V (optional 220V & 110V)

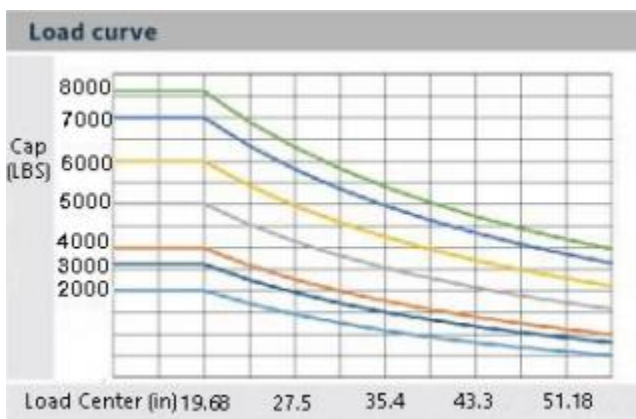

EK25G-212LI Lithium Powered Forklift

Model		EK25G-LI
Lift		Electric
Drive		Electric
Load capacity	(lb.)	5000
Load center distance	(in)	24
Wheelbase	(in)	65.35
Lifting height	(in)	212
Free lifting height	(in)	54.9
Lowered mast height	(in)	94.5
Mast/Fork carriage tilt forward/backward	(°)	6/6
Side Shift		3-way valve
Overall length	(in)	138
Overall width	(in)	46.45
Fork size, Length	(in)	42
Min. Outside Turning Radius	(in)	84.2
Max Gradient Performance (laden/unladen)	(%)	15/25
Ground clearance at mast	(in)	3.95
Service Brake		Hydraulic foot Pedal
Controller		ZAPI
Charger	(V/A)	3 phase 480V
Battery, Lithium	(V/A)	80V/202Ah
Service Weight	(lb.)	9915

The EKKO EK25G-212LI 4 Wheel Electric Forklift is designed for use for all your material handling demands. It is ideal for loading and unloading trucks, loading docks, stock rooms, manufacturing floors and warehousing.

Made from high quality steel and components with durable quality drives to withstand any terrain, usage, impact and directional changes for the use of any application with confidence and assurance.

- Load Capacity 5000 Lbs.
- Raised Height 212” (17.67ft)
- Side Shift
- Free Lift 54.9”
- ZAPI Controller
- Solid Pneumatic Tires
- Battery 80V/202Ah Lithium
- Charger 3-Phase 480V (optional 220V & 110V)

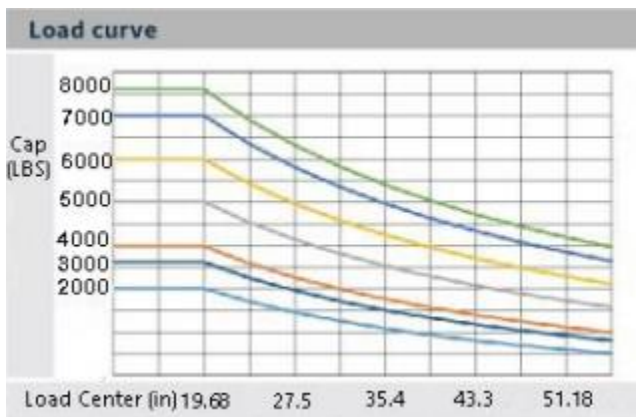

EK30G-LI Lithium Powered Forklift

Model		EK30G-LI
Lift		Electric
Drive		Electric
Load capacity	(lb.)	6000
Load center distance	(in)	24
Wheelbase	(in)	68.9
Lifting height	(in)	189
Free lifting height	(in)	40.94
Lowered mast height	(in)	83
Mast/Fork carriage tilt forward/backward	(°)	6/6
Side Shift		3-way valve
Overall length	(in)	143.2
Overall width	(in)	49.6
Fork size, Length	(in)	42
Min. Outside Turning Radius	(in)	87.9
Max Gradient Performance (laden/unladen)	(%)	17/26
Ground clearance at mast	(in)	4.33
Service Brake		Hydraulic foot Pedal
Controller		ZAPI
Charger	(V/A)	3 phase 480V
Battery, Lithium	(V/A)	80V/250Ah
Service Weight	(lb.)	10596

The EKKO EK30G-LI 4 Wheel Electric Forklift is designed for use for all your material handling demands. It is ideal for loading and unloading trucks, loading docks, stock rooms, manufacturing floors and warehousing.

Made from high quality steel and components with durable quality drives to withstand any terrain, usage, impact and directional changes for the use of any application with confidence and assurance.

- Load Capacity 6000 Lbs.
- Raised Height 189” (15.75ft)
- Side Shift
- Free Lift 40.94”
- ZAPI Controller
- Solid Pneumatic Tires
- Battery 80V/250Ah Lithium
- Charger 3-Phase 480V (optional 220V & 110V)

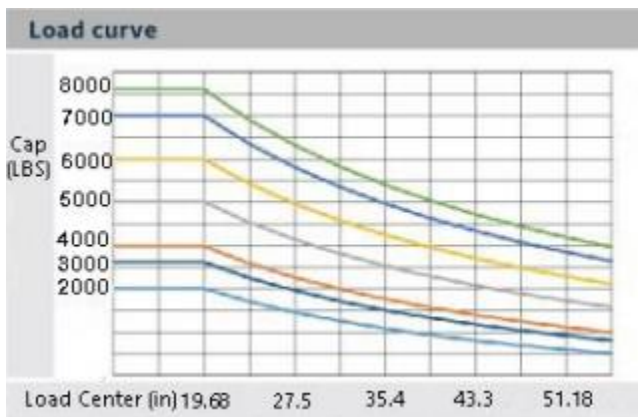

EK35G-LI Lithium Powered Forklift

Model		EK35G-LI
Lift		Electric
Drive		Electric
Load capacity	(lb.)	7000
Load center distance	(in)	24
Wheelbase	(in)	68.9
Lifting height	(in)	189
Free lifting height	(in)	40.94
Lowered mast height	(in)	83
Mast/Fork carriage tilt forward/backward	(°)	6/6
Side Shift		3-way valve
Overall length	(in)	143.4
Overall width	(in)	49.6
Fork size, Length	(in)	42
Min. Outside Turning Radius	(in)	87.9
Max Gradient Performance (laden/unladen)	(%)	15/23
Ground clearance at mast	(in)	4.33
Service Brake		Hydraulic foot Pedal
Controller		ZAPI
Charger	(V/A)	3 phase 480V
Battery, Lithium	(V/A)	80V/250Ah
Service Weight	(lb.)	11208

The EKKO EK35G-LI 4 Wheel Electric Forklift is designed for use for all your material handling demands. It is ideal for loading and unloading trucks, loading docks, stock rooms, manufacturing floors and warehousing.

Made from high quality steel and components with durable quality drives to withstand any terrain, usage, impact and directional changes for the use of any application with confidence and assurance.

- Load Capacity 7000 Lbs.
- Raised Height 189” (15.75ft)
- Side Shift
- Free Lift 40.94”
- ZAPI Controller
- Solid Pneumatic Tires
- Battery 80V/250Ah Lithium
- Charger 3-Phase 480V (optional 220V & 110V)

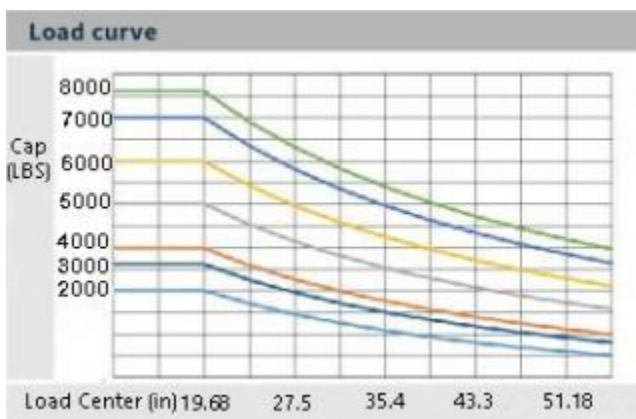

EK18A-189LI Lithium Powered Forklift

Model		EK18A-189LI
Lift		Electric
Drive		Electric
Load capacity	(lb.)	4000
Load center distance	(in)	24
Wheelbase	(in)	55.1
Lifting height	(in)	189
Free lifting height	(in)	46.5
Lowered mast height	(in)	86.2
Mast/Fork carriage tilt forward/backward	(°)	3/5
Side Shift		3-way valve
Overall length	(in)	116.9
Overall width	(in)	44.1
Fork size, Length	(in)	42
Min. Outside Turning Radius	(in)	65.9
Max Gradient Performance (laden/unladen)	(%)	22/30
Ground clearance at mast	(in)	3.5
Service Brake		Hydraulic foot Pedal
Controller		ZAPI
Charger	(V/A)	3 phase 480V
Battery, Lithium	(V/A)	80V/202Ah
Service Weight	(lb.)	7341

The EKKO EK18A-189LI 3 Wheel Electric Forklift is designed for use for all your material handling demands. It is ideal for loading and unloading trucks, loading docks, stock rooms, manufacturing floors and warehousing.

Made from high quality steel and components with durable quality drives to withstand any terrain, usage, impact and directional changes for the use of any application with confidence and assurance.

- Load Capacity 4000 Lbs.
- Raised Height 189” (15.75ft)
- Side Shift
- Free Lift 46.5”
- ZAPI Controller
- Solid Pneumatic Tires
- Battery 80V/202Ah Lithium
- Charger 3-Phase 480V (optional 220V & 110V)

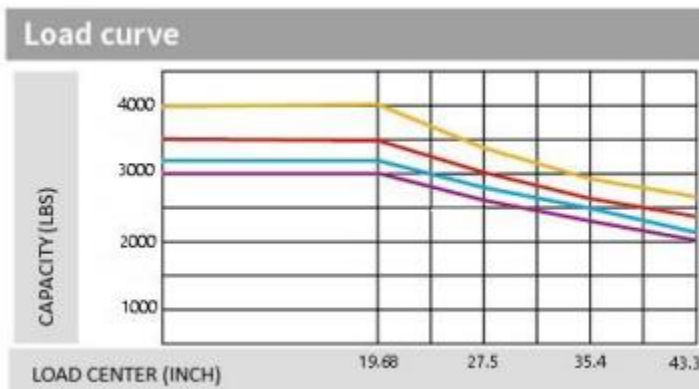

EK18A-212LI Lithium Powered Forklift

Model		EK18A-212LI
Lift		Electric
Drive		Electric
Load capacity	(lb.)	4000
Load center distance	(in)	24
Wheelbase	(in)	55.1
Lifting height	(in)	212
Free lifting height	(in)	55.7
Lowered mast height	(in)	95.5
Mast/Fork carriage tilt forward/backward	(°)	3/5
Side Shift		3-way valve
Overall length	(in)	116.9
Overall width	(in)	44.1
Fork size, Length	(in)	42
Min. Outside Turning Radius	(in)	65.9
Max Gradient Performance (laden/unladen)	(%)	22/30
Ground clearance at mast	(in)	3.5
Service Brake		Hydraulic foot Pedal
Controller		ZAPI
Charger	(V/A)	3 phase 480V
Battery, Lithium	(V/A)	80V/202Ah
Service Weight	(lb.)	8105

The EKKO EK18A-212LI 3 Wheel Electric Forklift is designed for use for all your material handling demands. It is ideal for loading and unloading trucks, loading docks, stock rooms, manufacturing floors and warehousing.

Made from high quality steel and components with durable quality drives to withstand any terrain, usage, impact and directional changes for the use of any application with confidence and assurance.

- Load Capacity 4000 Lbs.
- Raised Height 212” (17.67ft)
- Side Shift
- Free Lift 55.7”
- ZAPI Controller
- Solid Pneumatic Tires
- Battery 80V/202Ah Lithium
- Charger 3-Phase 480V (optional 220V & 110V)

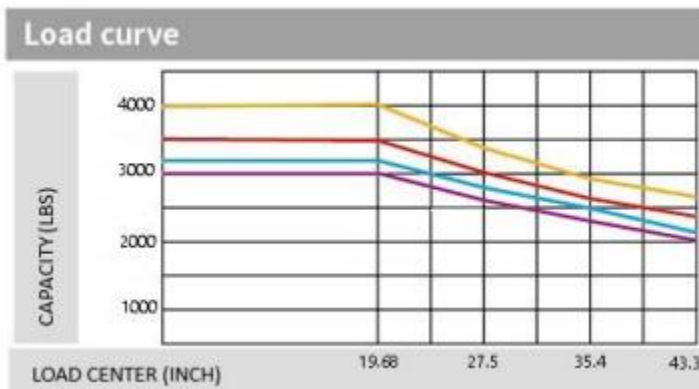

EK15A-189LI Lithium Powered Forklift

Model		EK15A-189LI
Lift		Electric
Drive		Electric
Load capacity	(lb.)	3300
Load center distance	(in)	23.6
Wheelbase	(in)	42.91
Lifting height	(in)	189
Free lifting height	(in)	62.56
Lowered mast height	(in)	83.54
Mast/Fork carriage tilt forward/backward	(°)	2/5
Side Shift		3-way valve
Overall length	(in)	111.1
Overall width	(in)	36.1
Fork size, Length	(in)	42
Min. Outside Turning Radius	(in)	53.07
Max Gradient Performance (laden/unladen)	(%)	6/10
Ground clearance at mast	(in)	3.54
Service Brake		Hydraulic foot Pedal
Controller		Curtis
Charger	(V/A)	24V/50A
Battery, Lithium	(V/A)	24V/350Ah
Service Weight	(lb.)	5560

The EKKO EK15A-189LI 3 Wheel Electric Forklift is designed for use for all your material handling demands. It is ideal for loading and unloading trucks, loading docks, stock rooms, manufacturing floors and warehousing.

Made from high quality steel and components with durable quality drives to withstand any terrain, usage, impact and directional changes for the use of any application with confidence and assurance.

- Load Capacity 3300 Lbs.
- Raised Height 189” (15.75ft)
- Side Shift
- Free Lift 62.56”
- Curtis Controller
- Rubber Tires
- Battery 24V/350Ah Lithium
- Charger Single Phase 24V/50A

